



## ÅRSREGNSKAPET FOR REGNSKAPSÅRET 2022 - GENERELL INFORMASJON

### Enheten

Organisasjonsnummer:	996 755 193
Organisasjonsform:	Aksjeselskap
Foretaksnavn:	TRAFO HOLDING AS
Forretningsadresse:	Elektroveien 7 3300 HOKKSUND

### Regnskapsår

Årsregnskapets periode:	01.04.2021 - 31.03.2022
-------------------------	-------------------------

### Konsern

Mørselskap i konsern:	Ja
Konsernregnskap lagt ved:	Ja

### Regnskapsregler

Regler for små foretak benyttet:	Nei
Benyttet ved utarbeidelsen av årsregnskapet til selskapet:	Regnskapslovens alminnelige regler
Benyttet ved utarbeidelsen av årsregnskapet til konsernet:	-

### Årsregnskapet fastsatt av kompetent organ

Bekreftet av representant for selskapet:	Simon Mark Gibbins
Dato for fastsettelse av årsregnskapet:	05.07.2022

### Grunnlag for avgivelse

År 2022: Årsregnskapet er elektronisk innlevert
År 2021: Tall er hentet fra elektronisk innlevert årsregnskap fra 2022

*Det er ikke krav til at årsregnskapet m.v. som sendes til Regnskapsregisteret er undertegnet. Kontrollen på at dette er utført ligger hos revisor/enhetens øverste organ. Sikkerheten ivaretas ved at innsender har rolle/rettighet for innsending av årsregnskapet via Altinn, og ved at det bekreftes at årsregnskapet er fastsatt av kompetent organ.*

Brønnøysundregistrene, 25.07.2023



## Resultatregnskap

Beløp i: NOK	Note	2022	2021
<b>RESULTATREGNSKAP</b>			
<b>Kostnader</b>			
Lønnskostnad	1		
Annen driftskostnad	1	58 685	44 929
<b>Sum kostnader</b>		<b>58 685</b>	<b>44 929</b>
<b>Driftsresultat</b>		<b>-58 685</b>	<b>-44 929</b>
<b>Finansinntekter og finanskostnader</b>			
Inntekt på investering i datterselskap	6	115 000 000	17 599 021
Renteinntekt fra foretak i samme konsern	6		
Annen renteinntekt		171 607	137 899
<b>Sum finansinntekter</b>		<b>115 171 607</b>	<b>17 736 920</b>
Rentekostnad til foretak i samme konsern	6	3 373 333	3 224 450
<b>Sum finanskostnader</b>		<b>3 373 333</b>	<b>3 224 450</b>
<b>Netto finans</b>		<b>111 798 274</b>	<b>14 512 470</b>
<b>Ordinært resultat før skattekostnad</b>		<b>111 739 589</b>	<b>14 467 540</b>
Skattekostnad på ordinært resultat	2	2 582 710	3 182 859
<b>Ordinært resultat etter skattekostnad</b>		<b>109 156 879</b>	<b>11 284 681</b>
<b>Årsresultat</b>	5	<b>109 156 879</b>	<b>11 284 681</b>
<b>Årsresultat etter minoritetsinteresser</b>		<b>109 156 879</b>	<b>11 284 681</b>
<b>Totalresultat</b>		<b>109 156 879</b>	<b>11 284 681</b>
<b>Overføringer og disponeringer</b>			
Ordinært utbytte		72 500 000	100 000 000
Overført fra annen egenkapital		36 656 879	-88 715 319
<b>Sum overføringer og disponeringer</b>		<b>109 156 879</b>	<b>11 284 681</b>



## Balanse

Beløp i: NOK	Note	2022	2021
<b>BALANSE - EIENDELER</b>			
<b>Anleggsmidler</b>			
<b>Immaterielle eiendeler</b>			
Utsatt skattefordel	2		87 364
<b>Sum immaterielle eiendeler</b>			<b>87 364</b>
<b>Finansielle anleggsmidler</b>			
Investering i datterselskap	3	353 692 501	353 692 501
Investering i annet foretak i samme konsern	3		
Lån til foretak i samme konsern	6		
<b>Sum finansielle anleggsmidler</b>		<b>353 692 501</b>	<b>353 692 501</b>
<b>Sum anleggsmidler</b>		<b>353 692 501</b>	<b>353 779 865</b>
<b>Omløpsmidler</b>			
<b>Varer</b>			
<b>Fordringer</b>			
Andre kortsiktige fordringer		15 001 250	17 747 341
<b>Sum fordringer</b>		<b>15 001 250</b>	<b>17 747 341</b>
<b>Investeringer</b>			
Aksjer og andeler i foretak i samme konsern	3		
<b>Bankinnskudd, kontanter og lignende</b>			
Bankinnskudd, kontanter o.l.		51 420 506	17 892 629
<b>Sum bankinnskudd, kontanter og lignende</b>		<b>51 420 506</b>	<b>17 892 629</b>
<b>Sum omløpsmidler</b>		<b>66 421 756</b>	<b>35 639 970</b>
<b>SUM EIENDELER</b>		<b>420 114 257</b>	<b>389 419 835</b>

## BALANSE - EGENKAPITAL OG GJELD

### Egenkapital



## Balanse

Beløp i: NOK	Note	2022	2021
<b>Innskutt egenkapital</b>			
Aksjekapital	4	215 545 458	215 545 458
Beholdning av egne aksjer	4	-11 908	-11 908
Overkurs		72 513 835	72 513 835
<b>Sum innskutt egenkapital</b>		<b>288 047 385</b>	<b>288 047 385</b>
<b>Opptjent egenkapital</b>			
Annen egenkapital		36 656 879	
<b>Sum opptjent egenkapital</b>		<b>36 656 879</b>	
<b>Sum egenkapital</b>	5	<b>324 704 264</b>	<b>288 047 385</b>
<b>Gjeld</b>			
<b>Langsiktig gjeld</b>			
Utsatt skatt	2		
<b>Annen langsiktig gjeld</b>			
Langsiktig konserngjeld	6	90 000 000	98 453 025
<b>Sum annen langsiktig gjeld</b>		<b>90 000 000</b>	<b>98 453 025</b>
<b>Sum langsiktig gjeld</b>		<b>90 000 000</b>	<b>98 453 025</b>
<b>Kortsiktig gjeld</b>			
Leverandørgjeld		6 250	
Betalbar skatt	2	5 379 833	2 896 425
Annen kortsiktig gjeld		23 910	23 000
<b>Sum kortsiktig gjeld</b>		<b>5 409 993</b>	<b>2 919 425</b>
<b>Sum gjeld</b>		<b>95 409 993</b>	<b>101 372 450</b>
<b>SUM EGENKAPITAL OG GJELD</b>		<b>420 114 257</b>	<b>389 419 835</b>

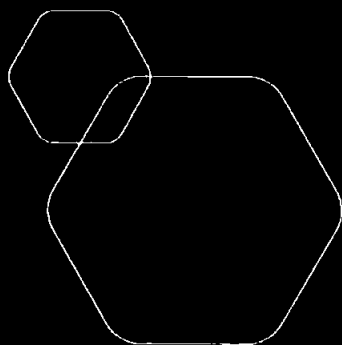

# Årsregnskap 2021/ 2022

## Trafo Holding AS

Styrets årsberetning  
Resultatregnskap  
Balanse  
Kontantstrøm  
Noter til regnskapet

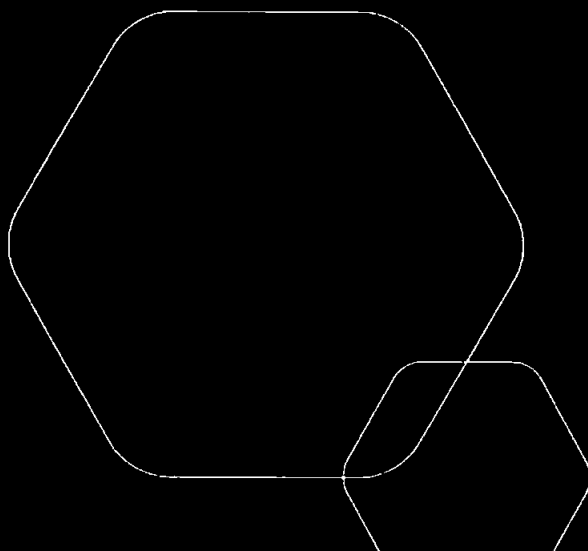

Org.nr.: 996 755 193



## Årsberetning 2021/2022 for Trafo Holding AS

### Virksomhetens art og hvordan den drives:

Trafo Holding AS er morselskap for Noratel Gruppen. Noratel Gruppen er leverandør av transformatorer, DC-strømforsyninger og andre viklede komponenter fra egen produksjon og fra samarbeidspartnere. Hovedmarkedet er i Europa, men salget foregår til kunder i hele verden. Gruppen har produksjon i Norge, Sverige, Finland, Polen, Nord Amerika, Sri Lanka, Kina og India. Selskapet er 100 % eid av DiscoverIE Nordic Holdings Ltd og inngår i DiscoverIE konsernet som er notert på London børsen. Trafo Holding AS avlegger ikke konsernregnskap, men det henvises til konsernregnskapet for DiscoverIE for mer detaljert informasjon om konsernet.

Selskapets virksomhet er lokalisert i Hokksund. Det henvises til årsberetningene for datterselskapene og morselskapet for mer detaljerte opplysninger om hvert enkelt selskap og konsernet. Regnskapsåret omfatter perioden fra 1. april 2021 til 31. mars 2022.

### FORTSATT DRIFT:

Forutsetningen om fortsatt drift er til stede, og årsregnskapet for 2021/2022 er satt opp under denne forutsetning. Selskapet vil fremover videreføre samme aktiviteter som tidligere.

### ARBEIDSMILJØ:

Trafo Holding AS har ingen ansatte. Selskapene i konsernet fører oversikt over sykefravær blant de ansatte. Det er i konsernet ikke registrert alvorlige skader i løpet av året. Konsernet har som mål å være en arbeidsplass der det er full likestilling mellom kvinner og menn. Alle ansettelsesvilkår og muligheter for øvrig er uavhengig av kjønn.

### DISKRIMINERING:

Selskapet har gjennom datterselskapene virksomhet i mange land der forskjellige nasjonaliteter, språk, religion og livssyn er representert. Selskapet søker å behandle alle likeverdig og forhindre diskriminering og sikre like muligheter for alle. Styret er ikke kjent med diskriminerende forhold i virksomheten. Det er derfor ikke gjennomført eller iverksatt særskilte tiltak for å fremme formålet i diskrimineringsloven.

### FORSIKRINGSDEKNING

Det er tegnet ansvarsforsikring for styret i selskapet. Forsikringen omfatter formuestap som styret påfører selskapet.

### YTRE MILJØ:

Virksomheten i konsernet har ingen nevneverdige utslipp til luft, vann eller grunn. Virksomheten produserer ikke spesialavfall. Metallavfall fra produksjonen blir levert til gjenvinning hos avfallsforretning. Emballasjeavfall og brennbart/nedbrytbart produksjonsavfall som ikke gjenbrukes/gjenvinnes leveres på godkjent avfallsplass. Det norske selskapet i konsernet er medlem av RENAS AS og Materialretur AS.

### FORSKNINGS- OG UTVIKLINGSAKTIVITETER:

Konsernet har ikke hatt vesentlige kostnader til forsknings- og utviklingsaktiviteter i 2021/2022

### ØKONOMISK UTVIKLING

Selskapet hadde ingen omsetning i regnskapsåret og driftsresultatet ble negativt kr. -58 685. Årsresultatet ble kr. 109 156 879. Selskapets likviditet og egenkapital er tilfredsstillende.

### FREMTIDSUTSIKTER:

Etter styrets mening gir fremlagte resultatregnskaper for selskapet med balanse og tilhørende noter



rettvisende informasjon om driften og stillingen ved årsskiftet.

#### FINANSIELL RISIKO:

Selskapet har ubetydelig valutaeksponering. Selskapet har kredittrisiko på utlån til andre selskaper i konsernet. Lånene løper med flytende rente.

Selskapet har betydelig lån og er derved eksponert mot renteendringer i kapitalmarkedet. Selskapets gjeld har flytende rente. Selskapet er i hovedsak finansiert ved lån fra konsernselskaper. Kreditrammene er fullt ut tilfredsstillende for selskapets behov. Det er etablert et konsernkontosystem for å styre likviditetsstrømmene i konsernet. Selskapet har pantsatt aksjer i datterselskapet som sikkerhet ovenfor långivere.

#### ÅRSRESULTAT OG DISPONERINGER

I 2022 hadde selskapet et resultat etter skattekostnad på kr 109 156 879 som foreslås disponert slik:

Disponering	Beløp
Tilleggsutbytte	72 500 000
Fra annen egenkapital	-36 656 879

Hokksund, 05.07.2022  
Styret i Trafo Holding AS

Simon Mark Gibbins  
Styreleder

Erling Christian Nettet  
Styremedlem

Gregory Dominique Malherbe  
Styremedlem



### RESULTATREGNSKAP

#### TRAFØ HOLDING AS

DRIFTSINNEKTER OG DRIFTSKOSTNADER	Note	2021/2022	2020/2021
Annen driftskostnad	1	58 685	44 929
<b>Sum driftskostnader</b>		<b>58 685</b>	<b>44 929</b>
<b>Driftsresultat</b>		<b>-58 685</b>	<b>-44 929</b>
<b>FINANSINNEKTER OG FINANSKOSTNADER</b>			
Inntekt på investering i datterselskap	6	115 000 000	17 599 021
Annen renteinntekt		171 607	137 899
Rentekostnad til foretak i samme konsern	6	3 373 333	3 224 450
<b>Resultat av finansposter</b>		<b>111 798 274</b>	<b>14 512 470</b>
Ordinært resultat før skattekostnad		111 739 589	14 467 540
Skattekostnad på ordinært resultat	2	2 582 710	3 182 859
<b>Ordinært resultat</b>		<b>109 156 879</b>	<b>11 284 681</b>
<b>Årsresultat</b>	5	<b>109 156 879</b>	<b>11 284 681</b>
<b>OVERFØRINGER</b>			
Tilleggsutbytte		72 500 000	100 000 000
Overført fra annen egenkapital		-36 656 879	88 715 319
<b>Sum overføringer</b>		<b>109 156 879</b>	<b>11 284 681</b>



## BALANSE

### TRAFØ HOLDING AS

EIENDELER	Note	31. mars 2022	31. mars 2021
<b>ANLEGGSMIDLER</b>			
<b>IMMATERIELLE EIENDELER</b>			
Utsatt skattefordel	2	0	87 364
<b>Sum immaterielle eiendeler</b>		<b>0</b>	<b>87 364</b>
<b>FINANSIELLE ANLEGGSMIDLER</b>			
Investeringer i datterselskap	3	353 692 501	353 692 501
<b>Sum finansielle anleggsmidler</b>		<b>353 692 501</b>	<b>353 692 501</b>
<b>Sum anleggsmidler</b>		<b>353 692 501</b>	<b>353 779 865</b>
<b>OMLØPSMIDLER</b>			
Andre kortsiktige fordringer		15 001 250	17 747 341
<b>Sum fordringer</b>		<b>15 001 250</b>	<b>17 747 341</b>
Bankinnskudd, kontanter o.l.		51 420 506	17 892 629
<b>Sum omløpsmidler</b>		<b>66 421 756</b>	<b>35 639 970</b>
<b>Sum eiendeler</b>		<b>420 114 257</b>	<b>389 419 835</b>

**BALANSE**

## TRAFO HOLDING AS

EGENKAPITAL OG GJELD	Note	31. mars 2022	31. mars 2021
<b>EGENKAPITAL</b>			
<b>INNSKUTT EGENKAPITAL</b>			
Aksjekapital	4	215 545 458	215 545 458
Egne aksjer	4	-11 908	-11 908
Overkurs		72 513 835	72 513 835
<b>Sum innskutt egenkapital</b>		<b>288 047 385</b>	<b>288 047 385</b>
<b>OPPTJENT EGENKAPITAL</b>			
Annen egenkapital		36 656 879	0
<b>Sum opptjent egenkapital</b>		<b>36 656 879</b>	<b>0</b>
<b>Sum egenkapital</b>	5	<b>324 704 264</b>	<b>288 047 385</b>
<b>GJELD</b>			
<b>ANNEN LANGSIKTIG GJELD</b>			
Langsiktig konserngjeld	6	90 000 000	98 453 025
<b>Sum annen langsiktig gjeld</b>		<b>90 000 000</b>	<b>98 453 025</b>
<b>KORTSIKTIG GJELD</b>			
Leverandørgjeld		6 250	0
Betalbar skatt	2	5 379 833	2 896 425
Annen kortsiktig gjeld		23 910	23 000
<b>Sum kortsiktig gjeld</b>		<b>5 409 993</b>	<b>2 919 425</b>
<b>Sum gjeld</b>		<b>95 409 993</b>	<b>101 372 450</b>
<b>Sum egenkapital og gjeld</b>		<b>420 114 257</b>	<b>389 419 835</b>

Hokksund, 05.07.2022  
Styret i Trafo Holding AS  
Simon Mark Gibbins  
Styreleder  
Erling Christian Nasset  
Styremedlem  
Gregory Dominique Malherbe  
Styremedlem



## INDIREKTE KONTANTSTRØM

### TRAFØ HOLDING AS

	Note	2021/2022	2020/2021
<b>KONTANTSTRØMMER FRA OPERASJONELLE AKTIVITETER</b>			
Resultat før skattekostnad		111 739 589	14 467 540
Periodens betalte skatt		11 938	179 404
Endring i leverandørgjeld		6 250	-15 625
Poster klassifisert som invest.- eller finans.aktiviteter		0	67 902 307
Endring i andre tidsavgrensingsposter		2 747 001	28 970
<b>Netto kontantstrøm fra operasjonelle aktiviteter</b>		<b>114 480 902</b>	<b>82 203 788</b>
<b>KONTANTSTRØMMER FRA FINANSIERINGSAKTIVITETER</b>			
Utbetalinger ved nedbetaling av langsiktig gjeld		8 453 025	0
Utbetalinger av utbytte		72 500 000	100 000 000
<b>Netto kontantstrøm fra finansieringsaktiviteter</b>		<b>-80 953 025</b>	<b>-100 000 000</b>
Netto endring i kontanter og kontantekvivalenter		33 527 877	-17 796 212
Beh. av kont. og kontantekvivalenter ved per. begynnel		17 892 629	35 688 840
<b>Beh. av kont. og kontantekvivalenter ved per. slutt</b>		<b>51 420 506</b>	<b>17 892 629</b>



## Regnskapsprinsipper

Årsregnskapet er satt opp i samsvar med regnskapslovens bestemmelser og god regnskapsskikk.

### BRUK AV ESTIMATER

I utarbeidelse av årsregnskapet har man brukt estimater og forutsetninger som har påvirket resultatregnskapet og verdsettelsen av eiendeler og gjeld, samt usikre eiendeler og forpliktelser på balansedagen i henhold til god regnskapsskikk. Områder som i stor grad inneholder slike skjønsmessige vurderinger, høy grad av kompleksitet, eller områder hvor forutsetninger og estimater er vesentlige for årsregnskapet, er beskrevet i notene.

### SKATT

Skattekostnaden i resultatregnskapet omfatter både periodens betalbare skatt og endring i utsatt skatt. Utsatt skatt er beregnet med 22 % på grunnlag av de midlertidige forskjeller som eksisterer mellom regnskapsmessige og skattemessige verdier, samt ligningsmessig underskudd til fremføring ved utgangen av regnskapsåret. Skatteøkende og skattereduserende midlertidige forskjeller som reverserer eller kan reverseres i samme periode er utlignet og nettoført. Netto utsatt skattefordel balanseføres i den grad det er sannsynlig at denne kan bli utnyttet.

### KLASSIFISERING OG VURDERING AV OMLØPSMIDLER

Omløpsmidler og kortsiktig gjeld omfatter normalt poster som forfaller til betaling innen ett år etter balansedagen, samt poster som knytter seg til varekretsløpet. Omløpsmidler vurderes til laveste verdi av anskaffelseskost og virkelig verdi. Kortsiktig gjeld balanseføres til nominelt beløp på transaksjonstidspunktet.

### DATTERSELSKAP OG TILKNYTTET SELSKAP

Datterselskap og tilknyttede selskaper vurderes etter kostmetoden i selskapsregnskapet. Investeringen er vurdert til anskaffelseskost for aksjene med mindre nedskrivning har vært nødvendig. Det er foretatt nedskrivning til virkelig verdi når verdifall skyldes årsaker som ikke kan forventes å være forbigående og det må anses nødvendig etter god regnskapsskikk. Nedskrivninger er reversert når grunnlaget for nedskrivning ikke lenger er til stede.

Utbytte, konsernbidrag og andre utdelinger fra datterselskap er inntektsført samme år som det er avsatt i givers regnskap. Overstiger utbytte / konsernbidraget andelen av opptjent resultat etter anskaffelsestidspunktet, representerer den overskytende del tilbakebetaling av investert kapital, og utdelingene er fratrukket investeringens verdi i balansen til morselskapet.

### FORDRINGER

Kundefordringer og andre fordringer oppføres til pålydende etter fradrag for avsetning til forventet tap. Avsetning til tap gjøres på grunnlag av en individuell vurdering av de enkelte fordringene. For øvrige kundefordringer utføres en uspesifisert avsetning for å dekke forventet tap på krav.

### KONTANTSTRØMOPPSTILLING

Kontantstrømoppstillingen er utarbeidet etter den indirekte metoden. Kontanter og kontantekvivalenter omfatter kontanter, bankinnskudd og andre kortsiktige, likvide plasseringer.



## Note 1 Lønnskostnader

Trafo Holding AS har ikke hatt lønns- eller personalkostnader i 2022 og det foreligger heller ingen slike forpliktelser. Foretaket er således ikke pliktig til å ha tjenstepensjonsordning etter lov om obligatorisk tjenstepensjon.

Godtgjørelse til revisor er fordelt på følgende:

	2021/2022
Lovpålagt revisjon	26 685
Andre tjenester	0

## Note 2 Skatt

Årets skattekostnad	2021/2022	2020/2021
Resultatført skatt på ordinært resultat:		
Betalbar skatt	2 495 346	2 896 425
Endring i utsatt skattefordel	87 364	286 434
<b>Skattekostnad ordinært resultat</b>	<b>2 582 710</b>	<b>3 182 859</b>
Skattepliktig inntekt:		
Ordinært resultat før skatt	111 739 589	14 467 540
Permanente forskjeller	-100 000 000	0
Avskåret rentefradrag	-397 109	-1 301 972
<b>Skattepliktig inntekt</b>	<b>11 342 480</b>	<b>13 165 569</b>
Betalbar skatt i balansen:		
Betalbar skatt på årets resultat	-804 654	-975 360
Betalbar skatt på mottatt konsernbidrag	3 300 000	3 871 785
Skyldig ilignet skatt fra tidligere år	2 884 487	0
<b>Sum betalbar skatt i balansen</b>	<b>5 379 833</b>	<b>2 896 425</b>
Beregning av effektiv skattesats		
Resultat før skatt	111 739 589	14 467 540
Beregnet skatt av resultat før skatt	24 582 710	3 182 859
Skatteeffekt av permanente forskjeller	-22 000 000	0
<b>Sum</b>	<b>2 582 710</b>	<b>3 182 859</b>
Effektiv skattesats	2,3 %	22,0 %

Skatteeffekten av midlertidige forskjeller som har gitt opphav til utsatt skatt og utsatte skattefordeler, spesifisert på typer av midlertidige forskjeller

	31. mars 2022	31. mars 2021	Endring
Avskåret rentefradrag	0	-397 109	-397 109
<b>Grunnlag for utsatt skattefordel</b>	<b>0</b>	<b>-397 109</b>	<b>-397 109</b>
<b>Utsatt skattefordel (22 %)</b>	<b>0</b>	<b>-87 364</b>	<b>-87 364</b>



## Note 3 Datterselskap, TS og FKV

	Kontor- kommune	Eier- andel	Anskaffelses kost	Balanseført verdi	Egenkapital	Resultat
NorateI AS	HOKKSUND	100,0 %	353 692 501	353 692 501	177 936 738	135 367 921
<b>Sum</b>			<b>353 692 501</b>	<b>353 692 501</b>	<b>177 936 738</b>	<b>135 367 921</b>

Aksjer i datterselskap er stilt som sikkerhet for konsernets gjeld.

## Note 4 Aksjonærer

### AKSJEKAPITALEN I TRAFØ HOLDING AS PR. 31.03 BESTÅR AV:

	Antall	Pålydende	Bokført
Ordinære aksjer	215 545 458	1,00	215 545 458
<b>Sum</b>		<b>215 545 458</b>	<b>215 545 458</b>

### EIERSTRUKTUR

De største aksjonærene i % pr. 31.03 var:

	Ordinære	Eierandel	Stemmeandel
DISCOVERIE NORDIC HOLDINGS LTD.	215 533 550	100,0	100,0
<b>Sum &gt;1% eierandel</b>	<b>215 533 550</b>	<b>100,0</b>	<b>100,0</b>
Sum øvrige (Egne aksjer)	11 908	0	0
<b>Totalt antall aksjer</b>	<b>215 545 458</b>	<b>100,0</b>	<b>100,0</b>

## Note 5 Egenkapital

	Aksjekapital	Overkurs	Egne aksjer	Annen egenkapital	Sum egenkapital
Pr. 31.03.2021	215 545 458	72 513 835	-11 908	0	288 047 385
Endringer ført mot EK	0	0	0	0	0
<b>Pr 01.04.2021</b>	<b>215 545 458</b>	<b>72 513 835</b>	<b>-11 908</b>	<b>0</b>	<b>288 047 385</b>
Årets resultat	0	0	0	109 156 879	109 156 879
Utbytte	0	0	0	-72 500 000	-72 500 000
<b>Pr 31.03.2022</b>	<b>215 545 458</b>	<b>72 513 835</b>	<b>-11 908</b>	<b>36 656 879</b>	<b>324 704 264</b>



## Note 6 Nærstående parter

Mellomværende med selskap i samme konsern	31.03.2022	31.03.2021
<b>Fordringer</b>		
Lån til datterselskap	0	0
<b>Sum</b>	<b>0</b>	<b>0</b>
<b>Gjeld</b>		
Langsiktig lån fra DiscoverIE	-90 000 000	-98 453 025
<b>Sum</b>	<b>-90 000 000</b>	<b>-98 453 025</b>

Lånet fra DiscoverIE er belastet med kr. 3 373 333 i renter for regnskapsåret 2021/2022, for regnskapsåret 2020/2021 ble det belastet kr. 3 224 450.

Det er inntektsført konsernbidrag og utbytte fra datterselskap med kr 115 000 000 for regnskapsåret 2021/2022 og kr 17 599 021 i for regnskapsåret 2020/2021.

## Konsernregnskap

Selskapet er morselskap i konsern. Selskapet er datterselskap av Discoverie Nordic Holdings Ltd, England (UK). Selskapet utarbeider ikke eget konsernregnskap da konsernet konsolideres inn i DiscoverIE. Konsernregnskapet er tilgjengelig på morselskapets web-sider.





Til generalforsamlingen i Trafo Holding AS

## Uavhengig revisors beretning

### Konklusjon

Vi har revidert Trafo Holding AS' årsregnskap som består av balanse per 31. mars 2022, resultatregnskap og kontantstrømoppstilling for regnskapsåret avsluttet per denne datoen og noter til årsregnskapet, herunder et sammendrag av viktige regnskapsprinsipper.

Etter vår mening

- oppfyller årsregnskapet gjeldende lovkrav, og
- gir årsregnskapet et rettviseende bilde av selskapets finansielle stilling per 31. mars 2022, og av dets resultater og kontantstrømmer for regnskapsåret avsluttet per denne datoen i samsvar med regnskapslovens regler og god regnskapsskikk i Norge.

### Grunnlag for konklusjonen

Vi har gjennomført revisjonen i samsvar med de internasjonale revisjonsstandardene International Standards on Auditing (ISA-ene). Våre oppgaver og plikter i henhold til disse standardene er beskrevet nedenfor under *Revisors oppgaver og plikter ved revisjonen av årsregnskapet*. Vi er uavhengige av selskapet slik det kreves i lov, forskrift og International Code of Ethics for Professional Accountants (inkludert internasjonale uavhengighetsstandarder) utstedt av the International Ethics Standards Board for Accountants (IESBA-reglene), og vi har overholdt våre øvrige etiske forpliktelser i samsvar med disse kravene. Innhentet revisjonsbevis er etter vår vurdering tilstrekkelig og hensiktsmessig som grunnlag for vår konklusjon.

### Øvrig informasjon

Styret (ledelsen) er ansvarlig for informasjonen i årsberetningen. Øvrig informasjon omfatter informasjon i årsrapporten bortsett fra årsregnskapet og den tilhørende revisjonsberetningen. Vår konklusjon om årsregnskapet ovenfor dekker ikke informasjonen i årsberetningen.

I forbindelse med revisjonen av årsregnskapet er det vår oppgave å lese årsberetningen. Formålet er å vurdere hvorvidt det foreligger vesentlig inkonsistens mellom årsberetningen og årsregnskapet og den kunnskap vi har opparbeidet oss under revisjonen av årsregnskapet, eller hvorvidt informasjon i årsberetningen ellers fremstår som vesentlig feil. Vi har plikt til å rapportere dersom årsberetningen fremstår som vesentlig feil. Vi har ingenting å rapportere i så henseende.

Basert på kunnskapen vi har opparbeidet oss i revisjonen, mener vi at årsberetningen

- er konsistent med årsregnskapet og
- inneholder de opplysninger som skal gis i henhold til gjeldende lovkrav.

### Ledelsens ansvar for årsregnskapet

PricewaterhouseCoopers AS, Strømsø Torg 9, Postboks 2078 Strømsø, NO-3003 Drammen  
T: 02316, org. no.: 987 009 713 MVA, www.pwc.no  
Statsautoriserte revisorer, medlemmer av Den norske Revisorforening og autorisert regnskapsførerselskap



Uavhengig revisors beretning - Trafo Holding AS



Ledelsen er ansvarlig for å utarbeide årsregnskapet og for at det gir et rettviseende bilde i samsvar med regnskapslovens regler og god regnskapsskikk i Norge. Ledelsen er også ansvarlig for slik internkontroll som den finner nødvendig for å kunne utarbeide et årsregnskap som ikke inneholder vesentlig feilinformasjon, verken som følge av misligheter eller utilsiktede feil.

Ved utarbeidelsen av årsregnskapet må ledelsen ta standpunkt til selskapets evne til fortsatt drift og opplyse om forhold av betydning for fortsatt drift. Forutsetningen om fortsatt drift skal legges til grunn for årsregnskapet så lenge det ikke er sannsynlig at virksomheten vil bli avvirket.

---

*Revisors oppgaver og plikter ved revisjonen av årsregnskapet*

Vårt mål er å oppnå betryggende sikkerhet for at årsregnskapet som helhet ikke inneholder vesentlig feilinformasjon, verken som følge av misligheter eller utilsiktede feil, og å avgi en revisjonsberetning som inneholder vår konklusjon. Betryggende sikkerhet er en høy grad av sikkerhet, men ingen garanti for at en revisjon utført i samsvar med ISA-ene, alltid vil avdekke vesentlig feilinformasjon som eksisterer. Feilinformasjon kan oppstå som følge av misligheter eller utilsiktede feil. Feilinformasjon blir vurdert som vesentlig dersom den enkeltvis eller samlet med rimelighet kan forventes å påvirke økonomiske beslutninger som brukerne foretar basert på årsregnskapet.

For videre beskrivelse av revisors oppgaver og plikter vises det til:  
<https://revisorforeningen.no/revisjonsberetninger>

Drammen, 5. juli 2022  
**PricewaterhouseCoopers AS**

Paal Ødegård  
Statsautorisert revisor  
(elektronisk signert)



 Securely signed with Brevio

Revisjonsberetning

**Signers:**

<b>Name</b>	<b>Method</b>	<b>Date</b>
Ødegård, Paal	BANKID	2022-07-05 15:02

**This document package contains:**

- Closing page (this page)
- The original document(s)
- The electronic signatures. These are not visible in the document, but are electronically integrated.



This file is sealed with a digital signature.  
The seal is a guarantee for the authenticity  
of the document.



# Enabling technology for a sustainable world



**discoverIE**

**discoverIE Group plc**

Annual Report and Accounts  
for the year ended 31 March 2022



## CONTENTS

Highlights	02
Investment Case	03
Group at a Glance	04
Chairman's Statement	10
Our Business Model	14
Market Review	16
Our Strategy	18
Our Strategy in Action	20
Key Strategic Indicators	24
Key Performance Indicators	25
Strategic and Operational Review	26
Financial Review	36
Risk Management	42
Viability Statement	52
Principal Risks and Uncertainties	54
Sustainability Report	60
Stakeholder Engagement	75
Non-financial Information Statement	78
Section 172 Statement	79
The Board	82
The Group Executive Committee	84
Corporate Governance Report	86
Audit and Risk Committee Report	97
Nomination Committee Report	104
Directors' Report	106
Directors' Remuneration Report	109
Statement of Directors' Responsibilities in Respect of the Financial Statements	133
Independent Auditor's Report to the members of discoverIE Group plc	134
Consolidated Income Statement	146
Supplementary Income Statement Information	146
Consolidated Statement of Comprehensive Income	147
Consolidated Statement of Financial Position	148
Consolidated Statement of Changes in Equity	149
Consolidated Statement of Cash Flows	150
Notes to the Group Financial Statements	151
Company Balance Sheet	213
Company Statement of Changes in Equity	214
Notes to the Company Financial Statements	215
Five Year Record	218
Principal Locations	219
Financial Calendar 2022/23	220
Corporate Information	220

# ANNUAL REPORT

is an international leading designer and manufacturer of customised electronics for industrial applications. We create innovative electronics that deliver value to our customers, while making positive impacts on the environment, society and people's lives.

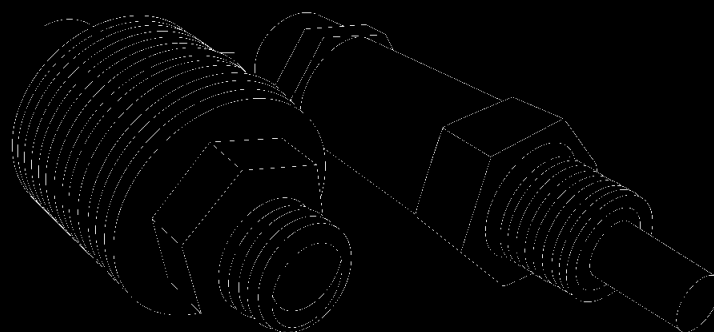

[www.discoverIEplc.com](http://www.discoverIEplc.com)

It contains a wide range of information of interest to institutional and private investors including:

- Latest news and press releases
- Reports and presentations



# Our vision is to be a leading innovator in electronics, internationally.

Over the past 11 years, we have transformed from a European distribution business to an electronic engineering, design and manufacturing group with our own product development and a global manufacturing footprint.

We aim to go further, to become the world's leading innovator in customised electronics by continuing to build capabilities and strengthen our presence beyond Europe.

The change of **business model** enables us to move up the value chain and improve our margins

Read more on Our Journey

**Page 05**

Read more on Our Business Model

**Page 14**

We **target markets** that are exhibiting structural growth and are driven by technology

Read more on Our Markets

**Page 16**

We're **committed** to making a positive impact through our operations and our products

Read more on Sustainability

**Page 60**

Our strategy of **focusing on sustainable growth markets**, bolstered by earnings enhancing acquisitions, has enabled us to achieve **substantial growth**

Read more on Our Strategy

**Page 18**

Read more on Corporate Governance

**Page 86**

## HIGHLIGHTS

<p><b>REVENUE<sup>1</sup></b></p> <p><b>£379.2m</b></p> <p>(FY21: £302.8m)</p> <p><b>+25%</b></p>	<p><b>UNDERLYING OPERATING PROFIT<sup>1 2</sup></b></p> <p><b>£41.4m</b></p> <p>(FY21: £30.8m)</p> <p><b>+34%</b></p>
<p><b>UNDERLYING EPS<sup>1 2</sup></b></p> <p><b>29.4p</b></p> <p>(FY21: 22.4p)</p> <p><b>+31%</b></p>	<p><b>REPORTED OPERATING PROFIT<sup>1</sup></b></p> <p><b>£20.9m</b></p> <p>(FY21: £17.1m)</p> <p><b>+22%</b></p>
<p><b>REPORTED FULLY DILUTED EPS</b></p> <p><b>26.3p</b></p> <p>(FY21: 13p)</p> <p><b>+102%</b></p>	<p><b>FULL YEAR DIVIDEND PER SHARE</b></p> <p><b>10.8p</b></p> <p>(FY21: 10.15p)</p> <p><b>+6%</b></p>



**“This has been a year of record growth, with excellent progress towards our key strategic targets.”**

**Nick Jefferies**  
Group Chief Executive

### Notes

<sup>1</sup> These figures relate to continuing operations. Continuing operations excludes the results of the Acal BFI and Vertec SA businesses, and profit on sale, following their disposals during the year. These two businesses have been treated under IFRS 5 as discontinued operations.

<sup>2</sup> 'Underlying Operating Profit', 'Underlying Operating Margin', 'Underlying Profit before Tax' and 'Underlying EPS' are non-IFRS financial measures used by the Directors to assess the underlying performance of the Group. These measures relate to continuing operations and exclude acquisition-related costs (a amortisation of acquired intangible assets of £14.0m and acquisition expenses of £6.5m) totalling £20.5m. Equivalent underlying adjustments within the FY 2020/21 underlying results totalled £137m.

<sup>3</sup> Organic growth for the Group compared with last year is calculated at constant exchange rates ("CER") and is shown excluding the first 12 months of acquisitions post completion (Phoenix was acquired in October 2020, Limitor in February 2021, CPI in May 2021, Antenova in August 2021 and Beacon in September 2021). Organic growth compared with two years ago excludes the first 24 months of acquisitions so also excludes Sans-Tech acquired in October 2019. The average Sterling rate of exchange against the Euro strengthened by 5% compared with the average rate last year, by 2% on average against the three Nordic currencies, and by 5% compared with the US dollar rate for last year.

<sup>4</sup> Target is for Scope 1 and Scope 2 carbon emissions and is based on an intensity measure of tonnes of CO<sub>2</sub> equivalent per £m revenue (tCO<sub>2</sub>e/£m revenue). Historic figures have been adjusted to exclude disposals in FY 2021/22 and acquisitions completed in the last 12 months.

<sup>5</sup> Free cash flow is cash flow before dividends, acquisitions, disposals and equity issuance. Free cash flow conversion rate of 136% of net profit in FY 2020/21 (linked to an inflow of working capital with organic sales down 4%); 77% in FY 2021/22 (linked to an outflow of working capital with organic sales up 18%) giving 102% for the 2 year period (with organic sales up 14%).

<sup>6</sup> Gearing ratio is defined as net debt divided by underlying EBITDA (annualised for acquisitions).

<sup>7</sup> Growth rates for the period FY 2017/18 to FY 2021/22 excludes the Covid year FY 2021/22 so the growth from FY 2019/20 to FY 2021/22 is treated as one year.

<sup>8</sup> Unless stated, growth rates refer to the comparable prior year period.

### Record growth in orders & sales driven by focus on structurally growing target markets

- 76% of sales into UNSDG aligned sectors of renewables, medical, transport, industrial & connectivity
- Organic<sup>3</sup> orders: +36% (v FY 2020/21) and +32% (v pre-Covid period FY 2019/20)
- Organic sales: +18% (v FY 2020/21) and +14% (v FY 2019/20)
- Total sales +25% (v FY 2020/21) and +25% (v FY 2019/20)

### Delivering strong financial performance

- Underlying operating profit from continuing operations: +34%
- Underlying EPS from continuing operations: +31%

### Excellent progress towards key strategic targets

- Underlying operating margin increased by 0.7ppt to 10.9% (target: 13.5%)
- Like-for-like carbon emissions<sup>4</sup> reduced by 33% since CY 2019 (v 50% target by 2025)

- Free cash conversion<sup>5</sup> over two years of 102% of net profit (v 85% target)

### Three international acquisitions completed for £85m, well supported equity placing for net £53m

- Beacon, Antenova and CPI; now fully integrated

### Sale of Acal BFI completes exit from the business of distribution

- Continuing operations<sup>1</sup> arranged into two new divisions: Magnetics & Controls ("M&C") and Sensing & Connectivity ("S&C")

### Group well positioned for further growth

- Record order book of £224m (organic: +62% v Mar 2021; +71% v Mar 2020)
- Pipeline of acquisition opportunities in development
- Gearing<sup>6</sup> of 0.6x, well below our target of 1.5x to 2.0x; significant funding headroom available
- New financial year started well – continued strong organic revenue growth

## INVESTMENT CASE

01

### Sustainable growth markets

Increasing electronic content and electrification of products and processes drives demand for electrical and electronic components. We prioritise four markets with structural, sustainable growth.

Predicted growth in our target markets

Target markets:

02

### Differentiated product offering

Customised electronic solutions based on commercially proven technologies, designed to meet customers' unique requirements. We manufacture and supply the components throughout the life of the end products.

Longest customer relationship

03

### Proven strategy for growth

Grow well ahead of GDP through the economic cycle by focusing on target markets and an expanding product offering, bolstered by earnings enhancing acquisitions. Proven track record of delivering strategic and financial targets.

Revenue growth<sup>1</sup> of

CAGR from FY 2014-FY 2022

04

### Strong financials

Sustainable, profitable growth and excellent cash generation. The strong balance sheet with a gearing of well below our 1.5x – 2x target allows ample headroom for further acquisitions.

Underlying operating profit growth<sup>1</sup> of

CAGR from FY 2018-FY 2022

Free cash flow conversion<sup>2</sup> of

on average over four years to FY 2022

05

### Consistent shareholder return

Disciplined capital allocation with a track record of value enhancing acquisitions drive capital appreciation and progressive dividends.

Dividend growth of

CAGR FY 2012-FY 2022

Total shareholder return<sup>3</sup> of

FY 2012-FY 2022

➔ Read more in Our Business Model on pages 14 to 15

- <sup>1</sup> Design and manufacturing businesses only, excludes Custom Supply business which was sold in March 2022.
- <sup>2</sup> Free cash flow conversion is defined as net cash flow before dividend payments, net proceeds from equity fund raising, acquisition costs and business disposal proceeds divided by underlying profit after tax.
- <sup>3</sup> Share price of last trading day of the year and dividend of the year.

## GROUP AT A GLANCE

discoverIE is an international group of businesses designing and manufacturing innovative electronic components for industrial applications. We offer customers differentiated products in key growth markets on a global scale.

### Our purpose

To create innovative electronics that help to improve the world and people's lives

### Our vision

To be a leading innovator in electronics, internationally

### Our mission

To design and supply innovative electronics that help our customers create ever better technical solutions

### Our strategy

To grow our business in customised electronics by focusing on markets with sustained growth prospects, complemented by value enhancing acquisitions.

Our strategy has four pillars:



Grow sales well ahead of GDP



Move up the value chain



Acquire high quality businesses



Further internationalise

➔ Read more in Our Strategy on pages 18 to 23

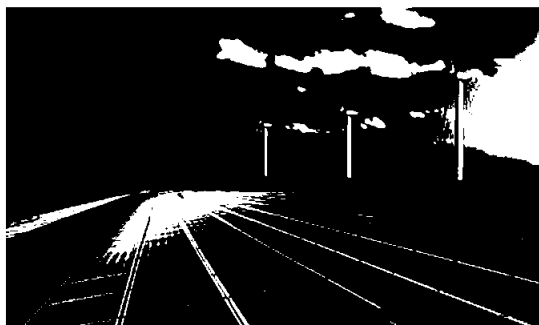

### Our approach to sustainability

Guided by our Purpose, sustainability is integrated into our business model, strategy and risk management. Targets and performance are linked to the remunerations of the Group Executive Committee ("GEC") and the management of each business unit. Our sustainability programme has three pillars:

#### Our Planet

Creating a positive impact on our environment

#### Our People

Keeping our people safe and happy

#### Our Products

Ensuring product reliability and sustainability

### Our values

- We have high ethical standards and integrity
- We strive for the best
- We are Green
- We care for our colleagues
- We are innovative
- We are a trusted business partner

### Our culture

#### The culture we aim to build

- Honest, reliable and trusting
- Decentralised decision-making close to the customer
- Open, constructive communication and willingness to listen
- Treat everybody equally and value the importance of diversity
- Performance driven



We have transformed the Group over the past 11 years, from a European distribution business into an electronic engineering group, with our own product development and a global manufacturing footprint.

We have broadened our product range, customer base and geographical presence over the last

## 11 years

Number of acquisitions with design and manufacturing capabilities

## 19

Average return on capital employed in last five years

## c.15%

### Disposal of Custom Supply

In March 2022, the Group completed the sale of the Custom Supply business, which included Acal BFi, to H2 Equity Partners for a total consideration of £50m on a debt free cash free basis. The sale concluded the Group's exit from the distribution business, leaving the Group focused wholly on design and manufacture, the principal driver of the Group's financial performance in the last five years.

## Our journey

discoverIE (formerly Acal) was established in 1986 as an electronic component and IT distributor, capitalising on the rise of digitalisation. As demands rose, the distribution market became highly competitive.

Since 2011, the Group has shifted its focus from distribution to design and manufacturing ("D&M"). The D&M business model allows the Group to move up the value chain and provide more value-added products to customers. It divested several businesses deemed to be non-core and redirected capital into building its own D&M capabilities, through both organic growth and acquisitions.

The sale of the Custom Supply business marked the Group's exit from the distribution business. discoverIE is now a pure design and manufacturing company that focuses on sustainable industrial markets.

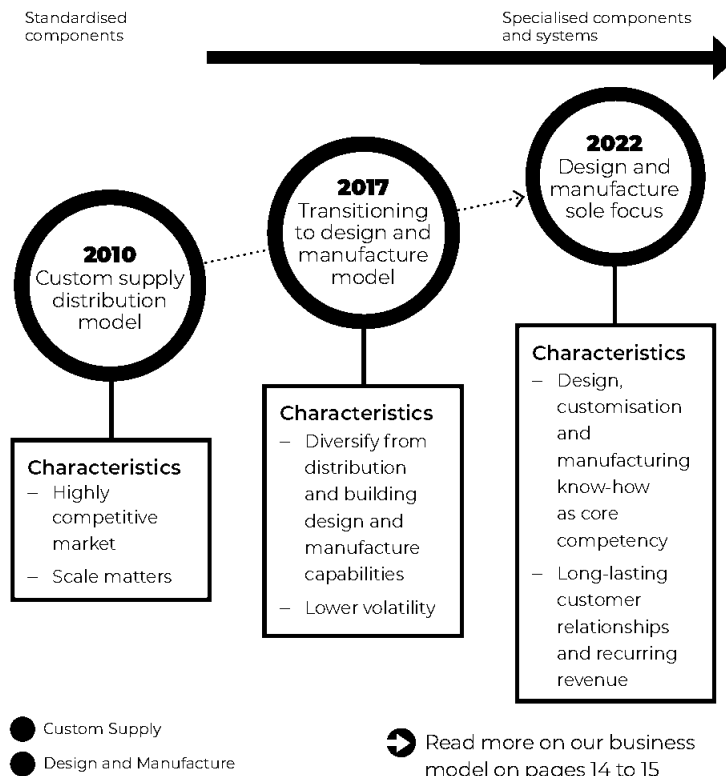



Strategic Report

# GROUP AT A GLANCE

## Our divisions

discoverIE operates two segments: Magnetics & Controls (M&C) and Sensing & Connectivity (S&C).

Following the disposal of the distribution business, the Group divided the 20 business units within the ongoing D&M division into two operating segments: M&C and S&C. The new structure enables greater collaboration between business units and improves visibility for the Group's growth initiatives.

The new divisions align business units by product and technology area.

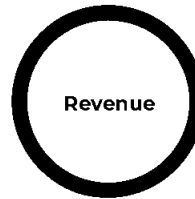

**Magnetics & Controls**

**Sensing & Connectivity**

Magnetic components for use in power conversion, signal conditioning and switching

Components for use in remote control, monitoring, communication and interface control

Sensing components for sensing, measuring and controlling temperature, movement, pressure, force, position, load, weight and incline, x-ray detection and imaging

Connectivity components for switching, transmitting & receiving wirelessly, fibre optic components, electromagnetic shielding, cable connection

## MAGNETICS & CONTROLS

Comprises the magnetic components and the embedded computing and interface controls businesses. It consists of eight businesses, across 16 countries with 20 manufacturing sites.

FY19/20	£192.9m
FY20/21	£190.4m
FY21/22	£234.7m

FY19/20	£21.2m
FY20/21	£23.4m
FY21/22	£29.8m

- Liquid-cooled power reactors and transformers for wind power systems
- Trackballs for ultrasound system control panel
- Ruggedised control board with anti-vibration technology and waterproof sealing for marine applications



### How our customised products work

#### Embedded microsystem

##### Application: Implantable vision restoration

An embedded solution for a ground breaking implantable medical device that delivers artificial vision for patients with retinitis pigmentosa, a medical condition that can cause severe vision impairment. The device uses an ocular implant that receives wireless signals from a pair of eyeglasses and subsequently stimulates remaining retinal cells to restore visual function.

##### Customer benefits:

We developed an embedded system that is less than one square inch, that can be fitted into the glasses without compromising their compact design. It has reliable processing power and a long product life, also meeting stringent US and European regulatory requirements. We provide support throughout the entire product life cycle.

## SENSING & CONNECTIVITY

Comprises a cluster of five sensing component businesses and seven communication and connectivity businesses, across 9 countries with 10 manufacturing sites.

FY19/20	£110.5m
FY20/21	£112.4m
FY21/22	£144.5m

FY19/20	£17.9m
FY20/21	£15.5m
FY21/22	£23.3m

- Encoders in solar trackers to obtain reliable positioning of tilt and azimuth angles
- X-ray detectors for bone density measurement and X-ray scans
- Wireless antennas for robotic control



### How our customised products work

#### Motion sensing and control

##### Application: Wind scanner

A full scale multiple LIDAR-based laser scanner system to measure wind turbulence in three dimensions around wind turbines to further understand wind turbulence effects on existing turbines on wind farm sites and complex terrains worldwide. The captured data is then shared with wind systems designers and scientists to develop turbines with higher efficiencies and improved safety and life span.

##### Customer benefits:

We design, prototype and manufacture the positioning systems with associated motion controls and all interfacing cabling, as well as on-site assembly and functional testing.



Strategic Report

## GROUP AT A GLANCE

### Our global reach

discoverIE is an international electronics engineering group, designing and manufacturing customised electronic components for industrial applications.

**30**

Manufacturing sites

**20**

Countries in which we operate

**66**

Countries in which our products are sold

**4,886**

Employees globally





Strategic Report

## CHAIRMAN'S STATEMENT

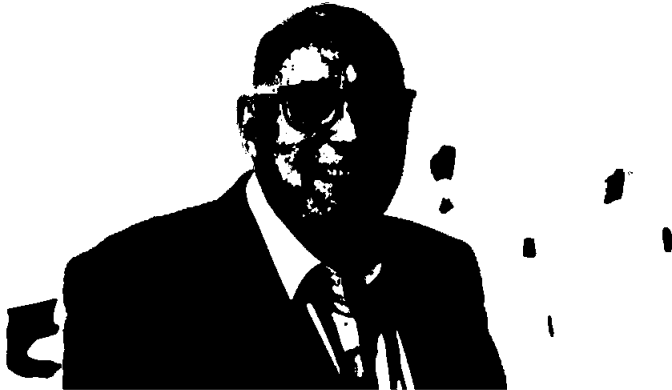

**“The Board is excited by the opportunity to continue building a global business and contribute to a sustainable environment.”**

Malcolm Diamond MBE  
Chairman

**This year saw discoverIE recover very strongly from the effects of Covid the previous year, to deliver record organic growth in orders, sales and order book compared with both last year and the pre-Covid period two years ago, resulting in record Group profitability for its continuing operations.**

**GROUP REVENUE**

**£379.2m**

**UNDERLYING OPERATING PROFIT**

**£41.4m**

The exit from the business of distribution has enabled the Group to be fully focussed on its core strategy of designing and manufacturing customised electronics for industrial applications through two new divisions, with disposal proceeds available for re-investment into further high quality, higher margin acquisitions.

Cash generation has again been strong, reflecting both the quality of earnings generated and the efficient, capital-light nature of the Group's operating model. Gearing is now at its lowest level in eight years, with significant funding headroom for further acquisitions.

The Group is committed to reducing the impact of its business operations on the environment. Along with its focus on selling into markets that are aligned with a sustainable future, the Group has made excellent progress towards its target of reducing its carbon emissions by 50% by 2025 and is currently developing its net zero plan.

**Strategy**

discoverIE is a customised electronics business operating internationally, focusing on structurally growing, sustainable markets driven by increasing electronic content and where there is an essential need for its products. The Group's product range is highly differentiated, being customised for specific applications.

With the Group's target markets being worldwide and major customers operating internationally, the business is expanding both within and beyond Europe, building an international electronics group supplying complex, value-added solutions for customers.



Alongside organic growth, acquisitions are another key factor in building discoverIE. Since 2011, the Group has acquired 19 specialist, high margin design and manufacturing businesses which have been integrated successfully and have helped to accelerate its growth. discoverIE has a disciplined approach to acquisitions and continues to see significant scope for further expansion with several opportunities in development.

The Group's capital-light model delivers strong cash flows which management looks to reinvest into accelerating the strategy and delivering further value creation for shareholders.

### **Sustainability and Positive Impact**

This is the first year that the UK requirement of TCFD reporting (Task Force on Climate-Related Financial Disclosures) comes into force. The Group has undertaken a preliminary assessment of the resilience of its business model and strategy, and potential impact of climate change over the short and medium term. It has concluded that, while the Group may be exposed to certain risks during the transition to a low carbon economy, such risks are considered to be low and more than outweighed by the opportunities presented to the Group.

The Group's business model of designing and manufacturing customised electronics for industrial applications is well established. Aligning its purpose with the UN Sustainable Development Goals ("UN SDGs"), the Group creates a positive impact on the world around us and people's lives through both our products and our operations.

By creating innovative electronics and focusing on our four target markets, we play an essential role in achieving a cleaner, healthier, and more sustainable world.

The Group also aims to be a socially responsible employer, adhering to the highest ethical standards both internally and externally through its supply chain, with excellent employee relations and a commitment to increasing diversity in the workplace.

Emphasising its importance to the business, a Sustainability Committee of the Board has been established with responsibility for setting the sustainability strategy, overseeing its implementation and ensuring progress. Reporting to the Board, the Group Executive Committee also has responsibility for Environmental, Social and Governance ("ESG") implementation and each member has the achievement of ESG objectives included in their annual incentive plans.

Recognising the Group's achievements and strong strategic focus on sustainable development, MSCI awarded the Group an "A" rating in its 2022 ESG Rating assessment. It acknowledged the Group's strong performance against global industry peers in various areas, including opportunities in clean tech and corporate governance.

### **Acquisitions and disposals**

The Group made three acquisitions during the year for a total consideration of £85m on a cash free, debt free basis. Control Products Inc ("CPI"), a US based designer and manufacturer of custom, rugged sensors and switches was acquired in May 2021 and Antenova Limited, a UK and Taiwan based designer and

manufacturer of antennas and radio frequency (RF) modules was acquired in August 2021. Both businesses now operate within the Sensing & Connectivity division. Beacon EmbeddedWorks ("Beacon"), a US based designer and manufacturer of custom embedded computing boards, was acquired in September 2021 and now operates within the Magnetics & Controls division.

All three businesses retain their distinct identity and high-quality management teams, and have now been fully integrated into the Group. Their complementary product ranges and wider access to customers is expected to create cross-selling opportunities in the Group's target markets and drive further growth.

We are delighted to welcome the employees of all three businesses into the Group.

Additionally during the year, the Group completed the disposals of the Acal BFI and Vertec SA distribution businesses, which has enabled the Group to be fully focussed on its core strategy of designing and manufacturing custom electronics for industrial applications.

We wish all employees of Acal BFI and Vertec SA well for the future and thank them for their excellent and long-standing contributions to the Group.

### **Group Results Summary**

Continuing Group sales for the year increased by 25% to £379.2m (+28% CER), with underlying operating profit, which excludes acquisition related costs, increasing by 34% to £41.4m. Underlying profit before tax increased by 38% to £37.6m, with underlying earnings per share for the year increasing by 31% to 29.4p (FY 2020/21: 22.4p).



## CHAIRMAN'S STATEMENT

After underlying adjustments for acquisition costs, together with taxation costs and the inclusion of net profits from discontinued operations, net profit for the year on a reported basis increased by 110% to £25.2m (FY 2020/21: £12.0m) with fully diluted earnings per share increasing by 102% to 26.3p (FY 2020/21: 13.0p).

Strong free cash flow over the last two years represents 102% of underlying net profits, well ahead of the Group's 85% target despite strong organic sales growth requiring investment in working capital. Net debt at 31 March 2022 was £30.2m (31 March 2021: £47.2m) and a gearing ratio of 0.6x, well below our target range of 1.5x to 2.0x, leaves considerable headroom for further accretive acquisitions.

Alongside the acquisitions of Antenova in August 2021 and Beacon in September 2021, the balance sheet was further strengthened by way of a well-supported equity placing that raised net proceeds of £53.4m. Together with strong organic cash flows, these acquisitions provide the Group with an excellent platform from which to continue to execute its growth strategy. On behalf of the Board, I would like to thank shareholders for their support.

### Increased Dividend

The Board is recommending a 6% (0.45 pence) increase in the final dividend per share to 7.45 pence per share, giving a full year dividend per share of 10.8 pence, and representing a cover against underlying earnings of 2.7 times (FY 2020/21: 2.4 times). Since 2010, the annual dividend per share has more than doubled.

The Board believes that, as an acquisitive growth company, maintaining a progressive dividend policy is appropriate along with a long-term dividend cover of over three times on an underlying basis. This approach along with the continued growth of the Group should enable funding of both sustainable dividend growth and a higher level of investment in acquisitions from internally generated resources.

The final dividend is payable on 2 August 2022 to shareholders registered on 24 June 2022.

### Employees and Culture

On behalf of the Board, I would like to thank everybody at discover!E for their commitment and hard work through the unprecedented circumstances of the last two years when their flexibility, resilience, initiative and support have demonstrated, beyond all expectations, their quality, capability and dedication.

The Group comprises approximately 4,900 employees in 20 countries around the world and by adopting an entrepreneurial and decentralised operating environment, together with rigorous planning, review, support, investment and controls, the Group has created an ambitious and successful culture, with a commitment to increasing diversity across the organisation.

We aim to achieve a culture across the Group that:

- is entrepreneurial
- treats everybody equally and recognises the importance of diversity
- is honest, reliable, trusting and non-political
- enables decision making close to the customer through a decentralised structure
- enables open, constructive communication with a willingness to listen
- is performance driven

### Board and Group Executive Committee Strengthened; Chairman-elect announced.

Two additional senior level appointments were made during the year.

- Rosalind Kainyah MBE joined the Board in January 2022 as a Non-Executive Director. Rosalind brings many years of senior management, executive



and board experience in international environments. She has extensive experience in sustainability matters and currently runs Kina Advisory, a consultancy advising on ESG matters for businesses. Previously, Rosalind held senior executive roles at Tullow Oil, as Vice President, External Affairs & Corporate Social Responsibility, and at De Beers SA in various roles, latterly as President of its US business. On 1 April 2022, Rosalind was appointed chair of the newly established Sustainability Committee of the Board with responsibility for the Group's sustainability strategy, policies and performance of discoverIE and driving further progress.

- Paul Hill joined the Group Executive Committee ("GEC") in December 2021 and since February 2022, has been leading the newly established Sensing & Connectivity division. Paul brings extensive experience in the electronics and technology sector having held senior operational roles in both hardware and software companies.

Having started his career in electronics engineering, Paul has worked in electronic components, smart card systems and electronic design and manufacturing businesses.

More recently Paul led private equity held businesses and joined from Antenova, our recent acquisition, where he was Chief Executive Officer. Paul also has Group-wide responsibility for evolving our approach to developing design opportunities.

After seven enjoyable years with discoverIE during which time the Group has ascended into the FTSE250, I am today announcing my intention to step down as Chairman of the Group from 1 November 2022. I am pleased to announce that my colleague Bruce Thompson will become Chairman from that date.

Bruce has been a Non-Executive Director of the Group since February 2018, and the Group's Senior Independent Director since March 2019. Bruce is also Chairman of Avon Protection plc and prior to joining the Group, was Chief Executive Officer of Diploma plc for over 20 years. I am also pleased to announce that Tracey Graham, a member of the Board since November 2015 and Chair of the Remuneration Committee, will succeed Bruce as Senior Independent Director.

### Summary

The Group is building a high-quality business that is delivering strong results with excellent prospects. The customised electronics market remains highly fragmented, providing scope to further build capability and extend geographic coverage through disciplined acquisitions.

The Board is excited by the opportunities ahead to continue building a global business that attracts and retains high quality employees, delivers exceptional value to our customers, grows long term returns for our shareholders, contributes to the creation of a sustainable environment and adheres to the highest standards.

Throughout the year, the Group has again demonstrated the quality and resilience of its businesses and, with good levels of operational and funding capacity, is well positioned for continued growth in the year ahead.

**Malcolm Diamond**  
Chairman

14 June 2022



Strategic Report

## OUR BUSINESS MODEL

Our business model of designing and manufacturing customised products has proven to be resilient and flexible, evident in our performance track record, even during the most challenging times of the pandemic.

### Our inputs

#### Our colleagues

We have 4,886 colleagues worldwide and the number is still growing. Many of them are long-serving and have a high level of technical knowledge and experience in their fields. We encourage local employment and talent development so that our colleagues understand the market where they operate.

#### Expertise and know-how

We have been active in the electronics market for over three decades and have accumulated a vast amount of expertise and knowledge. This allows us to develop new products in response to changing technologies.

#### Intellectual property

We have unique technology patents, which are used in many of our customised products. In most instances, we also retain the intellectual property rights of the products designed for customers' specific requirements.

#### Manufacturing capability

We have 30 manufacturing facilities in 20 countries, including China, India, Mexico, Poland, Sri Lanka, the Netherlands, the UK, and the USA, producing high-quality products consistently and reliably in locations close to our customers.

#### Financials

We have a strong balance sheet, supported by high cash generation, which allows us to continue to invest in our people and capabilities and expand geographically.

#### Sustainability approach

Our purpose and values provide a clear framework for decision making. We strive for the highest performance and ethical standards, while making a positive difference to the world and people's lives.

## Value creation for our stakeholders

Improved usability and effectiveness of the products we design and manufacture results in enhanced performance of our customers' applications, which also benefits their own customers and end users.

We enable customers to differentiate their own products from their competitors.

Quality, reliability, and efficiency are achieved and ensured by having full control of the end-to-end process of designing and manufacturing.

Flexible and short lead times.

We have created an environment that encourages innovation and ambition. Each employee has the opportunity to grow and be their best while knowing that their safety and wellbeing are cared for. Our decentralised operating model engenders trust and loyalty. Employees near the frontline are empowered to make decisions and take initiative.

We consistently generate attractive returns for our shareholders over the long term while minimising risks. As our manufacturing activities have a low carbon nature and our products are used in many decarbonisation activities, we also contribute to the net-zero goals of our shareholders.

We contribute positively to the communities in which we operate through local employment, tax revenue and community engagement. We also play our role in decarbonisation through our operation processes and our products.

Our geographical footprint allows us to engage with suppliers at their locations. We enable smaller suppliers to expand their global network via our international supply chain.

## Our main activities

We design and manufacture electrical and electronic components for original equipment manufacturers ("OEMs").

Core to our value proposition is the understanding of our customers' design challenges and the design and manufacture of engineered products to meet their needs. These are then supplied over the life of the customer's production, typically five to seven years.

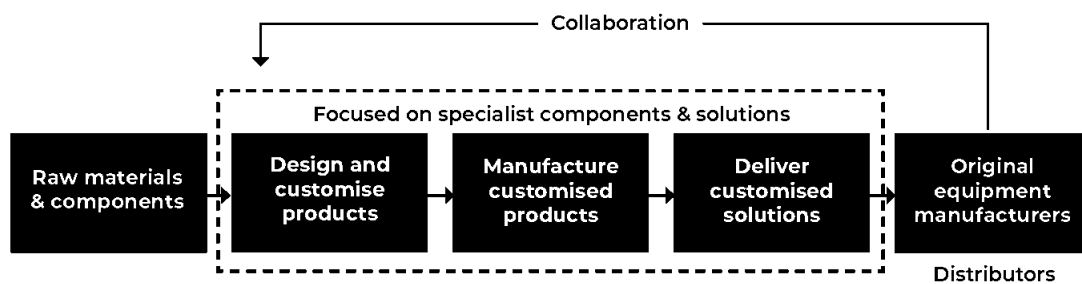

Our products contain copper, aluminium and plastics. Some of our products also use components such as printed circuit boards ("PCB") and microprocessing chips.

We work closely with our customers, who are primarily OEMs, to develop appropriate solutions to solve their technical challenges, which often require adaptations of standard products or completely new ones.

With know-how and in-house manufacturing capabilities, we have control of the production process, ensuring both high standards and reliability. Quality is assured through our advanced testing procedures.

We supply customers with customised products consistently throughout the project's lifetime and provide support thereafter.

We work with and sell directly to OEMs who are often makers of larger systems, such as wind systems, solar equipment, and MRI scanners. In some countries, we also sell through distributors.

### Long-lasting customer relationships

We have been supplying many of our customers for decades. Our long-lasting customer relationships are built upon **our product knowledge and expertise**, manufacturing know-how, product quality and reliability and reliable delivery. Our highly skilled engineers work closely with customers, developing a deep understanding of their industry and sharing knowledge and insights.

### Long product cycles and repeat revenues

Our products are a small but essential part of larger systems which have a life cycle of typically seven years. Once designed into the system, **they stay throughout the lifetime of the system design**. This means repeat revenues for the Group.

### Low capital requirements and carbon emissions

Most customised products are **created for specific projects**, which tend to be long-lasting and require a low volume and high mix, manual or semi-manual production model. The investment requirements and carbon footprint for such are relatively low.



Strategic Report

## MARKET REVIEW

### Sustainable growth market

We focus on four target markets, which account for 76% of Group revenue<sup>1</sup>: renewable energy, transportation, medical and industrial automation & connectivity. These are expected to drive the Group's organic revenue well ahead of GDP over the economic cycle.

Growth in these markets is driven by global macro trends, such as the need for renewable sources of energy, electrification of transportation systems, an ageing affluent population and expanding infrastructure.

Revenue from target markets<sup>1</sup> (% of total revenue)

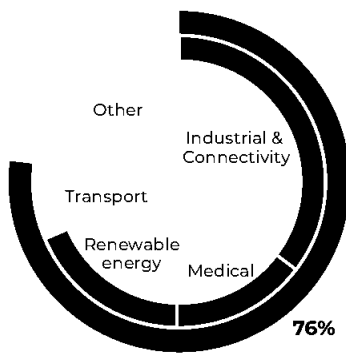

- Based on Group FY 2021/22 revenue of £379.2m
- UN SDGs United Nations Sustainable Development Goals
- International Energy Agency (IEA)
- Research and markets
- Research and markets
- Statistics

### Target markets



### Renewable Energy

Growth rate p.a.

2019-2030<sup>3</sup>

Mega trend

- Decarbonisation
- Energy source diversification

Market drivers

- Changing regulations & new standards
- Government initiatives

Technology integration

- Increasing scale of wind turbines
- Smart grid and energy efficient technology

discoverIE's solutions

- Power & Magnetics**
  - Liquid cooled power reactors and transformers for wind power systems
- Sensing & Detection**
  - Encoders in solar trackers to obtain reliable positioning of tilt and azimuth angles
  - Encoders for harsh environments in wind energy
- Connectors & Communications**
  - DC isolators and DC/AC power inverters for solar power

UN SDGs<sup>2</sup> Alignment





## Transportation

2021-2029<sup>e</sup>

- Vehicle Electrification
  - Smart transportation
- 
- Tightening emissions regulations
  - Mass-transit and route vehicles
  - Growing public awareness
  - 'Safety-centric' agenda
- 
- Sensing technology
  - Smart charging
  - High speed rail
  - Electrification of mass transit
- 
- Power & Magnetics**
- Traction transformers for railway rolling stock applications
  - E-Mobility charging infrastructure (EV, eBus, Marine, & heavy duty vehicles)
- Control Systems & Displays**
- Ruggedised CPU modules and carrier boards for automatic guided vehicles
  - Ruggedised HMI devices with antivibration technology and waterproof sealing for marine applications
  - Master controllers for trains
- Sensing & Detections**
- Torque, load and force sensors for aircraft braking systems, actuation systems and in flight controls
- Connectors & Communications**
- Battery isolation switches for trains
  - CCTV for public transportation



## Medical

2021-2030<sup>f</sup>

- Sensing, analytics and artificial intelligence
- 
- Rising life expectancy and growing middle class population
  - Growing geriatric population
  - Increasing use of radiation therapy in diagnosis and treatment
- 
- Artificial intelligence & machine learning
  - Sensing and analytics
  - Automation and robotics
- 
- Power & Magnetics**
- Built-in transformers and inductors for MRI scanners
- Control Systems & Displays**
- Trackballs for ultrasound systems
  - Panel PCs for blood pressure diagnostics
  - Single board computers for electro cardiographs
  - Optical implants for restoring vision to the visually impaired
- Sensing & Detections**
- Pressure sensors in oxygen tanks and thermal compression units
  - Cable extension transducers for use in oncology machines and MRI machines
  - X-ray detectors for bone density measuring and X-ray scans
- Connectors & Communications**
- Anti-microbial and sterilisable cables for medical equipment



## Industrial and Connectivity

2021-2029<sup>f</sup>

- Industrial automation
  - Connectivity
  - Internet of Things
- 
- Proliferation of smart devices
  - Next generation wireless technology
  - 'Big data'
- 
- Automation and robotics
  - Smart factories
  - Artificial intelligence
  - 5G technology
- 
- Power & Magnetics**
- Transformers for process machines and robotics
- Control Systems & Displays**
- Control systems for industrial robotic applications
  - Smart control panels for indoor climate control
- Sensing & Detections**
- Light detectors for harmful gas emissions
  - Linear & rotary potentiometers for steering systems and throttle position in engines of agricultural vehicles
- Connectors & Communications**
- Wireless antennas for robotic control
  - Fibre optics connectors
  - Circuit breakers for ships



## OUR STRATEGY



**“We have pursued a clear strategy that focuses on structural growth markets.”**

**Nick Jefferies**  
Group Chief Executive

### Our strategic aim

Our mission is to grow our business in customised electronics by focusing on markets with sustained growth prospects, driven by increasing electronic content and where there is an essential need for our products.

We aim to achieve this through a motivated, entrepreneurial and empowered workforce that adheres to the highest ethical and quality standards.

### Our strategic priorities

Over the years, we have pursued a clear strategy, investing in initiatives that enhance design opportunities for customised products and targeting structural growth markets. Following the sale of the Custom Supply distribution business, we now focus purely on design and manufacture opportunities.

Our strategy has four strategic priorities:



**Grow sales well ahead of GDP**



**Move up the value chain**



**Acquire high quality businesses**



**Further internationalise**

### Impact of climate change

Our initial assessments of various CO<sub>2</sub> emission concentration pathway scenarios have shown that we are exposed to certain risks in the transition to a low carbon economy, such as:

- Higher prices of raw materials, such as copper and aluminium, driven by policy changes
- Production disruptions as a result of power and labour shortages

However, the commercial opportunities presented outweigh such risks, and our business model and strategic focus on our target markets are well suited to capture these opportunities, such as:

- Increasing demand for renewable energy, especially wind and solar, in which we already have an established position
- Increasing demand for electric vehicles and related infrastructure drives higher demand for electrical and electronic components

See pages 46 to 50 for a summary of our climate-related risks and opportunities and our TCFD Report on pages 67 to 69 for more detail.

Further analysis is ongoing to quantify such potential impacts and we will report our findings in due course.

Strategic priorities	Progress to date	Link to key strategic indicators	Link to risks
<p><b>Grow sales well ahead of GDP</b> over the economic cycle by focusing on structural growth markets, namely renewable energy, transportation, medical and industrial &amp; connectivity. Each of these markets is predicted to grow faster than global GDP, at 7-12% p.a.</p>	<p>The Group has delivered on average 7% annual organic growth since FY 2014. Target markets have grown well ahead of wider markets, even during the pandemic. Sales into the target markets as a proportion of the Group sales have increased from 56% in FY 2017 to 76% in FY 2022. We aim to achieve 85% sales from target markets by FY 2025.</p>	<p><b>B C</b></p>	<p><b>1 4 5 7 8</b></p>
<p><b>Move up the value chain</b> where operating margins are higher. We aim to achieve this by leveraging synergies amongst our business units, improving efficiency and through acquisitions.</p>	<p>The Group's underlying operating margin has tripled since FY 2014 to 10.9% in FY 2022. This was achieved primarily by disposing of the lower margin Custom Supply distribution business, as well as operational leverage.</p>	<p><b>A</b></p>	<p><b>2 4 5 6 7</b></p>
<p><b>Acquire high quality businesses</b> with attractive growth prospects and strong, sustainable margins. In a fragmented market, opportunities exist to consolidate certain manufacturers of customised products for the Group's common customer base. We have a clear approach to acquisitions and the target businesses must have the discoverIE DNA.</p>	<p>The Group has acquired 19 design and manufacturing businesses in the past ten years, investing a total of £350m. The businesses that joined the Group more than two years ago have delivered a return on investment of 14% on average.</p>	<p><b>A B C D</b></p>	<p><b>1 2</b></p>
<p><b>Further internationalise</b> the business by expanding in North America and Asia. Having started as a British business, the Group has established a strong footprint in Europe over the years. We are expanding our operations in North America and Asia where demands for our products are growing fast.</p>	<p>We have grown sales for our design and manufacture business outside Europe from 5% of total Group sales in FY 2014 to 40% in FY 2022 through a combination of organic expansion and acquisitions.</p>	<p><b>B</b></p>	<p><b>1 2 7</b></p>

### Key strategic indicators

- A** Increase underlying operating margin
- B** Build sales beyond Europe
- C** Increase target market sales
- D** Reduce carbon emissions

### Risks

- 1** Instability in the economic environment
- 2** Business acquisitions underperformance
- 4** Loss of major customers
- 5** Loss of major suppliers
- 6** Technological changes
- 7** Major business disruption
- 8** Cyber security



Strategic Report

# OUR STRATEGY IN ACTION

## Noratel Group

Investing in growth

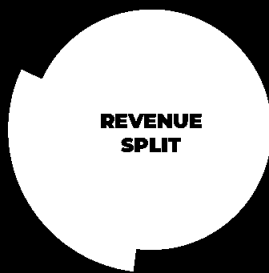

- Renewable energy
- Transportation
- Medical
- Industrial & Connectivity
- Other

Having joined discoverIE Group in July 2014, Noratel is a global designer and manufacturer of electromagnetic components, specifically medium and high power transformers and chokes.

In the eight years since acquisition, we have provided Noratel with strategic guidance, focusing on organic growth in our four target markets. We have also invested to support the business' growth plan in Asia and North America, including:

- Upscaled production facilities, including a new manufacturing facility in India
- Rationalised manufacturing facilities in North America
- Strengthened its finance team
- Added two bolt-on acquisitions – Plitron and Hobart - to strengthen its position in North America
- Optimised working capital

As a result, the business achieved revenue growth of 9% p.a. between FY 2014/15 and FY 2021/22, now with 75% of its revenue from target markets, compared with 62% in FY 2015. Sales outside Europe increased from 28% to 47%, and operating margin improved by 4% over the eight years.

Today, Noratel, with 2,600 employees, has grown into a leading electromagnetic components supplier to all major producers of wind systems.



### Impact from operations:



### Impact from products:





# MTC Go Green



MTC Micro Tech Components was one of the Group's early acquisitions. MTC manufactures and supplies electromagnetic shielding products, serving primarily the European and Asian industrial electronic market.

Having become a member of the discoverIE Group in 2011, MTC has always been at the forefront of environmental management amongst the Group's operating businesses. For instance, it was the first to achieve ISO14001 Environmental Management System accreditation. Over the years, it has implemented energy saving measures, such as introducing smart meters, at its facilities in Germany and South Korea, as well as encouraging behavioural changes amongst its workforce.

Moreover, it has developed new products that are more eco-friendly, such as halogen-free EMI shielding gaskets. In 2019, MTC launched the "MTC GO GREEN" initiative, replacing all packaging, such as bubble wrap and plastic fillings, with recyclable materials, which were converted from old cardboard packaging.

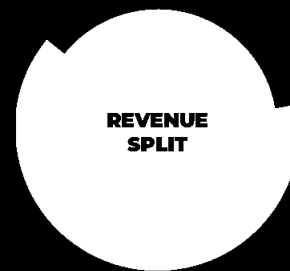

- Renewable energy
- Transportation
- Medical
- Industrial & Connectivity
- Other

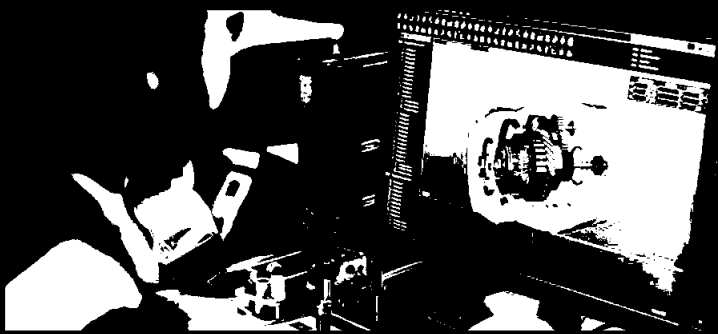

### Impact from operations:



### Impact from products:



Strategic Report

## OUR STRATEGY IN ACTION

# Acquisition of Antenova

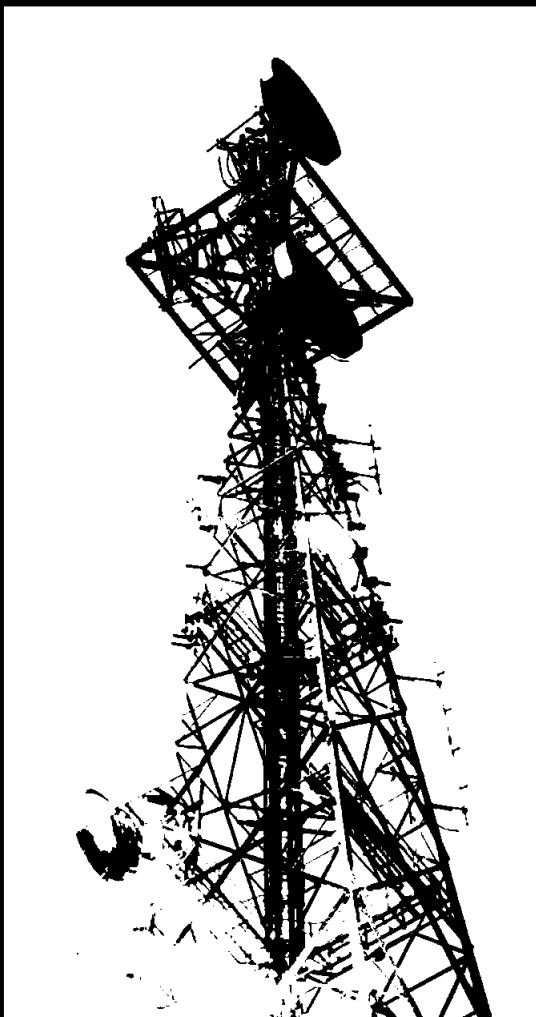

Headquartered in the UK with an R&D centre in Taiwan, Antenova designs and manufactures a range of antennas for the internet of things ("IoT"), particularly industrial connectivity applications. Typical applications are vehicle telematics trackers, medical monitoring systems, EV charging systems and smart grids. Antennas play an essential part in industrial automation and smart city infrastructure.

discoverIE acquired Antenova in August 2021 for a cash consideration of £18.2m on a debt free, cash free basis. Antenova was expected to generate c. £8.0m sales and £2.2m underlying operating profit in 2021. It is now part of the Sensing & Connectivity division.

Impact from products:

9 INDUSTRY INNOVATION  
AND INFRASTRUCTURE



11 SUSTAINABLE CITIES  
AND COMMUNITIES



# Acquisition of Beacon EmbeddedWorks

Beacon EmbeddedWorks is a Minneapolis, US-based designer, manufacturer and supplier of custom System-on-Module ("SOM") embedded computing boards and related software, supplying the medical, industrial and aerospace & defence markets in the US. SOMs are miniature circuit boards that integrate system functions into a single, compact module, offering the functionality of a computer in a package that is highly versatile.

Beacon EmbeddedWorks' award-winning SOMs are designed for long product lifecycles and extreme conditions, enabling customers to have complete customisation and accelerate their product development.

In the year ended 31 December 2020, Beacon EmbeddedWorks delivered sales of \$28.1m and an underlying operating profit of \$5.9m. The acquisition has expanded the Group's international footprint significantly in North America.

discoverIE acquired Beacon EmbeddedWorks in September 2021 for a cash consideration of \$80.5m on a debt free, cash free basis. It is now part of the Magnetics & Controls division.



A SOM solution developed for a groundbreaking implantable medical device that delivers useful artificial vision for patients with retinitis pigmentosa.

## Impact from products:



## Strategic Report

# KEY STRATEGIC INDICATORS

### (A) Increase underlying operating margin

FY25 Target

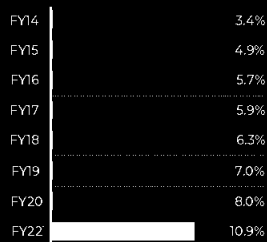

Underlying operating profits as a percentage of sales.

Underlying operating margin exceeded 10% for the first time with 8.0% reported in FY 2019/20 and 7.7% in FY 2020/21 as a business including Custom Supply. The Group benefited both from the strong organic sales growth delivered during the year and the exit from the lower margin distribution business. With this exit, the FY 2024/25 margin target was increased during the year to 13.5% (previously 12.5%).

### (B) Build sales beyond Europe<sup>2</sup>

FY25 Target

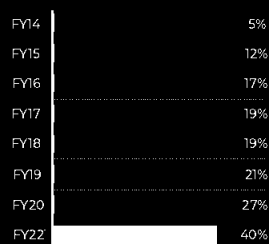

Sales in the Americas, Asia and Africa. Excludes the UK and Europe.

Sales beyond Europe in the year increased by 13ppts to 40% of Group revenue from 27% two years ago (and 28% last year) driven by three factors. Firstly, the exit from distribution which was a UK/European focused business (c.7ppts increase), secondly, the five acquisitions in the last 18 months in particular Beacon, Phoenix and CPI which are all US based (c.3ppts); thirdly, organic growth during the year was strongest in Asia and North America (c.3ppts). Accordingly the target for FY 2024/25 was increased during the year to 45% (previously 40%).

### (C) Increase target market sales<sup>2</sup>

FY25 Target



The proportion of Group revenue that is derived from sales into our target markets.

Target market sales in the year increased by 8ppts to 76% of Group revenue from 68% two years ago (and 70% last year) of which 5ppts reflects the exit from the distribution businesses. A further 5ppts improvement has been delivered through a combination of organic growth being more weighted to these long-term structural growth markets with a 2ppts reduction from the five acquisitions in the last 18 months which, while well aligned with these markets, are currently below our average rate. The FY 2024/25 target remains as 85% of sales from target markets.

### (D) Reduce carbon emissions

FY25 Target



The proportionate reduction in carbon emissions intensity from the Group's operations from the 2019 base year (measured on a tCO<sub>2</sub>e / £m revenue basis).

A new target was introduced in November 2020 for the reduction of carbon emissions from the Group's existing businesses by 50% over five years. Additionally, for new acquisitions, we are targeting that within the first five years of ownership, at least 50% of their energy demand is generated from renewable sources. For calendar year 2021, carbon emissions reduced by 30% on a like-for-like basis (calendar year 2020: 6% like-for-like reduction). During this year, capital has been invested in projects to reduce carbon emissions by switching to clean energy, including solar panel installations in Sri Lanka, and an air source heat pump in Poland, two of the Group's major manufacturing facilities.

Continuing operations. FY 2021/22 shown as growth over the pre-Covid period FY 2019/20 as this reflects the actual ongoing growth of the business. FY 2013/14 to FY 2019/20 are for total operations before disposals, as reported at the time.

<sup>2</sup> As a percentage of Group revenue.

<sup>3</sup> The reported figure was 19.23% reduction in 2020. It was reduced to 6% after adjusting for the effects of Covid to provide an underlying measure.

## KEY PERFORMANCE INDICATORS

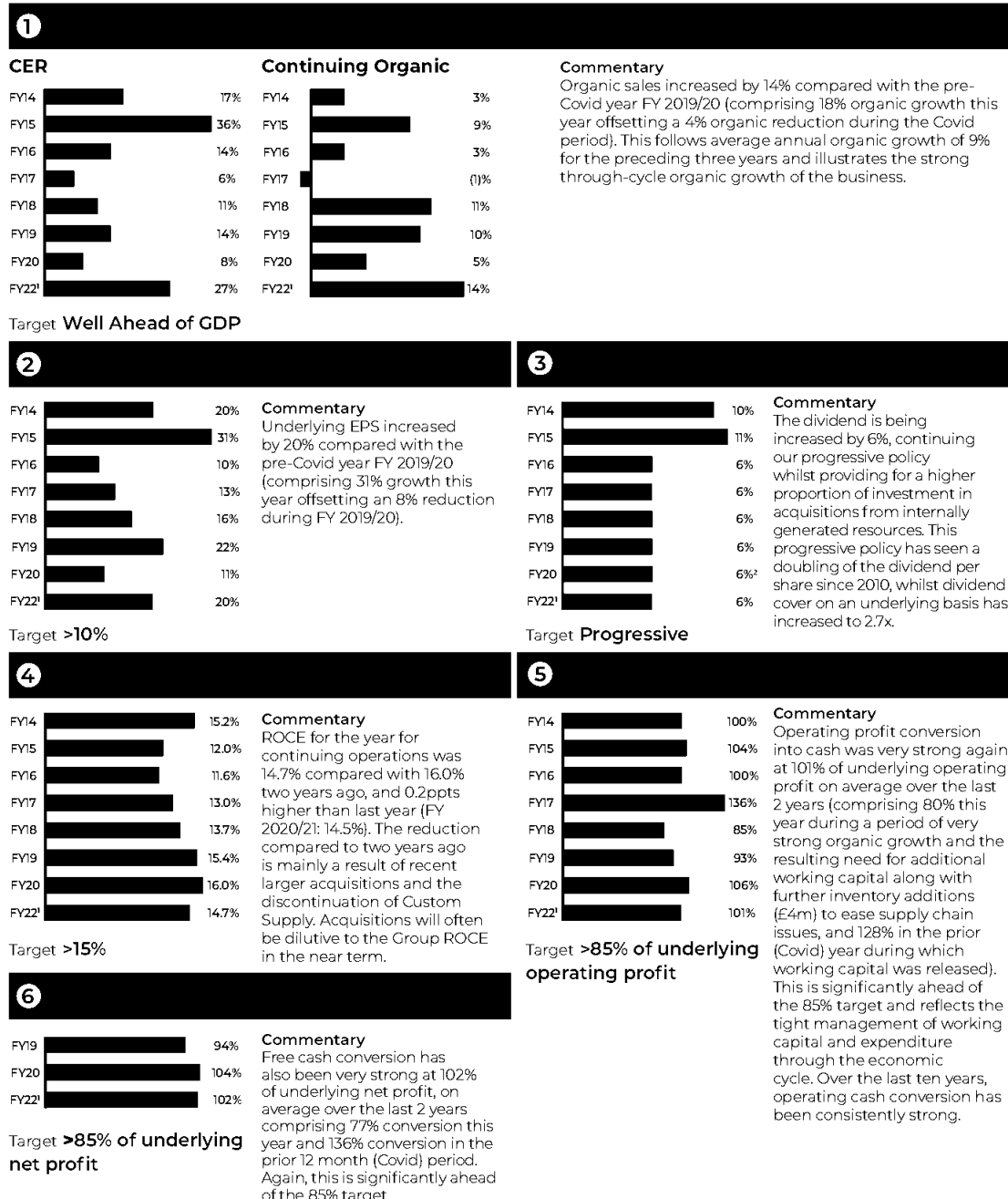

<sup>1</sup> Continuing operations. FY 2021/22 shown as growth over the pre-Covid period FY 2019/20 as this reflects the actual ongoing growth of the business. FY 2013/14 to FY 2019/20 are for total operations before disposals as reported at the time.  
<sup>2</sup> 6% increase in the H1 2019/20 interim dividend; a final dividend was not proposed for FY 2019/20 due to Covid.  
<sup>3</sup> Defined in note 2 of the Group financial statements.

## STRATEGIC AND OPERATIONAL REVIEW

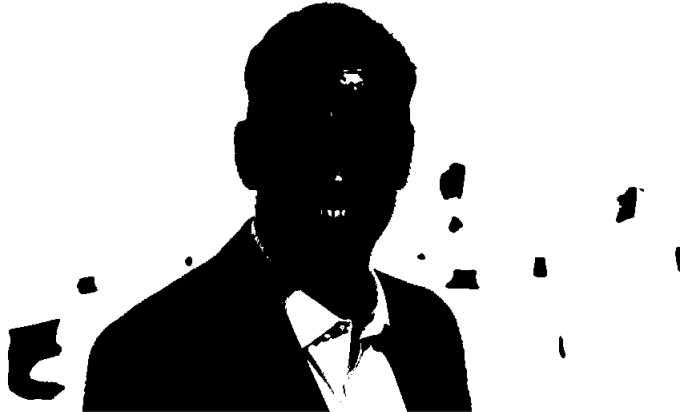

**“The Group has performed strongly and is well positioned in a rapidly changing environment, proving both resilient and flexible”**

**Nick Jefferies**  
Group Chief Executive

### Overview

The Group had a strong year delivering record organic growth building on the progress made in the Covid-impacted prior year, and the pre-Covid period two years ago. Since FY 2017/18 as the customised design and manufacturing strategy gathered momentum, ongoing Group organic sales have grown by 10% CAGR while underlying EPS has grown by 26% CAGR.

With the exit this year from the lower margin business of electronic distribution, discoverIE is now solely focused on the design and manufacture of customised and niche, innovative electronics. Five higher margin acquisitions have been made over the last 18 months (three during the year), further progressing us towards our medium-term goals of becoming a higher margin Group, focused on international and sustainably-aligned target markets, generating strong cash flows. Our low gearing leaves us with considerable headroom for further acquisitions.

Continuing Group sales for the year increased by 28% at CER, being 18% higher organically than last year and 14% higher

organically than the pre-Covid period two years ago. Performance in our target markets, which now account for 76% of Group sales, continues to be strong, helping to deliver an underlying operating margin of 10.9%, up 3.2ppts since last year and up 0.7ppts on a continuing basis.

Orders grew by 36% organically compared with last year and by 32% compared with two years ago following the build-up of a strong pipeline of design wins over several years. This resulted in a record order book of £224m, respectively 62% and 71% higher organically than last year and two years previously. Whilst over 80% of the order book is for delivery within twelve months from the time of order, we have seen customers continue to place longer term orders. Over the course of the new financial year, we expect the order book level to normalise as it converts into sales.

The agility of the Group’s model and the capabilities of our employees have enabled our businesses to respond effectively to the operational challenges caused by Covid and ongoing

supply chain headwinds, including semiconductor shortages which delayed sales in the second half of the year in two of our 20 businesses.

### Positioned well in a changing world

The Group is well positioned in an environment of rapidly changing global events and conditions, proving both resilient and flexible.

With 30 manufacturing sites and operations around the world supplying international and multinational customers, the Group is responding quickly to the growing trend of customers localising production, both for risk mitigation and environmental reasons. Additionally, with our manufacturing using only a low proportion of bought-in components, the majority being manufactured in-house from raw materials, our exposure to external supply chain restrictions is reduced (but not eliminated).

Gross margins have been robust despite supply chain headwinds and inflationary pressures. The Group’s products are essential components, amounting to a small proportion of a customer’s system cost, and sustain resilient margins.



The Group operates a capital-light business model focused on organic growth, operating efficiencies and high quality, accretive acquisitions. Selling into high quality markets with long term growth prospects, the Group expects to continue to grow ahead of the wider industry, converting revenue growth into profits and earnings into cash. Since 2017/18, organic sales from continuing operations have grown by 10% CAGR, approximately double that of global industrial production growth, with underlying operating profit growing by 34% CAGR and underlying earnings per share by 26% CAGR. Over the same period, conversion of operating profits into operating cash flow exceeded 100% p.a. on average.

Creating a sustainable business is one of the Group's top priorities. As detailed further below, actions to halve our like-for-like carbon emissions are underway and making good progress. More widely, our Group ESG priorities have been established with detailed plans and targets set.

### Group Strategy

The Group designs and manufactures customised and niche electronic components, operating internationally and focusing on structurally growing markets that are driven by increasing electronic content and where there is an essential need for our products. With our target markets and global customer base, the business is expanding both in Europe and beyond, with 40% of continuing Group sales being outside Europe, as we build a geographically diverse electronics group.

The continuing Group has been built through organic growth, operational efficiency and 19 carefully selected and integrated acquisitions over the past 11 years to create a specialist, high margin design and manufacturing business. We have a well-developed approach to acquisitions and the use of capital, and see significant scope for further expansion of the Group with a number of opportunities in development.

The Group's strategy comprises four elements:

1. Grow sales well ahead of GDP over the economic cycle by focussing on the structural growth markets that form our sustainable target markets;
2. Move up the value chain into higher margin products;
3. Acquire businesses with attractive growth prospects and strong operating margins;
4. Further internationalise the business by developing operations in North America and Asia.

These elements are underpinned by core objectives of generating strong cash flows from a capital-light business model, and delivering long-term sustainable returns while reducing our impact on the environment.

### Sustainability and our positive impact

The Group's purpose aligns with the United Nations' Sustainability Development Goals ("UN SDGs"). We create a positive impact on the world around us and people's lives through both our products and our operations. By creating innovative electronics and focusing on four target markets, we play an essential role in contributing to the following UN SDGs:

- **SDG3** – Ensure healthy lives and promote well-being for all ages
- **SDG7** – Ensure access to affordable, reliable, sustainable and modern energy for all
- **SDG9** – Build resilient infrastructure, promote inclusive and sustainable industrialisation and foster innovation
- **SDG11** – Make cities and human settlements inclusive, safe, resilient and sustainable
- **SDG13** – Take urgent action to combat climate change and its impact

Please see pages 60 to 74 for our Sustainability Report, which outlines the progress we have made.



## Strategic Report

# STRATEGIC AND OPERATIONAL REVIEW

### Target Markets – Aligned with structurally growing, sustainable markets

With global GDP expected to grow by around 4% CAGR 2020–26 (Source: Statista) and global industrial production forecast to also grow by around 4% in 2022, discoverIE continues to focus on its four target markets which are expected to grow at higher rates than other industrial markets: renewable energy, medical, electrification of transportation, and industrial automation & connectivity. Together they account for 76% of continuing Group sales.

For the Group, these markets continue to show above average revenue growth. Over the last five years, continuing Group organic sales have grown by 10% CAGR with target market sales growing by 12% CAGR while non-target markets have grown by 6% CAGR.

Growth in these target markets is driven by increasing electronic content and by global mega trends such as the accelerating need for renewable sources of energy, an ageing affluent population, vehicle electrification and industrial automation.

#### i) Renewable Energy Mega trend – decarbonisation and diversification of energy sources

The world's drive towards net zero will require a global shift towards electricity as a main source of power and the majority of new electricity capacity is expected to come from solar and wind. The International Energy Agency ("IEA") estimates that demand for global electricity will need to double to achieve net zero by 2050 and expects that the share of renewables in electricity generation will increase from 29% in 2020 to

60% in 2030 and as high as 90% by 2050. Shorter-term, the IEA predicts that renewables will account for up to 95% of the global increase in power capacity between 2020 and 2026 with solar alone accounting for half the growth. The growth in solar and wind energy is partially driven by the fall in costs: research by the World Resources Institute has shown that the cost of solar photovoltaic electricity has fallen by 85% since 2010; the cost of both onshore and offshore wind electricity has halved during the same period.

#### ii) Medical Mega trend – sensing, analytics and artificial intelligence

Growth in the global medical and healthcare markets is driven by the rise in chronic diseases, a growing geriatric population, rising disposable income and improved access to healthcare facilities. Moreover, the use of electronic content is increasing as a result of the proliferation of digital technologies and the rising adoption of electronic devices for rapid and enhanced patient care diagnostics as well as the rise in minimal-invasive surgeries and non-invasive diagnostic devices.

The medical electronics market is expected to maintain its above-average growth, with Precedence Research predicting a global market growth of 11.8% CAGR for 2021–2030.

#### iii) Transportation Mega trend – smart transportation, vehicle electrification

Safety, efficiency and environmental impact are key trends driving the rise in electronic content in the global transport market with improving technology and falling costs leading the growing demand for electronics.

The Group continues to focus on niche applications, especially in rail, bus and delivery vehicles, together with the growing demand for interconnectivity of the transport infrastructure and the emergence of smart cities.

Data Bridge Research estimates that the smart transportation market will grow at 11.1% CAGR from 2021–2029, whilst Research and Markets predicts CAGR growth of nearly 20% in the global electronic connectivity in the transportation market between 2021 and 2030.

#### iv) Industrial Automation & Connectivity Mega trend – growth in robotics, industrial automation and connectivity

The market for autonomous mobile robots is expanding rapidly across multiple sectors of industry such as warehousing, aviation, medicine and healthcare, and farming.

Furthermore, the increasing adoption of the internet of things ("IoT") and artificial intelligence ("AI"), the rising awareness of safety and security as well as the increasing demand for predictive maintenance and efficient supply chain management is driving the underlying growth of global industrial IoT markets. Fortune Business Insights predicts an average growth of 9.8% from 2021 to 2029 in the global industrial automation market, and Statista expects growth of as much as 22.8% CAGR in the global industrial IoT market during 2021 – 2028.

With a focus on sustainable markets, the Group continues to concentrate on improving efficiency in industrial market applications that are aligned with a sustainable growth agenda, including fibre optic and wireless connectivity applications.

Examples of new and emerging applications include areas in smart agriculture such as pollination and crop management.

### Engineering-led Sales Model

Our business model has three core capabilities:

- **Engineering** – our primary and leading differentiator. By understanding our customers' design challenges we design and create products that address their specific needs.
- **Manufacturing** – we manufacture individually designed products to a repeatedly and consistently high standard at one or more of our production facilities internationally.
- **Logistics** – we supply our products internationally to customers' various production locations over the life of their demand, typically for five to seven years.

We apply these capabilities to develop long term, embedded relationships with our customers as follows:

- **Understanding customer needs**  
By listening to and understanding customers' needs, we help solve their technical challenges to create more effective, efficient, productive and sustainable equipment and comply with increasingly stringent environmental, health, safety and performance requirements.
- **Enduring customer relationships**  
Our sales model creates a unique understanding of customers' needs and builds long term relationships that last for many years.
- **Engineering-led solutions**  
By applying our extensive technical knowledge of applications and design, our engineers create unique products for customers' specific needs.

### Recurring revenues

Our designs are specified into our customers' system designs, leading to multiple years of repeated monthly demand and creating stable, recurring revenue streams.

### Regional manufacturing

Manufacturing locations in Europe, Asia and North America provide regional supply for customers, reducing transit times, costs and environmental impact as well as providing flexibility and reducing risk of disruption.

Additionally, we acquire businesses with similar characteristics, building our product capability and international presence. With many customers operating internationally, it is necessary for us to have a presence in multiple regions of the world and with the market being highly fragmented, numerous opportunities exist for us to acquire complementary businesses.



## Strategic Report

# STRATEGIC AND OPERATIONAL REVIEW

### Key Strategic and Performance Indicators

Since 2014, the Group's progress with its strategic objectives and its financial performance has been measured through key strategic indicators ("KSIs") and key performance indicators ("KPIs"). The KSI targets have been raised as they are achieved, and in November 2021 the targets were raised again following the announced exit from the distribution businesses. For tracking purposes, the KSIs and KPIs in the table below remain as reported at the time rather than adjusted for disposals. Given the one-off impact of Covid in FY 2020/21, we have shown in the tables below this year's growth for both KSIs and KPIs relative to the pre-Covid period two years ago (FY 2019/20) to illustrate the development of the Group. This year's growth relative to both FY2019/20 and FY 2020/21 is discussed below.

### Key Strategic Indicators

	FY14	FY15	FY16	FY17	FY18	FY19	FY20	FY22 <sup>1</sup>	FY25 Targets
1. Increase underlying operating margin	3.4%	4.9%	5.7%	5.9%	6.3%	7.0%	8.0%	10.9%	13.5%
2. Build sales beyond Europe <sup>2</sup>	5%	12%	17%	19%	19%	21%	27%	40%	45%
3. Increase target market sales <sup>2</sup>				56%	62%	66%	68%	76%	85%
4. Carbon emissions reduction							6% <sup>3</sup>	33%	50%

<sup>1</sup> Continuing operations. FY 2021/22 shown as growth over the pre-Covid period FY 2019/20 as this reflect the actual ongoing growth of the business. FY 2013/14 to FY 2019/20 are for total operations before disposals, as reported at the time.

<sup>2</sup> As a percentage of Group revenue.

<sup>3</sup> First test was CY20 compared to CY19.

The Group made further significant progress with its KSIs during this year. Alongside strong organic growth, the exit from distribution has resulted in a positive step change in the KSIs, which is explained as follows:

- Underlying operating margin exceeded 10% for the first time and follows 8.0% reported in FY 2019/20 and 7.7% in FY 2020/21 when the business included Custom Supply. The Group benefited both from the strong organic sales growth delivered during the year and the exit from the lower margin distribution business. With this exit, the FY 2024/25 margin target was increased during the year to 13.5% (previously 12.5%).
- Sales beyond Europe in the year increased by 13ppts to 40% of Group revenue from 27% two years ago (and 28% last year) driven by three factors. Firstly, the exit from distribution which was a UK/European focused

business (c.7ppts increase); secondly, the five acquisitions in the last 18 months in particular Beacon, Phoenix and CPI which are all US based (c.3ppts); thirdly, organic growth during the year was strongest in Asia and North America (c.3ppts). Accordingly the target for FY 2024/25 was increased during the year to 45% (previously 40%).

- Target market sales in the year increased by 8ppts to 76% of Group revenue from 68% two years ago (and 70% last year) of which 5ppts reflects the exit from the distribution businesses. A further 5ppts improvement has been delivered through a combination of organic growth being more weighted to these long-term structural growth markets with a 2ppts reduction from the five acquisitions in the last 18 months which, while well aligned with these markets, are currently below our average rate. The FY 2024/25 target

remains as 85% of sales from target markets.

- A new target was introduced in November 2020 for the reduction of carbon emissions intensity from the Group's existing businesses by 50% over five years. Additionally, for new acquisitions, we are targeting that within the first five years of ownership, at least 50% of their energy demand is generated from renewable sources. For calendar year 2021, carbon emissions reduced by 33% on a like-for-like basis (calendar year 2020: 6% like-for-like reduction). During this year, capital has been invested in projects to reduce carbon emissions by switching to clean energy, including solar panel installations in Sri Lanka, and an air source heat pump in Poland, two of the Group's major manufacturing facilities.



## Key Performance Indicators

	FY14	FY15	FY16	FY17	FY18	FY19	FY20	FY22 <sup>1</sup>	FY25 Targets
1. Sales growth									
CER	17%	36%	14%	6%	11%	14%	8%	27%	Well ahead of GDP
Continuing organic	3%	9%	3%	(1%)	11%	10%	5%	14%	
2. Underlying EPS growth	20%	31%	10%	13%	16%	22%	11%	20%	>10%
3. Dividend growth	10%	11%	6%	6%	6%	6%	6% <sup>2</sup>	6%	Progressive
4. ROCE <sup>3</sup>	15.2%	12.0%	11.6%	13.0%	13.7%	15.4%	16.0%	14.7%	>15%
5. Operating profit conversion <sup>3</sup>	100%	104%	100%	136%	85%	93%	106%	101%	>85% of underlying operating profit
6. Free cash conversion <sup>3</sup>						94%	104%	102%	>85% of underlying net profit

<sup>1</sup> Continuing operations. FY 2021/22 shown as growth over the pre-Covid period FY 2019/20 as this reflects the actual ongoing growth of the business. FY 2013/14 to FY 2019/20 are for total operations before disposals as reported at the time.

<sup>2</sup> 6% increase in the H1 2019/20 interim dividend; a final dividend was not proposed for FY 2019/20 due to Covid

<sup>3</sup> Defined in note 2 of the Group financial statements

The Group also made further significant progress with its KPIs during the year. Given the one-off impact of Covid last year, this year's growth is shown relative to the pre-Covid period FY 2019/20 illustrating the development of the Group. This year's growth relative to both FY 2019/20 and FY 2020/21 is discussed below.

The performance of each of our Group KPIs for this year are as follows:

- Organic sales increased by 14% compared with the pre-Covid year FY 2019/20 (comprising 18% organic growth this year offsetting a 4% organic reduction during the Covid period). This follows average annual organic growth of 9% for the preceding three years and illustrates the strong through-cycle organic growth of the business.
- Underlying EPS increased by 20% compared with the pre-Covid year FY 2019/20 (comprising 31% growth this year offsetting an 8% reduction during FY 2019/20).

- The dividend is being increased by 6%, continuing our progressive policy whilst providing for a higher proportion of investment in acquisitions from internally generated resources. This progressive policy has seen a doubling of the dividend per share since 2010, whilst dividend cover on an underlying basis has increased to 2.7x.
- ROCE for the year for continuing operations was 14.7% compared with 16.0% two years ago, and 0.2ppts higher than last year (FY 2020/21: 14.5%). The reduction compared to two years ago is mainly a result of recent larger acquisitions and the discontinuation of Custom Supply. Acquisitions will often be dilutive to the Group ROCE in the near term.
- Operating profit conversion into cash was very strong again at 101% of underlying operating profit on average over the last

- 2 years (comprising 80% this year during a period of very strong organic growth and the resulting need for additional working capital along with further inventory additions (£4m) to ease supply chain issues, and 128% in the prior (Covid) year during which working capital was released). This is significantly ahead of the 85% target and reflects the tight management of working capital and expenditure through the economic cycle. Over the last ten years, operating cash conversion has been consistently strong.
- Free cash conversion has also been very strong at 102% of underlying net profit, on average over the last 2 years comprising 77% conversion this year and 136% conversion in the prior 12 month (Covid) period. Again, this is significantly ahead of the 85% target.



## Strategic Report

# STRATEGIC AND OPERATIONAL REVIEW

### Divisional Results

Following the Group's exit from distribution, the Custom Supply division has been treated as discontinued operations, with the Design & Manufacturing ("D&M") division housing all of the Group's ongoing operating businesses. Reflecting this development and in line with certain growth initiatives, during the final quarter, the Group arranged the D&M division into two operating segments, the Magnetics & Controls division ("M&C") and the Sensing & Connectivity division ("S&C").

This new structure, which aligns business units by technology area, will enable greater collaboration between business units, improve visibility for the Group's growth initiatives and increases management bandwidth for further growth. Both divisions have similar exposure to the Group's target markets and geographies. The management and structure of each business unit is unchanged.

The divisional results for the continuing Group for the year ended 31 March 2022 are set out and reviewed below.

	FY 2021/22			FY 2020/21			Reported revenue growth	Organic revenue growth	Organic order growth
	Revenue £m	Underlying operating profit <sup>1</sup> £m	Margin	Revenue £m	Underlying operating profit <sup>1</sup> £m	Margin			
M&C	234.7	29.8	12.7%	190.4	23.4	12.3%	23%	22%	36%
S&C	144.5	23.3	16.1%	112.4	15.5	13.8	29%	11%	36%
Unallocated		(11.7)			(8.1)				
<b>Total</b>	<b>379.2</b>	<b>41.4</b>	<b>10.9%</b>	<b>302.8</b>	<b>30.8</b>	<b>10.2%</b>	<b>25%</b>	<b>18%</b>	<b>36%</b>

<sup>1</sup> Underlying operating profit excludes acquisition-related costs and results of discontinued operations

### Magnetics & Controls Division ("M&C")

The M&C division designs, manufactures and supplies highly differentiated magnetic and power components, embedded computing and interface controls for industrial applications operating across 16 countries. The great majority of the products are manufactured in-house at one of the division's 20 manufacturing facilities, with its principal ones being in China, India, Mexico, Poland, Sri Lanka, Thailand, the US and the UK. Geographically, 6% of sales are in the UK, 49% in rest of Europe, 17% in North America and 28% in Asia.

During the year, the Group's production facilities established new normal ways of operating after the disruption of Covid and the Group's production capacity has returned to output capacity levels capable of satisfying strong sales growth rates.

To meet future growth, capacity is being expanded in the US and India, and production began as scheduled at the Group's new larger facility in Nogales, Mexico.

Orders were very strong in the year, increasing by 36% organically to £280.0m with a book to bill ratio of 1.19:1 (FY 2020/21: 1.06:1). The strong order performance led to sales increasing organically by 22% with strong organic growth across all regions: Asia growing organically by 30% driven by very strong organic growth in India, North America 28% and Europe & UK by 17%.

Combined with a 5% sales increase from acquisitions, overall sales increased by 27% CER. Including the impact of translation from a stronger Sterling on average, reported divisional revenue increased by 23% to £234.7m (FY 2020/21: £190.4m). This was achieved despite ongoing supply chain headwinds, in particular

semiconductor shortages which have delayed sales in two businesses within the division.

Underlying operating profit of £29.8m was £6.8m (+29%) higher than last year at CER and £6.4m (+27%) higher on a reported basis (FY 2020/21: £23.4m) with an underlying operating margin of 12.7%, 0.4ppts higher than last year (FY 2020/21: 12.3%) reflecting the positive effect of organic growth. Gross margin reduced slightly as delays to semiconductor supplies temporarily reduced volume throughput.

### Sensing & Connectivity Division ("S&C")

The S&C division designs, manufactures and supplies highly differentiated sensing and connectivity components for industrial applications through 12 businesses operating across nine countries. The vast majority of the products are manufactured in-house at one of the divisions 10

manufacturing facilities, with its principal ones being in Hungary, the Netherlands, Norway, Slovakia, the US and the UK. Geographically, 20% of sales are in the UK, 49% in Europe, 14% in North America and 17% in Asia.

As with the M&C division orders were very strong, increasing by 36% organically to £173.0m with a book to bill ratio of 1.20:1 (FY2020/21: 1.0:1). The strong order performance led to sales increasing organically by 11%, with 13% organic growth across Europe and 6% growth in Asia. Sales in North America were flat year-on-year due to the slower recovery of certain transport infrastructure projects and semiconductor supply delays.

Combined with a 20% sales increase from acquisitions, overall sales increased by 31% CER. Including the impact of translation from a stronger Sterling on average, reported divisional revenue increased by 29% to £144.5m (FY 2020/21: £112.4m). This was achieved despite a slower post Covid recovery in some of our UK based businesses.

Underlying operating profit of £23.3m was £7.9m (+51%) higher than last year at CER and £7.8m (+50%) higher on a reported basis (FY 2020/21: £15.5m) with an underlying operating margin of 16.1%, 2.3ppts higher than last year (FY 2020/21: 13.8%) reflecting the positive effect of organic growth coupled with higher margin acquisitions.

### Design Wins

Project design wins are a measurement of new business creation. By working with customers at an early stage in their project design cycle, opportunities are identified for our products to be specified into their designs,

which in turn lead to future recurring revenue streams.

The Group has a strong bank of design wins built up over several years that creates the basis for the growth in orders and sales now being experienced. During the year, design wins in the continuing business increased by 52% over the prior year and by 12% over the pre-Covid period two years ago. 86% of design wins were in the Group's target markets.

Additionally, during the year, new project design activity increased strongly, being broad based across all markets. The total pipeline of ongoing projects continues at a very high level.

### Acquisitions

The businesses we acquire are typically led by entrepreneurs who wish to remain following acquisition. We encourage this as it helps retain a decentralised, entrepreneurial and dynamic culture. The market is highly fragmented with many opportunities to acquire and consolidate.

We acquire businesses that are successful and profitable with good growth prospects and where we invest for growth and operational performance development. According to

the circumstances, we add value in some of or all of the following areas:

### Strategy, sales and products

- Developing the longer term strategy of the business;
- Internationalising sales channels and expanding the customer base, including via cross-selling initiatives and focusing sales development onto target market areas;
- Developing and expanding the product range;
- Developing and implementing sustainability initiatives.

### Talent management

- Investing in management capability ('scaling up') and succession planning;
- Peer networking and collaboration.

### Investment

- Capital investment in manufacturing and infrastructure;
- Improving manufacturing efficiency;
- Infrastructure efficiencies, such as warehousing and freight;
- Expansion through further acquisitions.





## Strategic Report

# STRATEGIC AND OPERATIONAL REVIEW

### Controls and support

- Implementing robust financial controls;
- Finance and related support, such as treasury, banking, legal, tax, insurance, consolidation.

During the year, the Group completed three acquisitions:

1. In May 2021, Control Products Inc ("CPI"), a US designer and manufacturer of custom, rugged sensors and switches, for \$11.4m (£8.1m) on a debt free, cash free basis.
2. In August 2021, Antenova, a UK designer and manufacturer of antennas and radio frequency (RF) modules for industrial connectivity applications, for £18.2m on a debt free, cash free basis.
3. In September 2021, Beacon EmbeddedWorks ("Beacon"), a US designer, manufacturer and supplier of custom System-on-Module (SOM) embedded computing boards and related software, principally supplying the medical and industrial markets in the US. Beacon was acquired for \$80.5m (£58.8m) on a debt free, cash free basis.

All three have retained their distinct brand identities and high-quality management. Their complementary product ranges and wider access to customers will create cross-selling opportunities in our target markets which are expected to drive further growth.

The Group has completed 19 acquisitions since 2011, contributing to growth in continuing Group revenues from £15m in FY 2012/13 to £379m this year. The Group's operating model is well established and has facilitated the smooth integration of acquired businesses. Through a combination of investment in

efficiency and leveraging of the broader Group's commercial infrastructure, the 14 businesses acquired since 2011 and owned for at least two years delivered a return on investment this year of 18.8%, an increase of 1.5ppts over last year (FY2020/21: 17.3% based on 13 acquisitions greater than 2 years old).

### Summary and Outlook

These results reflect the strength of the discoverIE business model which is performing well in good demand conditions and an inflationary environment and follows a resilient performance through the weaker Covid conditions of the year before. With record growth in orders, sales, order book and underlying earnings per share, which increased by 31%, continuing revenues and earnings are now well ahead of the pre-Covid period. I would like to thank all of our employees around the Group for their tremendous effort and flexibility over the last two years that has led to these results.

We are also making good progress on our sustainability initiatives. By switching our sites to renewable sources of energy where possible, the Group's like-for-like carbon emissions were 33% lower in calendar year 2021 than 2019 and we are on track to achieve our goal of a 50% reduction by 2025.

Following the Group's exit during the year from the business of distribution, discoverIE is now solely focused on the design and manufacture of customised electronics for industrial applications; our continuing focus is on achieving organic growth and new design wins in sustainable target markets, together with accretive acquisitions. The Group is well-funded, with a strong balance

sheet and cash flow, and has significant funding headroom for further acquisitions.

The new financial year has started well, with continued strong growth in organic sales, and the order book at record high levels. While supply chain headwinds and inflationary pressures remain, they are expected to be manageable.

With a clear strategy focused on long-term, high quality, structural and sustainable growth markets across Europe, North America and Asia, a diversified customer base, a record order book and a strong pipeline of acquisition opportunities, the Group is well positioned to make further good progress in the year ahead.

### Nick Jefferies

Group Chief Executive

14 June 2022



Strategic Report

## FINANCIAL REVIEW



**“Continuing Group underlying profit for the year was £41.4m, delivering an underlying operating margin of 10.9%.”**

**Simon Gibbins**  
Group Finance Director

### Revenue

Continuing Group sales of £379.2m were 18% higher organically than last year (FY 2020/21: £302.8m), and with acquired businesses (Phoenix and Limitor acquired last year, and CPI, Antenova and Beacon added this year) adding 10%, continuing sales increased by 28% CER. A stronger Sterling during the year, particularly compared with the US Dollar and Euro, reduced sales by 3% on translation for a net growth in reported continuing Group sales of 25%. Compared with two years ago, sales increased by 27% CER with 14% organic growth and 13% through acquisitions (the five acquisitions above together with Sens-Tech which was acquired in the last two years). The effects on the Group of the conflict in Ukraine are negligible.

Continuing Revenue £m	FY 2021/22	FY 2020/21	%	FY 2021/22	FY 2019/20	%
Reported	379.2	302.8	25%	379.2	303.3	25%
FX translation impact		(6.9)			(5.5)	
Underlying (CER)	379.2	295.9	28%	379.2	297.8	27%
Acquisitions: last 12mths	(31.3)					
Acquisitions: last 24mths				(40.9)		
<b>Organic</b>	<b>347.9</b>	<b>295.9</b>	<b>18%</b>	<b>338.3</b>	<b>297.8</b>	<b>14%</b>

### Orders and Order Book

Continuing Group orders increased by 48% CER to £453.0m, and by 36% organically compared with the Covid-impacted prior year and importantly, by 48% CER and 32% organically compared with the pre-Covid year two years ago.

The book to bill ratio for the year was 1.19:1 (H1: 1.26:1; H2: 1.12:1) building on the momentum of the second half last year (book to bill: 1.16:1) as the Group recovered from the sharp impact of Covid in the first half last year (book to bill: 0.90:1). Two years ago the comparable book to bill ratio was 1.03:1.

While this year's second half ratio was lower than the first half, this was due to the stronger comparators with organic orders still being 1% higher than in the first half.

During the year, the Group order book for continuing operations also grew very strongly and finished the year at a record level of £224m, being 86% (CER) higher than a year ago. Organically the order book increased by 62% in the year and by 71% compared with the pre-Covid period two years ago. Sequentially, the order book increased by 13% (CER) during the second half.

## Group Operating Profit and Margin

Continuing Group underlying operating profit for the year was £41.4m, a 34% increase on last year (FY 2020/21: £30.8m), delivering an underlying operating margin of 10.9%, 0.7ppts higher than last year (FY 2020/21: 10.2%).

Underlying operating profit growth has been achieved through a combination of organic growth, efficient operational execution and acquisitions. Operationally, incremental profits on organic sales growth of £7.3m have been delivered across the two divisions, being a drop-through ratio of 14%. During the year there has been progressive investment in operating expenditure across both divisions to support organic growth this year and in the future, with an average investment of 5.5% p.a. over the last two years. Gross margins have been robust despite supply chain headwinds, although semiconductor shortages, which have delayed sales in two of our 20 businesses, have impacted their manufacturing recovery rates with Group organic margin reducing 0.7ppts overall.

£m	Underlying Operating Profit
FY 2020/21	30.8
Gross profit on organic sales growth	19.4
Organic gross margin	(2.3)
Investment in opex	(9.8)
Organic profit growth – operations	7.3
Profit from acquired companies	6.5
Investment in central capabilities	(0.8)
Additional LTIP charge	(1.9)
Foreign exchange impact	(0.5)
<b>FY 2021/22</b>	<b>41.4</b>

Acquired companies contributed £6.5m of underlying operating profit since acquisition being CPI, Antenova and Beacon acquired this year, together with an annualisation of profits from Phoenix and Litor acquired last year.

Centrally, the Group has invested £0.8m in additional resources to support growth plans, including ESG, risk & internal audit and IT to support operating company system upgrades. Further investment is anticipated in the next 12 months in particular in M&A and IT.

The EPS growth impact on share based payment accruals, the accrued cost of national insurance contributions ("NIC") on LTIPs and the increased rate of NIC since April 2022 have added an additional cost of £1.9m relative to last year.

Reported Group continuing operating profit for the year (after accounting for the underlying adjustments discussed below) was £20.9m, £3.8m (+22%) higher than last year.

Continuing operations £m	FY2021/22			FY2020/21		
	Operating Profit	Finance Cost	Profit before tax	Operating profit	Finance cost	Profit before tax
Underlying	41.4	(3.8)	37.6	30.8	(3.6)	27.2
<b>Underlying adjustments</b>						
Acquisition expenses	(6.5)	–	(6.5)	(1.2)	–	(1.2)
Amortisation of acquired intangibles	(14.0)	–	(14.0)	(11.1)	–	(11.1)
IAS 19 pension cost	–	–	–	(1.4)	–	(1.4)
<b>Reported</b>	<b>20.9</b>	<b>(3.8)</b>	<b>17.1</b>	<b>17.1</b>	<b>(3.6)</b>	<b>13.5</b>

## Underlying Adjustments

Underlying adjustments for the year comprise acquisition & integration expenses of £6.5m (FY 2020/21: £1.2m), and the amortisation of acquired intangibles of £14.0m (FY 2020/21: £11.1m). From this year, the IAS 19 pension administration cost has been taken as a continuing cost of the business. Last year's pension cost comprised the administration cost of £0.4m and a one off adjustment of £1.0m relating to historic commutation terms for legacy scheme members.

Acquisition expenses of £6.5m are the costs associated with acquisition activity during the year of £3.0m, principally of CPI, Antenova and Beacon, accrued contingent consideration costs of £3.1m and the £0.4m for the integration of Hobart into Noratel. The £2.9m increase in the amortisation charge since last year to £14.0m relates to the amortisation of intangibles relating to the five acquisitions since the first half of last year. The annualised amortisation charge for next year is approximately £16.5m.



## FINANCIAL REVIEW

### Financing Costs

Net finance costs for the year were £3.8m (FY 2020/21: £3.6m) and include a £0.6m charge for leased assets under IFRS 16 (FY 2020/21: £0.6m). Finance costs related to banking facilities of £3.2m (FY 2020/21: £3.0m) were slightly higher than last year reflecting marginally higher average net debt during the year.

### Underlying Tax Rate

The underlying effective tax rate for continuing operations for the year was 25%, 1ppt ahead of last year's rate (FY 2020/21: 24%) reflecting increased profits accruing in higher tax territories.

The overall effective tax rate for continuing operations was 43% (FY 2020/21: 30%). This was higher than the underlying effective tax rate due to there being no tax relief on certain acquisition-related expenses and a lower rate of tax relief on the amortisation of acquired intangibles (both within underlying adjustments above). The effective tax rate ("ETR") on intangibles was further impacted this year by the enactment of the increase in the UK corporate tax rate from 1 April 2023, resulting in a one-off increase in the deferred tax liability (a non-cash item).

£m	FY 2021/22		FY 2020/21	
	PBT	ETR	PBT	ETR
Continuing operations	37.6	25%	27.2	24%
Acquisition expenses	(6.5)	12%	(1.2)	10%
Amortisation of acquired intangibles	(14.0)	9%	(11.1)	19%
IAS 19 pension cost	-	-	(1.4)	19%
<b>Total reported</b>	<b>17.1</b>	<b>43%</b>	<b>13.5</b>	<b>30%</b>

### Group Profit Before Tax and EPS

Continuing Group underlying profit before tax for the year of £37.6m was £10.4m higher (+38%) than last year (FY 2020/21: £27.2m), with underlying EPS for the year increasing by 31% to 29.4p (FY 2020/21: 22.4p). The increase in underlying EPS was lower than that for underlying profit before tax due to the higher effective tax rate (+1ppt) and the issuance of new equity in September 2021 increasing fully diluted shares by 4% to 95.8m shares (FY 2020/21: 92.2m shares). The annualised fully diluted shares for the full year is expected to be c. 98m shares.

After the underlying adjustments above, reported profit before tax on continuing operations was £17.1m, an increase of £3.6m (+27%) compared with last year (FY 2020/21: £13.5m). With the reported effective tax rate for the year of 43% being higher than last year's rate of 30% (as mentioned above), the resulting reported fully diluted earnings per share on continuing operations was 10.1p, 0.2p lower than last year (FY 2020/21: 10.3p).

Continuing operations £m	FY 2021/22		FY 2020/21	
	PBT	EPS	PBT	EPS
<b>Underlying</b>	<b>37.6</b>	<b>29.4p</b>	<b>27.2</b>	<b>22.4p</b>
<u>Underlying adjustments</u>				
Acquisition & integration expenses	(6.5)		(1.2)	
Amortisation of acquired intangibles	(14.0)		(11.1)	
IAS 19 pension cost	-		(1.4)	
<b>Reported</b>	<b>17.1</b>	<b>10.1p</b>	<b>13.5</b>	<b>10.3p</b>



## Discontinued Operations

During the year, the Group completed the disposals of the Acal BFi and Vertec SA distribution businesses which have been treated for accounting purposes as discontinued operations. In accordance with IFRS 5, net profits (profit after tax or "PAT") of discontinued operations, which includes the profit on disposal of the businesses, have been shown separately to the results of the continuing operations.

Total operations £m	FY 2021/22		FY 2020/21	
	PBT	EPS	PBT	EPS
Continuing operations	9.7	10.1p	9.5	10.3p
Discontinued operations	15.5	16.2p	2.5	2.7p
<b>Total operations</b>	<b>25.2</b>	<b>26.3p</b>	<b>12.0</b>	<b>13.0p</b>

## Working Capital

Working capital at 31 March 2022 was £57.2m, equivalent to 13.9% of annualised second half sales at CER and was £4.4m (7%) lower than the prior year-end (31 March 2021: £61.6m). This reduction is due to the disposal of the Custom Supply division in the year which had £15.6m of the Group's working capital last year end.

For continuing operations, working capital increased by £11.2m to support the significant increase in sales (+28% growth CER) and at 13.9% was 0.4ppts better as a percentage of annualised second half sales at CER (FY 2020/21: 14.3%) reflecting continuing tight management across the Group. Debtor days were 47 days, creditor days were 80 days and stock turns were 3.4 turns. Stock turns reduced by 0.3 turns on a continuing basis (£4m) reflecting the increase in inventories given current supply chain pressures. Working capital performance was similar in both divisions.

## Cash Flow for Continuing Operations

Net debt at 31 March 2022 was £30.2m compared with £47.2m at 31 March 2021.

£m	FY 2021/22	FY 2020/21
Opening net debt at 1 April	(47.2)	(61.3)
Free cash flow (see table below)	21.8	28.1
Discontinued operations	38.4	9.5
Acquisition-related costs	(87.6)	(21.8)
Equity issuance (net of taxes)	52.6	0.1
Dividends paid	(9.4)	(2.8)
Foreign exchange impact	1.2	1.0
<b>Net debt at 31 March</b>	<b>(30.2)</b>	<b>(47.2)</b>

Net acquisition-related costs of £87.6m in the year comprised £58.8m for the acquisition of Beacon in September 2021, £18.2m for Antenova in August 2021 and £8.1m for CPI in May 2021 (all on debt free, cash free bases). Additionally there were £2.5m of expenses associated with acquisitions during the year. Together with the acquisitions of Phoenix and Limator during the six month period ended 31 March 2021, a total of £109.4m has been spent on acquisitions during the last 18 months.

Group acquisitions were partly funded from a 6% placing of shares in September 2021 which raised net equity proceeds of £53.4m; £0.8m of national insurance contributions paid in respect of executive share options which were exercised during the year. Net cash of £38.4m was raised from discontinued operations with a further £5m of deferred consideration due to the Group in three years' time. Dividends of £9.4m were paid during the year, compared to only £2.8m last year when no final FY 2019/20 dividend was declared as management sought to preserve cash at the outset of Covid.



## Strategic Report

# FINANCIAL REVIEW

Operating cash flow and free cash flow for continuing operations (see definitions in note 2 to the Group financial statements) for the year compared with last year are shown below.

£m	FY 2021/22	FY 2020/21
Underlying profit before tax	37.6	27.2
Net finance costs	3.8	3.6
Non-cash items	12.5	10.4
<b>Total EBITDA</b>	<b>53.9</b>	<b>41.2</b>
IFRS 16	(5.1)	(4.2)
<b>EBITDA (pre IFRS16)</b>	<b>48.8</b>	<b>37.0</b>
Working capital	(10.2)	5.6
Capital expenditure	(5.5)	(3.1)
<b>Operating cash flow</b>	<b>33.1</b>	<b>39.5</b>
Finance costs	(3.2)	(3.1)
Taxation	(6.2)	(6.5)
Legacy pensions	(1.9)	(1.8)
<b>Free cash flow</b>	<b>21.8</b>	<b>32.0</b>
Operating cash (ex working capital)	43.3	28.1
Free cash flow (ex working capital)	32.0	22.5

EBITDA of £53.9m was 31% higher than the Covid-impacted last year (FY 2020/21: £41.2m) and the pre-Covid period two years ago (FY 2019/20: £41.2m) reflecting strong organic sales growth combined with contributions from the five acquisitions made in the last 18 months.

During the year, the Group invested £10.2m in working capital to support organic sales growth contrasting with last year's £5.6m inflow resulting from the reduction in sales following the onset of Covid. In combination, over the last two years only £0.7m has been invested in working capital despite organic sales growth of 14% across that period, reflecting further significant improvements in working capital efficiency.

Capital expenditure of £5.5m was invested during the year including capacity expansions in Mexico and on ESG initiatives including solar panels in Sri Lanka, the Group's largest facility. This saw a return to more normal levels following a reduction during the Covid-impacted last year to maintenance levels only

(FY 2020/21: £3.1m). Capital expenditure levels are expected to increase next year to around £8.5m for the full year as we continue to invest in additional capacity, system upgrades and the roll out of our ESG initiatives.

£33.1m of operating cash was generated in the year. While this was below last year's £39.5m, this was due to working capital inflows last year of £5.6m resulting from the reduction in sales due to Covid. Excluding working capital, operating cash was up 28% on last year. £33.1m of operating cash flow represents 80% of underlying operating profit (FY 2020/21: 128%). While this was below our 85% target due to the strong organic sales growth, the two year conversion rate of 101% is well ahead. Over the last ten years, the Group has consistently achieved high levels of cash conversion, averaging in excess of 100%.

Finance cash costs of £3.2m were marginally ahead of last year while corporate income tax payments of £6.2m were £0.3m lower than last year reflecting refunds of R&D tax credits.

Free cash flow (being cash flow before dividends, acquisitions, disposals and equity issuance) for the year was £21.8m. While this was 22% lower than the prior year, it was 42% higher excluding working capital. Our free cash flow conversion rate this year was 77% of underlying net profit (FY 2020/21: 136%). While this was below our 85% target due to the strong organic sales growth, the two year conversion rate of 102% is well ahead illustrating the strength of the Group's cash generation.

### Banking Facilities

During May 2022, the Group increased its syndicated banking facility from £180m to £240m and extended the remaining term of the facility by two years out to four years ending in June 2026, with an option exercisable by the Group to extend the facility by a further year to June 2027. In addition, the Group has an £80m accordion facility which it can use to extend the total facility up to £320m. The syndicated facility is available both for acquisitions and for working capital purposes, and now comprises seven lending banks.

With net debt at 31 March 2022 of £30.2m, the Group's gearing ratio at the end of the year (being net debt divided by underlying EBITDA as annualised for acquisitions) was 0.6x, the lowest Group gearing ratio since 2015. With our target gearing range being between 1.5x and 2.0x, there is plenty of funding capacity for future acquisitions.



## Balance Sheet

Net assets of £290.4m at 31 March 2022 were £82.0m higher than at the end of the last financial year (31 March 2021: £208.4m). The increase primarily relates to the net issuance of equity of £53.5m (nearly all being the equity placing in September 2021) and net profit after tax for the year of £25.2m (which includes the profit on disposal of discontinued operations). This has been partly offset by dividend payments this year of £9.4m. The movement in net assets is summarised below:

£m	FY 2021/22
Net assets at 31 March 2021	208.4
Net profit after tax	25.2
Dividend paid	(9.4)
Net equity issuance	53.5
Currency net assets – translation impact	7.6
Gain on defined benefit scheme	1.7
Share based payments (inc tax)	3.4
<b>Net assets at 31 March 2022</b>	<b>290.4</b>

## Defined Benefit Pension Scheme

The Group's IAS19 pension position associated with its legacy defined benefit pension scheme improved during the year by £3.7m, from a £1.0m deficit at 31 March 2021 to a £2.7m surplus at 31 March 2022. This partly results from contributions of £1.9m made by the Group; and also from increased corporate bond yields increasing discount rates over the year. These are partly offset by increases in future inflation expectations and updated demographic assumptions during the year.

## Risks and Uncertainties

The principal risks faced by the Group are covered in more detail on pages 54 to 59. These risks comprise: the economic environment, particularly linked to the geo-political issues arising from the ongoing Ukraine conflict and also from Covid; the performance of acquired companies; climate-related risks; loss of

major customers or suppliers; technological changes; major business disruption; cyber security; loss of key personnel; inventory obsolescence; product liability; liquidity and debt covenants; exposure to adverse foreign currency movements; and non-compliance with legal and regulatory requirements.

The Board reviewed the Group's existing and emerging risks and the mitigating actions and processes in place during the financial year, giving specific consideration to the impact of the Ukraine conflict, supply chain headwinds and Covid. The Board view that risks associated with the macroeconomic environment and supply chain for existing and acquired businesses has increased during the financial year with no material change to the relative importance or quantum of the Group's other principal risks.

The risk assessment and review are an ongoing process, and the Board will continue to monitor risks and the mitigating actions in place. The Group's risk management processes cover identification, impact assessment, likely occurrence and mitigation actions where practicable. Some level of risk, however, will always be present. The Group is well positioned to manage such risks and uncertainties, if they arise, given its strong balance sheet, committed banking facility of £240m and the adaptability we have as an organisation.

## Simon Gibbins

Group Finance Director

14 June 2022



Strategic Report

# RISK MANAGEMENT

The Board of Directors has overall responsibility for the Group's risk appetite and risk management strategy. Roles and responsibilities for managing risks across the discoverIE Group have been clearly defined as shown in the diagram below.

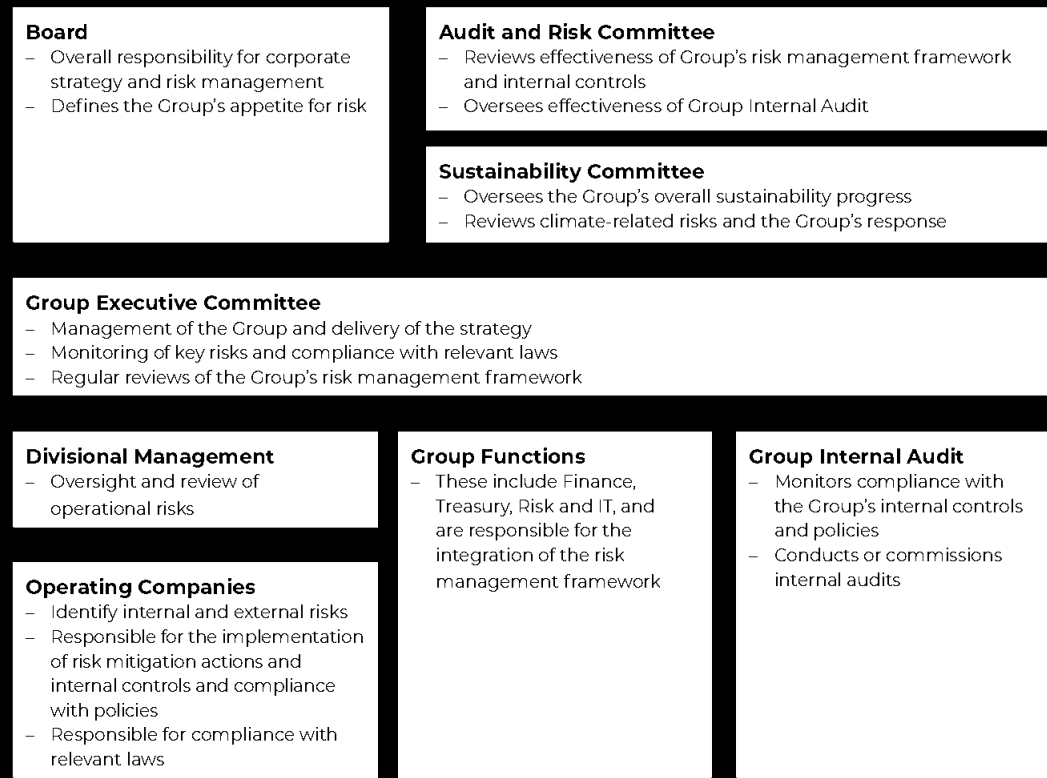

The Company's risk management framework follows a three lines of defence model. The first line of defence is operational management in our businesses. Day-to-day risk management controls, policies and procedures are implemented and monitored by the local management teams with oversight and review by Divisional Management. This is conducted within a series of delegated authority levels. Relevant internal control systems are in place to identify, evaluate and manage the Group's business risks.

The second line of defence comprises Group functions such as risk, finance, IT, treasury and tax. This focuses on monitoring and compliance with risk and control systems, and processes implemented by the Group.

The Group Internal Audit function provides independent assurance of the operation of risk management processes, internal controls and governance, and serves as the third line of defence. As well as carrying out full audits on individual entities, the team conducts thematic audits, focusing on specific areas across

the Group. The team conducted the majority of its audit activities remotely during FY 2021/22 due to the ongoing Covid travel restrictions but is expecting this to change as restrictions ease globally. Other activities carried out by the function include reviewing and updating Group policies and improving processes and procedures where opportunities for improvement have been identified during previous audits. During FY 2021/22, the Group Risk and Internal Audit function began preparations for complying with the proposals outlined in the UK's



Department for Business, Energy and Industrial Strategy ("BEIS") reform of UK corporate governance and audit oversight.

The Group operates a decentralised management model that is target and results driven, with a strong culture of open, constructive communication and a willingness to listen. The Group Internal Audit function applies this culture in how it operates and reviews control environments across the Group.

In pursuing the Group strategy, a number of key objectives are agreed annually for the Group and for each business unit. Progress against these is reported on a regular basis to Divisional and Head Office functional management, the Group Executive Committee and the Board. Having a clear understanding of our strategy and objectives assists with the effective identification and management of existing or emerging risks that have the potential to prevent or hinder these objectives from being achieved.

### Risk Profile

The Group's overall risk profile is mitigated by a number of overriding factors, including:

- Our business units operate largely independently of one another and so if an issue arose in any one business, it would be unlikely to affect other businesses in the Group.
- We operate in 20 countries and no single country represents more than 22% of Group turnover or profit.
- Most of the Group's businesses operate on separate IT systems, which assists in minimising the risks of a major cyber security incident affecting the wider Group. During FY 2021/22, a Group-wide project was completed to further enhance cyber security controls across the Group's businesses by implementing consistent web and end-point security as well as introducing a Security Operations Centre ("SOC") to monitor and respond to IT security threats 24/7.
- The Group operates from over 50 separate sites so that, if an incident were to occur at one site, it would not directly affect the other businesses within the Group. Further, there exists the ability to switch production between certain sites if needed. An independent review conducted during FY 2021/22 found that the level of risk posed by climate change to each of the Group's sites was low.
- The Group has very limited reliance on any single customer or supplier, with the largest customer representing approximately 8% of revenue.

- The Group manufactures and sells multiple product lines, across multiple geographies and market sectors, removing reliance on any single revenue stream. This is further reinforced by the innovative, bespoke nature of the Group's products, which continue to evolve as circumstances change.
- The Group operates in structural growth markets, which reflect long-term needs and are less cyclical in nature.

The Group's performance and adaptability throughout the Covid pandemic demonstrates the resilience of the Group's model.

### Risk Appetite

One of the Group's core principles is to deliver its strategic priorities in a sustainable and responsible manner. This requires that the Board gives careful consideration to the nature and level of risks that the Group should accept.

The Group draws a clear distinction between those risks that it is more willing to take (typically relating to advancing business prospects) and those that it is less willing to accept (e.g. safety, reputational, regulatory or compliance risks). The following table provides a summary:

Risk Tolerant (Willing to take greater risk)	Risk Neutral (Taking a balanced approach to risk)	Risk Averse (Taking as little risk as possible)
Product innovation	Investment in facilities	Product safety
Operating in new markets	Business development initiatives	Health & safety
	Acquisitions	Cyber risks
	New customers and suppliers in existing markets	Regulatory/covenant compliance
	Foreign exchange translational risk	Foreign exchange transactional risk
		Markets with greater business cyclicity
		Environmental risks

Regardless of the appetite in respect of a particular risk, all risks are identified and managed in the appropriate manner.

## RISK MANAGEMENT

### Enterprise Risk Management

discover!E applies the Enterprise Risk Management framework to identify potential events or circumstances that may affect the Group and to manage the associated existing and emerging risks. The risk management framework is made up of a number of discrete steps to identify, assess, mitigate and monitor risks.

#### Step 1

#### Two processes are conducted in parallel:

- A top-down review of the Group Risk Register to:
  - identify new or emerging risks
  - assess changes to existing risks
  - consider the potential impact and likelihood of risks, linking each risk to the Group's corporate strategy
  - evaluate existing mitigating actions and controls
  - consider the residual risks remaining after the applications of the Group's internal control processes (and if appropriate the implementation of further mitigating actions)
- A bottom-up review by the management of each business to:
  - identify new or emerging risks
  - assess changes to existing risks
  - consider the potential impact of risks
  - evaluate existing mitigating actions and controls
  - consider residual risks (and if appropriate the implementation of further mitigating actions)

The top-down review of the Group Risk Register is conducted by the Group Risk team, Divisional Management and the internal Group Sustainability Team. The bottom-up review is conducted by the management team within each business with support from the Risk team.

#### Step 2

- Comparison of the results of the top-down and bottom-up identification processes above
- The benefits of conducting both top-down and bottom-up reviews are:
- increased assurance that all risks have been identified, with input from multiple perspectives
  - ensuring alignment between local management and Head Office
  - ensuring that businesses take ownership of the risks most relevant to their individual operating unit
  - ensuring that controls in place to mitigate risks at the operating unit level are appropriate
- An assessment of any differences identified and update of the Group Risk Register as appropriate

#### Step 3

- Review of the Group Risk Register by the Group Executive Committee. This review focuses on:
  - the materiality of each of the risks identified
  - prioritisation of the allocation of the Group's resources to the most important areas
  - clarity of ownership for each of the risks identified

This review takes into account the Group's risk appetite in respect of the various types of risk identified.

The Group Risk Register is then updated as appropriate following the review.

This is then summarised in a table of principal risks and uncertainties, the final version of which (for FY 2021/22) is set out on pages 54 to 59.

#### Step 4

- Review by the Audit and Risk Committee – this includes:
  - consideration of the Group's risk management framework
  - review of the Group Risk Register
  - identification of any other areas of potential risk
  - review of the table of principal risks and uncertainties
  - challenging actual or potential control weaknesses
  - review of the effectiveness of the Group's internal controls and risk management systems

These processes are conducted twice each financial year:

- an interim review, typically completed shortly ahead of announcement of the Group's interim results, focuses predominantly on changes during the period.
- a comprehensive review of all risks within the Group Risk Register is completed shortly prior to the Group's full-year preliminary results announcement.

The Group Risk function is continually looking to improve the Group's Enterprise Risk Management framework and is currently looking to increase the frequency with which reviews of the Group Risk Register take place to further improve the Group's agility in responding to emerging risks. Further information on the Group's principal risks and uncertainties ("PRUs") is detailed on pages 54 to 59.

A key element in assessing the Group's principal risks is considering likelihood and potential magnitude of impact, over a range of time horizons, as well as whether the risks are new or emerging, or have changed in importance during the year. The below diagram provides a summary of the PRUs on that basis.

### Risk heat map

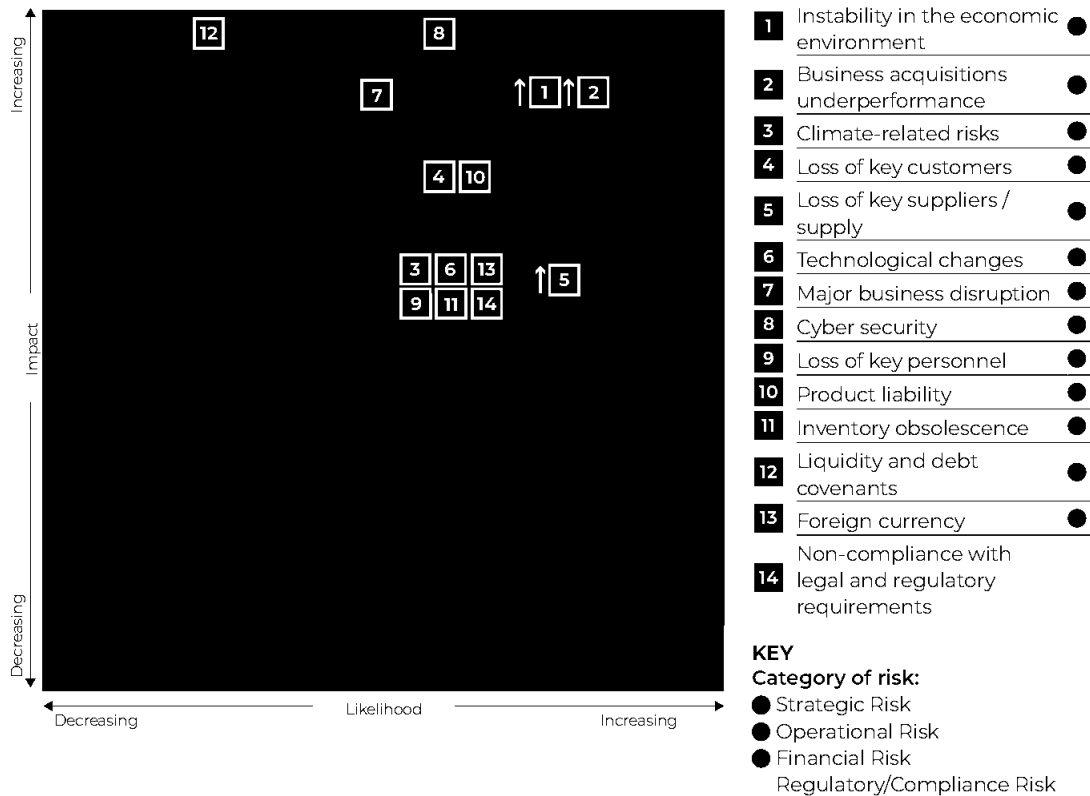

# RISK MANAGEMENT

### Ongoing monitoring, mitigation and improvement

In addition to the processes outlined above, key risks, and the internal control processes adopted to address these risks, are monitored on an ongoing basis. Among other controls, this includes a review by the Group Executive Committee in all of its regularly scheduled meetings (typically seven per year) and escalation to the Board of any material developments as and when they arise.

discoverIE continually pursues improvements in its Enterprise Risk Management Framework. A summary of this continual cycle of risk identification, establishment of systems and processes to mitigate, communication and ongoing monitoring, is outlined in the below diagram.

### Climate-related risks and opportunities

To ensure that the Group continues to thrive under a changing climate, we have undertaken an initial analysis of the resilience of our business model and strategy in two climate scenarios – world surface temperatures to rise by less than 2°C and by more than 4°C compared with pre-industrial levels – representing the best and worst case scenarios.

The assumptions used in our analysis are from the Intergovernmental Panel on Climate Change ("IPCC") Representative Concentration Pathway ("RCP"), the International Energy Agency ("IEA") and other publicly available information.

We assess a number of parameters, such as policy changes and market trends, under each scenario over the short, medium and long term. The analysis shows that the risks the Group faces during the transition to a low carbon economy are low and more than outweighed by the opportunities in the short to medium terms; and that the physical risks over the long term in the worst case scenario can be mitigated.

Further analysis will be carried out in the next 12 months to quantify the potential financial impact, which will be reported in the next year's Annual Report.

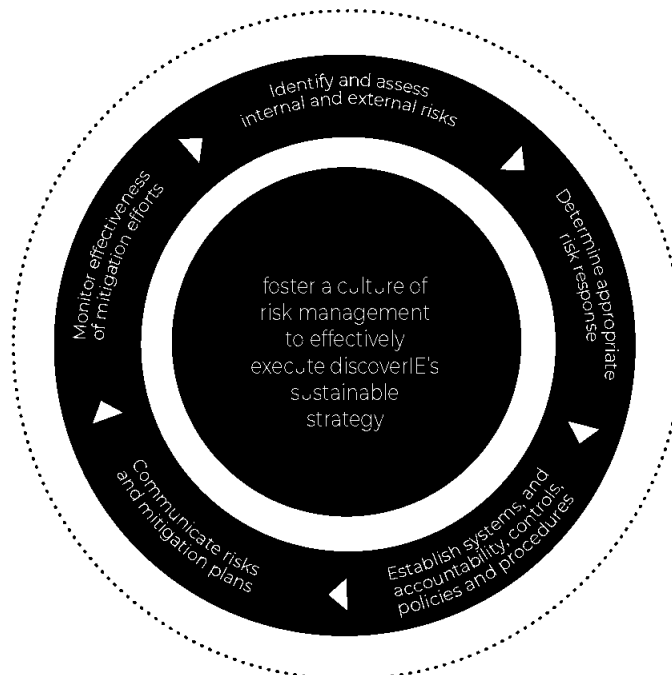



	Below 2°C (RCP 2.6 Scenario)	Exceed 4°C (RCP 8.5 Scenario)
Surface temperature <sup>1</sup>	The “best case” scenario that is in line with the Paris Agreement’s stated 2°C limit /1.5°C aim.	The “worst case” scenario that projects world surface temperatures to rise by more than 4°C compared with the pre-industrial period.
Emissions <sup>2</sup>	Aggressive mitigation and ambitious carbon reductions. Carbon emissions to peak around 2020 then decline on a linear path and become net negative before 2100.	No mitigation, “Business as Usual” and emissions continue rising at the current rate until 2100.
Carbon price	Prices in OECD markets reach \$224/tonne by 2030 and \$120/tonne by 2050 based on a scenario of limited supply of carbon credits <sup>3</sup> .	Prices remain at \$30/tonne. <sup>4</sup>
Energy mix <sup>5</sup>	Increasing proportion of energy from renewable sources, primarily solar and wind.	Fossil fuels remain the main energy source.

1 IPCC AR5 Synthesis Report, p11  
 2 IPCC AR5 Synthesis Report, p9  
 3 Bloomberg Long-Term Carbon Offset Outlook 2022  
 4 OECD Effective Carbon Rates 2021  
 5 IEA Net Zero by 2050 – a roadmap for the global energy sector, p63

**Global average surface temperature change (relative in 1986-2005)**

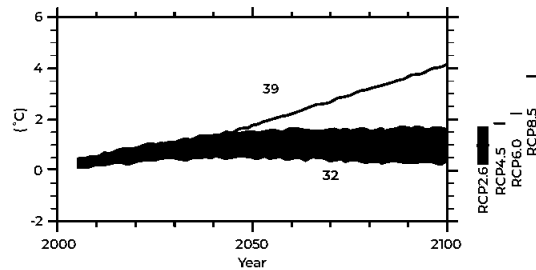

**Annual anthropogenic CO<sub>2</sub> emissions**

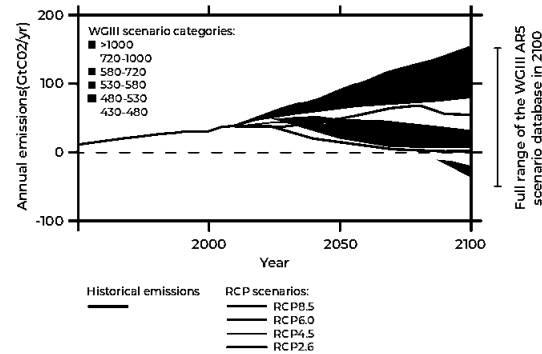

Source: IPCC AR5 Synthesis Report



Strategic Report

## RISK MANAGEMENT

	Description	Potential impact	Our response	
<b>Transition risks</b>				
<b>Short term</b>	<b>Policy &amp; regulation</b>	Aggressive policies to mitigate carbon emissions drive increases in carbon pricing	Low	Over 80% of the Group's Scope 1 and 2 carbon emissions are from the electricity it consumes. We are switching our operations to renewable tariffs where available and have also started investing in onsite generation, such as the installation of solar panels in Sri Lanka and heat pumps in Norway and Poland. We also have plans in place to reduce our energy consumption and other carbon emission factors, such as cars and gas heating, which will reduce our reliance on carbon offset. This risk is therefore considered to be immaterial.
	<b>Technology</b>	New and emerging technologies substitute existing products and services and/or disrupt the existing business model	Low	The Group's products and services are all based on technologies that are ubiquitous (e.g., electromagnetic) and essential for the functioning of electrical and electronic systems. The Group's core competencies are design and customisation, and manufacturing know-how. Our manufacturing processes are often manual or semi-manual value-added assemblies suited for the low volume high mix production mode required for custom-made products. Such a production model is less susceptible to technology changes and does not require substantial capital investment. Further, where technologies do change, our approach of designing-in our products to our end customers' products means that we are well positioned to benefit from such changes, both as a result of being part of the technical innovation and, once designed-in, long life spans of use. Therefore, the risk of technology disruption is considered negligible.
	<b>Market</b>	Increased cost of raw materials	Medium	Our products primarily consist of basic materials such as copper, aluminium and plastics. An increased cost of such raw materials will increase our production costs. Our products are designed and customised for specific applications and are priced according to project specifications. The Group hedges the costs of raw materials two to three months ahead, which helps to reduce any negative financial impact.  The Group's supply chain is resilient, which has been proven through the course of the pandemic. There is ongoing continuous mitigation to identify sustainable multiple sources where possible.

- Short term – 2-3 years
- Medium term – 4-7 years
- Long term – up to 2050



	Description	Potential impact	Our response	
<b>Transition risks</b>				
<b>Short to medium term</b>	<b>Market</b>	Unexpected and abrupt increase in energy costs	Low	Energy is a relatively small part of the Group's operational costs. The impact from any rise in energy costs is unlikely to be material.
		Shifts in customer behaviour	Low	The nature of our products (magnetics, components, boards and sensors) are highly adaptable to a variety of end products, and the exposure of the Group to consumer electronics is negligible.  Our business model is designing and manufacturing customised electronics for specific applications. Our engineers work closely with our customers on solutions that are designed to solve their technical issues. This approach allows us to gain insights of emerging trends. We have positioned ourselves in structural growth markets and expect to benefit from shifts in behaviour over the long-term.
<b>Medium term</b>	<b>Reputation</b>	Increased stakeholder concern on climate change	Low	The electronic components and equipment industry is considered a relatively low carbon emitter and the Group's exposure to carbon-heavy industries such as oil and gas is immaterial.  Since 2020 we have had plans in place to actively reduce carbon emissions in our operations and aim to achieve a 50% reduction in intensity on 2019 emission levels by 2025. In 2021, we reduced our carbon emissions intensity by 33% on a like-for-like basis compared to 2019 levels. The Group expects to invest c £3m by 2025 on carbon reduction initiatives. Hence, the climate-related reputational risk to the Group is relatively low.

- Short term – 2-3 years
- Medium term – 4-7 years
- Long term – up to 2050

## RISK MANAGEMENT

	Description	Potential impact	Our response	
<b>Physical risks</b>				
Long term	<b>Acute</b>	Production disruptions and higher costs from impacts on the workforce as a result of increased severity of extreme weather events such as cyclones and floods	Low	The Group's manufacturing facilities are in 30 locations across Asia, Europe and North America. If necessary, some production activities can be transferred to other locations to ensure business continuity. The Group has experience of transferring manufacturing between sites where circumstances have required us to do so.
	<b>Chronic</b>	Increased operational, capital and insurance costs due to changes in extreme variability in weather patterns, rising temperatures, and sea levels	Medium	The Group has a number of manufacturing facilities in coastal areas. The IPCC RCP 8.5 scenario (the worst case) projects global temperatures to rise by 3.2-5.4°C by 2100 vs pre-industrial levels and sea levels rise to peak at 0.8 metres. Based on this scenario, our initial assessment conducted through the coastal risks screening tool indicated that the physical risks to our manufacturing facilities are considered low. Only one of the Group's 30 manufacturing facilities could be affected and the Group would mitigate this by relocating the facility if necessary.
<b>Opportunities</b>				
Short to medium term	<b>Markets</b>		High	The Group's strategy focuses on markets with sustainable growth, such as renewable energy, electrification of transportation, industrial automation and connectivity. Over 50% of the Group's sales were from these markets in FY 2021/22. Demand in these markets is expected to accelerate during the transition to a low carbon economy. With the knowledge and know-how, and strong position that we have in these markets, the Group is well placed to capitalise on these trends.
	<b>Energy source</b>		Medium	Switching to renewable energy supplies and active reductions of carbon emissions means that the Group: <ul style="list-style-type: none"> <li>is less exposed to future fossil fuel price increases</li> <li>is less sensitive to changes in cost of carbon</li> <li>increases capital availability as more investors prefer low-emissions producers</li> </ul>

● Short term – 2-3 years  
● Medium term – 4-7 years  
● Long term – up to 2050

Please see pages 67 to 69 for our other Task Force on Climate-related Financial Disclosures ("TCFD").





## Strategic Report

# VIABILITY STATEMENT

In accordance with section 4.31 of the 2018 UK Corporate Governance Code, the Directors have assessed the viability of the Group over a 3-year period to 31 March 2025. In making this assessment, the Directors have considered the Group's current financial position, recent and historic financial performance and forecasts, its strategy and business model and the principal risks and uncertainties.

### Viability assessment period

The Directors have concluded that the most appropriate time period over which to assess the Group's prospects for this purpose should be the three-year period ending 31 March 2025. The selection of this period is consistent with the Group's strategic planning process; its review of external credit facilities; and its assessment of the Group's principal risks and uncertainties.

### Viability Base Case

The financial projections for this three-year period are based upon the Group's budget for the year ending 31 March 2023 and forecast progression thereon. The budget is a consolidation of sales, profits, working capital and cash flow forecasts made by each operating company and head office, incorporating associated key risk factors including acquired company forecasts and associated contingent consideration payments, latest views on supplier and customer payments impacting working capital and applicable forecast foreign exchange rates.

The budget for the financial year ending 31 March 2023 assumes a steady organic growth supported by a very strong backlog of orders at the year end. Future growth for the financial years 2023/24 and 2024/25 assume steady sales growth for those years (in total "The Viability Base Case").

### Banking facilities and headroom

The Group has a syndicated banking facility of £240m which is committed up to the end of June 2026, beyond the viability assessment period with an option exercisable by the Group to extend the facility by a further year to June 2027. In addition, the Group has an £80m accordion facility which it can use to extend the total facility up to £320m. The syndicated facility is available both for acquisitions and for working capital purposes.

The Group's financial covenants for its banking facility are:

1. Gearing: net debt to Adjusted EBITDA (being Underlying EBITDA plus the annualisation of acquisitions), excluding IFRS16, of less than 3.0x and
2. Interest cover: Adjusted EBITDA to interest (excluding IFRS16) greater than 4.0x.

At 31 March 2022, the Group had net debt of £30.2m and was significantly inside these covenants with gearing of 0.6x and interest cover of 20x.

The Viability Base Case model shows increasing headroom with annually reducing levels of net debt and gearing, and increasing interest cover compared with the position at 31 March 2022.

### Downside sensitivities

The Viability Base Case has been subjected to downside sensitivity analysis involving flexing a number of the underlying main assumptions, both individually and in conjunction. The sensitivities take into account the principal risks and uncertainties set out on pages 54 to 59, notably instability in the economic environment, underperformance of acquired businesses, climate related risks, loss of key customers and suppliers, major business disruption, liquidity restriction, liquidity and debt covenants and adverse foreign currency movements.

The most severe but plausible downside scenario assumes a worsening of the economic environment caused by a prolonged Ukraine conflict, significant reduction in consumer demand due to inflationary pressures and resurgence of Covid-19. This downside scenario results in a significant decline in second half sales of FY 2022/23, negative sales growth in FY 2023/24 and modest growth thereon in FY 2024/25. Additionally, gross margin was reduced, working capital materially increased, significant one-off expenditures included (product liability, major customer insolvency or litigation, climate change), interest rates increased significantly and an increase in the Group effective tax rate.



After factoring in the significant additional downsides to the Viability Base Case, there remains good headroom both in terms of liquidity and our banking covenants. This is supported by the fact that the Group sells a wide portfolio of different products across a diverse set of industries and geographies, has low customer/supplier concentration, a global supply chain network, diverse manufacturing capacity, and has well-established relationships with its customers. These factors are considered important in mitigating many of the risks that could affect the long-term viability of the Group.

Reverse testing has also been applied to the most plausible downside scenario to determine the level of downside that would be required before the Group would be at risk of breaching its existing financial covenants or current liquidity headroom during the assessment period. The reverse stress test was conducted on the basis that certain mitigating actions would be undertaken to reduce overheads and capital expenditure during the period as sales declined and, on that basis, a fall in underlying operating margin to below 2% would be required before such a breach occurred. The Board considers the possibility of such a scenario to be remote and further mitigation, such as hiring freezes, pay and bonus reductions, headcount reductions, reduction in planned capital expenditure, suspension of dividend payments and equity raise, would be available if future trading conditions indicated that such an outcome were possible.

The Strategic Report on pages 02 to 81 sets out the key details of the Group's financial performance, capital management, business environment and principal risks and uncertainties. Based on the Directors' assessment, the Board has a reasonable expectation that, taking into account the Group's current position, having regard to the committed borrowing facilities available to the Company, and subject to the principal risks and uncertainties faced by the business as documented on pages 54 to 59 of the Strategic Report, the Group will be able to continue in operation and to meet its liabilities as they fall due for the three-year period of their assessment.

### Going Concern

Based on the assessment outlined above, the Directors also believe that it is appropriate to continue to adopt the going concern basis in preparing the Group financial statements.



Strategic Report

# PRINCIPAL RISKS AND UNCERTAINTIES

## Focus on principal risks

This section of the Strategic Report provides an overview of the Group's approach to managing risk, focusing on the major risk factors to implementing the Group's strategy and business model. It is not an exhaustive list of all possible risks. Additional uncertainties exist, some of which may not be known to the Group and could have a negative effect on the Group's financial position and performance. The principal risks and uncertainties detailed below were considered in assessing the long-term viability of the Group. The viability statement can be found on pages 52 and 53.

The categories of risk are similar to last year, save that retirement benefit obligations has been de-classified as a principal risk following the Group's legacy defined benefit pension scheme moving into surplus.

Risk description	Potential impact	Mitigating actions	Change in the year
<b>Strategic risk</b>			
<b>1. Instability in the economic environment</b>			
<ul style="list-style-type: none"> <li>Risk of decline in financial performance due to recession, pandemics or geopolitical changes</li> </ul>	<ul style="list-style-type: none"> <li>Reduction in sales</li> <li>Lower margins</li> <li>Closure of factories and suppliers stopping production</li> <li>Difficulty raising equity and debt, impacting growth ability</li> </ul>	<ul style="list-style-type: none"> <li>Market position as a specialist supplier focused on core target markets with diversified locations and product offerings</li> <li>Executive team actively managing ongoing impact of COVID-19</li> <li>A long-term credit facility is in place with significant headroom</li> <li>Careful monitoring of stock levels and customers in relevant geographies to identify any issues early</li> <li>Flexible production and warehouse facilities to enable movement of production and supply to other countries if required</li> <li>Vigilance entering markets that are politically or financially unstable</li> </ul>	<p><b>Increase</b></p> <ul style="list-style-type: none"> <li>Increased global pressure on prices and supply chain, causing shortages of some raw materials and components</li> <li>Rising interest rates and inflation increase the cost of borrowing</li> <li>COVID-19 impact on global markets generally reduced during the year, as economies start to rebound, partly offset by lockdowns in China</li> <li>Economic crisis in Sri Lanka</li> </ul> <p><b>Link to KSI's:</b> A B C <b>Link to KPI's:</b> 1 2 3 4 5 6 7</p>
<b>2. Business acquisitions underperformance</b>			
<ul style="list-style-type: none"> <li>A degree of uncertainty exists in valuing acquisitions and evaluating potential synergies</li> <li>Post-acquisition risks arise due to change of control and integration challenges</li> </ul>	<ul style="list-style-type: none"> <li>Financial impact due to underperformance of acquisitions</li> <li>Loss of key employees and their expertise</li> <li>Expected synergies are not realised</li> </ul>	<ul style="list-style-type: none"> <li>Operational, financial and legal due diligence on target businesses</li> <li>Appropriate warranties and indemnities from vendors</li> <li>Use of earn-out structures to incentivise key management</li> <li>Monitoring of the acquired business performance against budget and forecast</li> <li>Hiring of experienced finance and management personnel</li> <li>Specific risk management programme for first 12 months post-acquisition before becoming part of the Group ongoing internal audit programme</li> </ul>	<p><b>Increase</b></p> <ul style="list-style-type: none"> <li>A more volatile external economic environment increases the risk of making acquisitions</li> <li>CPI, acquired in May 2021 and Antenova acquired in August 2021, have performed well since acquisition</li> <li>Beacon, acquired in September 2021, has been impacted by a global shortage of semiconductors</li> </ul> <p><b>Link to KSI's:</b> A B C <b>Link to KPI's:</b> 1 2 3 4 5 6</p>



Risk description	Potential impact	Mitigating actions	Change in the year
<b>3. Climate-related risks</b>			
<ul style="list-style-type: none"> <li>Global warming leads to greater extremes of weather events and other local issues</li> <li>Our products or other activities or decisions in relation to climate related risks may be judged negatively by external stakeholders</li> </ul>	<ul style="list-style-type: none"> <li>The operations of Group facilities are affected by the impact of climate change (e.g., through weather related events)</li> <li>Supply chains are affected due to the impact of climate change on their operations</li> <li>Customer revenues are impacted by climate related effects on their businesses</li> <li>Reputational impact and deterioration of relationships with external stakeholders and staff</li> </ul>	<ul style="list-style-type: none"> <li>An initial assessment of the physical risks of climate change to the Group's facilities has been conducted using the Munich Re database; the preliminary analysis indicates that such risks are considered to be low. Please see pages 46 to 50 for our TCFD scenario analysis and our TCFD Report on pages 67 to 69.</li> <li>The Group has diverse supply chains and the ability to switch from individual suppliers that encounter issues</li> <li>Given the Group's target markets, customer revenues are expected to increase as a result of climate-related matters which could offset the risk impact in other areas</li> <li>ESC matters are discussed at all meetings of the Board, Sustainability Committee and Group Executive Committee, to ensure that the right activities are being prioritised and implemented</li> </ul>	<p><b>No change</b></p> <ul style="list-style-type: none"> <li>An analysis of the resilience of our business model and strategy to temperature rises of below 2°C and more than 4°C was completed in the year</li> </ul> <p><b>Link to KSIs:</b> D <b>Link to KPIs:</b> 1 2 3 4 5 6 7</p>
<b>Operational risk</b>			
<b>4. Loss of key customers</b>			
<ul style="list-style-type: none"> <li>A key customer moves to a competitor, significantly reduces operations or goes into insolvency</li> </ul>	<ul style="list-style-type: none"> <li>Loss of market share</li> <li>Increased risk of bad debt</li> <li>Reduced profitability and cash flow</li> </ul>	<ul style="list-style-type: none"> <li>Low dependence on any single customer (the largest customer represents c. 8% of Group revenues)</li> <li>Culture of high-quality service and long-term customer relationships</li> <li>Robust quality management systems (including ISO9001)</li> </ul>	<p><b>No change</b></p> <p><b>Link to KSIs:</b> A B <b>Link to KPIs:</b> 1 2 5 6</p>
<b>5. Loss of key suppliers/supply</b>			
<ul style="list-style-type: none"> <li>A key supplier undergoes change of ownership, suffers major business disruption or quality issues</li> </ul>	<ul style="list-style-type: none"> <li>Negative impact on production</li> <li>Damaged relationships with key customers</li> <li>Reduced sales</li> </ul>	<ul style="list-style-type: none"> <li>Low dependency on any single supplier</li> <li>Dual source suppliers in place where possible</li> <li>Long-term supplier relationships, enhanced by strong customer relationships</li> <li>Monitoring of market and technological developments, including input from customers</li> </ul>	<p><b>Increase</b></p> <ul style="list-style-type: none"> <li>Changes in the external environment have caused shortages in the supply of some materials and components</li> </ul> <p><b>Link to KSIs:</b> A <b>Link to KPIs:</b> 1 2</p>



Strategic Report

## PRINCIPAL RISKS AND UNCERTAINTIES

Risk description	Potential impact	Mitigating actions	Change in the year
<b>6. Technological changes</b>			
<ul style="list-style-type: none"> <li>The development of new technologies that gives rise to significant new competition or renders our products obsolete</li> </ul>	<ul style="list-style-type: none"> <li>Reduced sales</li> <li>Loss of market share</li> <li>Inventory write offs</li> </ul>	<ul style="list-style-type: none"> <li>The Group is diversified into a number of differentiated technology units</li> <li>Focus on established technologies with low capital requirements</li> </ul>	<p><b>No change</b></p> <ul style="list-style-type: none"> <li>Acquisitions in the year increase the diversity of the product portfolio</li> </ul> <p><b>Link to KSIs:</b> A C <b>Link to KPIs:</b> 1 2</p>
<b>7. Major business disruption</b>			
<ul style="list-style-type: none"> <li>Sustained disruption to production arising from a major incident at one or more sites</li> </ul>	<ul style="list-style-type: none"> <li>Insufficient production to deliver goods on order</li> <li>Damaged relationships with key customers</li> <li>Reduced sales</li> <li>Reputational damage</li> </ul>	<ul style="list-style-type: none"> <li>Insufficient production to deliver goods on order</li> <li>Damaged relationships with key customers</li> <li>Reduced sales</li> </ul>	<p><b>No change</b></p> <ul style="list-style-type: none"> <li>Acquisition of CPI and Beacon, with facilities in the US</li> <li>Acquisition of Antenova, with facilities in Taiwan</li> </ul> <p><b>Link to KSIs:</b> A B <b>Link to KPIs:</b> 1 2 3 4 5 6 7</p>
<b>8. Cyber security</b>			
<ul style="list-style-type: none"> <li>System downtime or loss of data due to inadequate systems or external attack</li> </ul>	<ul style="list-style-type: none"> <li>Business disruption</li> <li>Reduced service to customers</li> <li>Financial loss</li> <li>Theft of and/or access to confidential data</li> <li>Reputational damage</li> </ul>	<ul style="list-style-type: none"> <li>Central IT security policy</li> <li>Robust anti-virus and anti-spam software and specialised target threat protection services</li> <li>Robust backup procedures in place</li> <li>Secure private networking</li> <li>Recommendations from third-party cyber security assessments completed in the prior year have been implemented</li> <li>Different operating units operating on separate IT systems minimises risk of a major incident impacting the wider Group</li> </ul>	<p><b>No change</b></p> <ul style="list-style-type: none"> <li>External environment has led to increased number of cyber-attacks on businesses globally</li> <li>Group wide investment in enhanced end-point security solutions, with central monitoring capability, now rolled out.</li> <li>Increased investment and headcount within Group IT team, including new Group Head of IT</li> </ul> <p><b>Link to KSIs:</b> A <b>Link to KPIs:</b> 1 2 5 6</p>



Risk description	Potential impact	Mitigating actions	Change in the year
<b>9. Loss of key personnel</b>			
<ul style="list-style-type: none"> <li>Key employees leave, and effective replacements cannot be recruited on a timely basis</li> </ul>	<ul style="list-style-type: none"> <li>Loss of expertise</li> <li>Potential business disruption</li> <li>Reduced growth</li> <li>Insufficient resources</li> <li>Reputational damage</li> </ul>	<ul style="list-style-type: none"> <li>Staff development, training programmes and succession planning</li> <li>Remuneration based on personal and business success</li> <li>Regular remuneration benchmarking</li> <li>Use of earn-out structures to incentivise key management of acquired companies</li> <li>The number of separate business units, each with their own management teams, minimises the risk that the underperformance of any one business impacts the Group as a whole</li> </ul>	<p><b>No change</b></p> <p><b>Link to KSIs:</b> A <b>Link to KPIs:</b> 1 2</p>
<b>10. Product liability</b>			
<ul style="list-style-type: none"> <li>A failure in one of our products results in serious injury, death, damage to property or non-compliance with product regulations</li> </ul>	<ul style="list-style-type: none"> <li>Non-compliance with quality standards</li> <li>Financial loss</li> <li>Reputational damage</li> </ul>	<ul style="list-style-type: none"> <li>Quality inspection controls before products are shipped to customers</li> <li>Terms and conditions limit companies' liabilities</li> <li>As a number of the Group's products are customised for individual customers, this reduces the risk relating to any one product and/or customer</li> </ul>	<p><b>No change</b></p> <p><b>Link to KPIs:</b> 1 2 3 5 6</p>
<b>11. Inventory obsolescence</b>			
<ul style="list-style-type: none"> <li>Stock is held that has reduced or nil realisable value</li> </ul>	<ul style="list-style-type: none"> <li>Financial loss</li> </ul>	<ul style="list-style-type: none"> <li>Orders built to specific customer requirements; many are non-cancellable, and non-returnable</li> <li>Purchasing to reliable sales forecasts</li> <li>Provisioning and write-off policies to cover potential obsolescence</li> </ul>	<p><b>No change</b></p> <p><b>Link to KSIs:</b> A <b>Link to KPIs:</b> 2 4</p>



Strategic Report

## PRINCIPAL RISKS AND UNCERTAINTIES

Risk description	Potential impact	Mitigating actions	Change in the year
<b>Financial risk</b>			
<b>12. Liquidity and debt covenants</b>			
<ul style="list-style-type: none"> <li>There is a breach of funding terms/covenants</li> </ul>	<ul style="list-style-type: none"> <li>Insufficient cash resources to support the Group's activities</li> </ul>	<ul style="list-style-type: none"> <li>The Group has an existing revolving credit facility of £240m which runs to June 2027 with c.£190m undrawn at the year end</li> <li>Central treasury function oversees the Group's cash resources and financing requirements</li> <li>Regular review of headroom against committed facilities and financial covenants</li> <li>Working capital controls and monitoring of key working capital metrics</li> <li>Issuance of equity from time to time to support acquisitions programme</li> <li>Acquiring high margin, high cash generative businesses</li> </ul>	<p><b>No change</b></p> <ul style="list-style-type: none"> <li>Gearing reduced in the year from 1.1x to 0.6x</li> <li>Revolving credit facility increased from £180m to £240m, with term extended from June 2024 to June 2026, with a Group option to extend to June 2027</li> </ul> <p><b>Link to KPIs:</b> 3 4 5 6</p>
<b>13. Foreign currency</b>			
<ul style="list-style-type: none"> <li>With only 10% of sales in Sterling, the Group deals in many currencies for both its purchases and sales, which differ to its reporting currency, and so the Group has translational and operational exposures to foreign currency fluctuations</li> </ul>	<ul style="list-style-type: none"> <li>Reduction of the Group's reported results</li> <li>Lower gross and operating margins</li> </ul>	<ul style="list-style-type: none"> <li>Use of forward currency contracts to hedge committed and forecast sales and purchases in foreign currency</li> <li>Currency borrowings as a natural hedge against same currency assets</li> <li>Central review of foreign currency exposures</li> </ul>	<p><b>No change</b></p> <p><b>Link to KPIs:</b> 2 5 6</p>



Risk description	Potential impact	Mitigating actions	Change in the year
<b>Regulatory/compliance risk</b>			
<b>14. Non-compliance with legal and regulatory requirements</b>			
<ul style="list-style-type: none"> <li>Unintentional failure to comply with international and local legal and regulatory requirements</li> </ul>	<ul style="list-style-type: none"> <li>Fines or penalties</li> <li>Reputational damage</li> </ul>	<ul style="list-style-type: none"> <li>The Group hires employees with relevant skills and uses external advisers to keep up to date with changes in regulations and legal requirements in order to remain in compliance</li> <li>Internal control framework including Group policies, procedures and training in risk areas such as export controls and supplier and customer credit risk. Annual internal controls self-assessments used to identify and address gaps in control within Group businesses</li> <li>Supplier code of conduct issued during the year and annual supplier audits undertaken across the Group</li> <li>Ongoing internal audit reviews assess compliance with Group policies</li> <li>A whistleblowing hotline is in place and available for use by all employees</li> <li>Insurance covers all standard categories of insurable risk</li> </ul>	<p><b>No change</b></p> <ul style="list-style-type: none"> <li>TCFD regulations came into force this financial year</li> </ul> <p><b>Link to KPIs: 5 6</b></p>

#### Key strategic indicators

- A Increase underlying operating margin
- B Build sales beyond Europe
- C Increase target market sales
- D Reduce carbon emissions

#### Key performance indicators

- 1 Sales growth
- 2 Underlying EPS growth
- 3 Dividend growth
- 4 Return on capital employed
- 5 Operating profit conversion
- 6 Free cash conversion

# SUSTAINABILITY REPORT



**“The Group’s strategy and way of operating is focused on meeting our goals without compromising the ability of future generations to meet their own.”**

**Rosalind Kainyah**  
Chair of the Sustainability Committee

**Dear Shareholder,**

I am delighted to have joined the discoverIE Board and to have been asked to chair the newly established Sustainability Committee.

The Committee has now been formed and will have a pivotal role in shaping how the Group evolves going forward. Please see [www.discoverIEplc.com](http://www.discoverIEplc.com) for the Committee’s Terms of Reference.

During my induction, one of the most thorough I’ve experienced, I met with senior management and visited several of the Group’s operating businesses.

The experience confirmed what I had heard about a well-run organisation full of energy and entrepreneurial spirit, and with the concept of sustainability driving and integrated into core business. The Group’s strategy and way of operating is focused on meeting our present needs without compromising the ability of future generations to meet their own.

In this report, I will report on discoverIE’s sustainability achievements to date and plans for the future. This is also the first year that the UK mandatory requirement of TCFD (Task Force for Climate-related Financial Disclosures) reporting comes into force. The Group has conducted an initial assessment of the resilience of its business model and strategy, and potential impacts of climate change under several transition pathway scenarios in the short, medium, and long terms. It has concluded that the Group may be exposed to certain risks during the transition to a low carbon economy, however such risks are outweighed by the opportunities presented to the Group. See the TCFD section starting on page 67 for more details.

discoverIE’s business model of designing and manufacturing customised products has stood the test of time, even during the most challenging period of the pandemic. The Group’s focus on target markets that have long-term structural growth characteristics has proven to be the right strategic choice, evident in the Group’s outperformance in these markets relative to other markets. Additionally, these target markets, namely renewable energy, electrification of transportation, medical, and industrial automation & connectivity, are in the areas where the Group can fulfil its purpose – that is to create innovative electronics that help improve the world and people’s lives. They are also aligned with the UN Sustainable Development Goals (“UN SDGs”). See pages 61 and 62 for the positive impacts from our products and operations.

This Report comprises:

- **Part 1** – The positive impacts we create through our products and operations
- **Part 2** – A summary of our “three pillars” on which our sustainability programme is based (Our Planet, Our Products, Our People)
- **Part 3** – Governance arrangements
- **Part 4** – Our Priorities & TCFD Report
- **Part 5** – Key metrics

The Group had already undertaken a materiality assessment to help identify those topics that are most significant for its operations and is keen to prioritise its efforts accordingly (see pages 60 and 61 of last year’s Annual Report for a summary).

## Part 1 - Our positive impacts

UN SDG	What is this	How our products create positive impacts	How our operations create positive impacts
	<p>Ensure healthy lives and promote well-being for all ages</p>	<p>We design and make products that go into medical devices and systems, such as ultrasound machines and defibrillators, contributing directly to the health and wellbeing of people.</p> <p>The Group's sensing products are used in environmental management systems, such as indoor temperature monitoring and water treatment plants.</p> <p>Applicable markets:</p>	<p>The Group has 30 manufacturing sites. It's our responsibility to ensure that our employees operate in a safe and clean environment. Our health &amp; safety representatives to employees ratio at the end of 2021 was 1:38, well ahead of guidance, and our accidents and near misses records were better than the benchmark. See page 74 for health &amp; safety performance.</p> <p>Several of our operating businesses have implemented flexible and hybrid working at the end of the pandemic to enable employees to achieve a better work-life balance. A number of them have also completed mental health first aider training, which is increasingly important given the wider impact that the pandemic and associated lockdowns have had on mental health.</p>
	<p>Ensure access to affordable, reliable, sustainable and modern energy for all</p>	<p>Renewable energy is the target market for both our electromagnetic and sensing products. We provide transformers, switches, and sensors for wind and solar systems, supporting the expansion and adoption of renewable and clean energy.</p> <p>Applicable markets:</p>	<p>We support the growth of renewable energy generation by switching to clean energy tariffs where possible. Higher demand leads to more investment.</p> <p>Where possible, we invest in renewable energy self-generation, such as building roof top solar panels in our Sri Lankan plant, contributing to overall renewable energy capacity.</p>

### Applicable Markets Key:



Renewable Energy



Transportation



Medical



Industrial and Connectivity

Strategic Report

## SUSTAINABILITY REPORT

UN SDG	What is this	How our products create positive impacts	How our operations create positive impacts
	Build resilient infrastructure, promote inclusive and sustainable industrialisation and foster innovation	<p>We supply connectivity solutions that underpin the “Internet of Things” (“IoT”) that brings people and communities together and enables automation and efficiency.</p> <p>Applicable markets:</p>	<p>We are an electronic engineering company and we design and create innovative electronics that help to improve the world and people’s lives.</p> <p>Our engineers work with our suppliers and customers to create innovative solutions that solve technical challenges.</p>
	Make cities and human settlements inclusive, safe, resilient and sustainable	<p>Our products play a crucial role in the electrification of transportation and energy efficiency. We provide charging solutions for electric vehicles and power solutions for mass transport such as trains and e-buses, helping to reduce the use of fossil fuels.</p> <p>Applicable markets:</p>	<p>We are a global company but a local operator. Our operating businesses and employees have a strong connection to the communities in which they operate. Through our operating businesses, we create jobs and contribute to the social and economic well-being of the communities through tax revenues, local employment, donations and volunteering.</p>
	Take urgent action to combat climate change and its impacts	<p>Our focus on products that reduce or replace carbon emissions, and aiding electrification, automation and improving efficiencies, assists in combating climate change.</p> <p>Applicable markets:</p>	<p>We play our part in tackling climate change by reducing resource consumption, such as energy and water, recycling where possible in our operations.</p> <p>We also design products that are more energy efficient and less harmful to the environment than the ones they replace.</p>

Applicable Markets Key:



Renewable Energy



Transportation



Medical



Industrial and Connectivity



**Part 2 - Our “Three Pillars”**

The diagram below summarises the core pillars of our sustainability strategy (Our Planet, Our Products and Our People), how they come together to meet Our Purpose, and how they are underpinned by our internal governance arrangements.

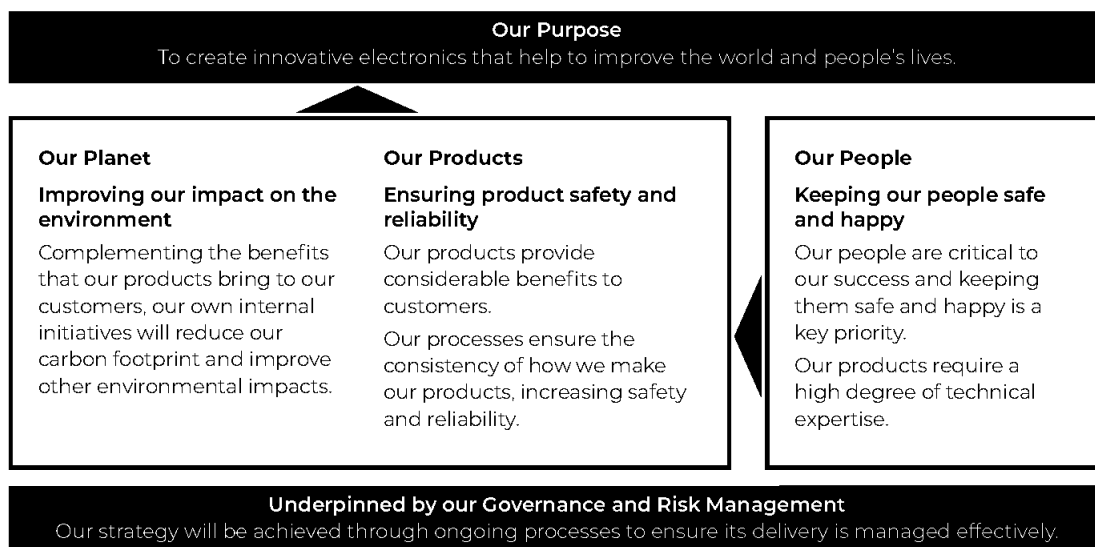

# SUSTAINABILITY REPORT

## Part 3 – Governance

The following diagram summarises the Group’s overall governance arrangements for its sustainability programme.

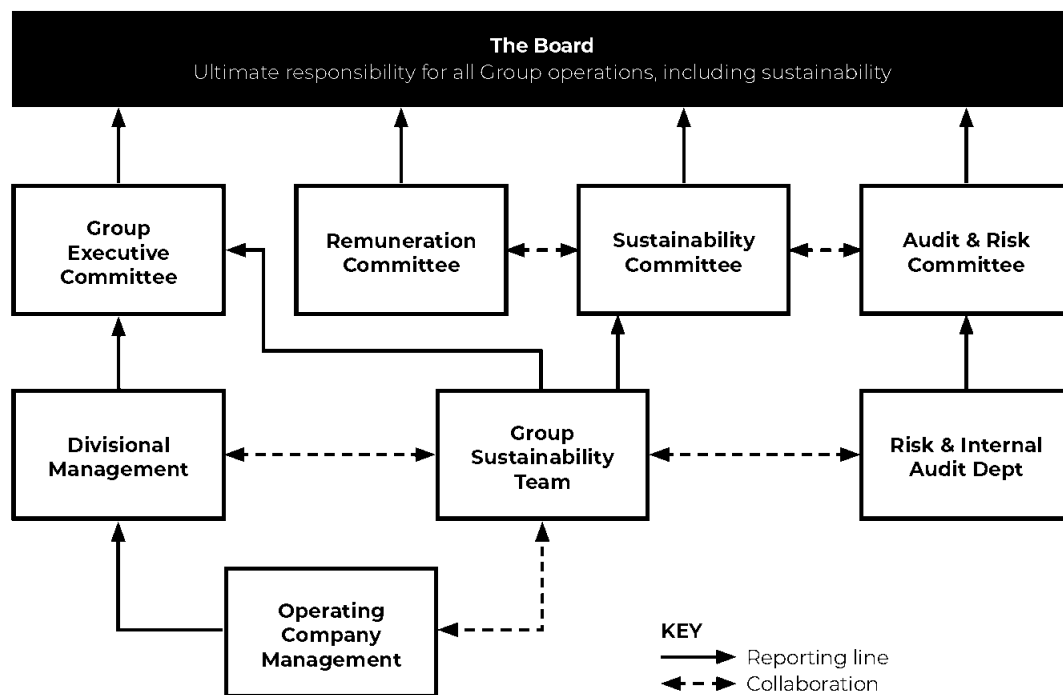

While the Board has ultimate responsibility for sustainability matters (including climate-related risks), it relies on the input and guidance of its various Committees, as well as the Group Executive Committee (“GEC”). The Remuneration Committee ensures that pay is aligned with the Group’s ESG objectives, the Audit & Risk Committee considers governance and risks relating to sustainability matters and climate-related risks in particular, and the Sustainability Committee helps set the Group’s overall ESG strategy and ensures the Board has access to the knowledge and skills required in this area.

The GEC is responsible for overseeing implementation of strategy throughout the Group, with each member of the GEC having ESG-specific targets within their personal objectives and bonus plans. However, it is operating companies that run the Group’s operations and ultimately have to put the Group’s sustainability plans into action. The decision-making process involves all stakeholders working together. The Group Sustainability Team drives initiatives throughout the Group, liaising with operating companies to consider what is practical and feasible, and reporting into the GEC and Sustainability Committee, who provide challenge and direction. This is a constant and evolving process as a result of which strategy, priorities, plans and actions are aligned. During the year, the Group adopted new and updated Policies, held ESG workshops and implemented various initiatives, as noted elsewhere in this Annual Report. All of these actions were as a direct result of the processes outlined above.

While we have made good progress already, further work is required in this evolving area. This will involve all of the above stakeholders working closely together, alongside external advisors to provide further insights, challenge and guidance. The Group has carefully considered its governance arrangements in this context and will keep these under review as we continue to make progress in this key area.

As well as the general governance structures in place as set out above, discover!E has a range of Policies that it expects all of its businesses to adhere to. These include the following (all available at [www.discover!Eplc.com](http://www.discover!Eplc.com)):

Policy	Comment
<ul style="list-style-type: none"> <li>Anti-Bribery &amp; Corruption Policy</li> </ul>	<ul style="list-style-type: none"> <li>During the year ended 31 March 2022, the Group undertook a risk assessment specifically focused on anti-bribery &amp; corruption matters, updated its Policy (which is in the process of being translated into all of the Group's predominant languages) and commenced additional training.</li> </ul>
<ul style="list-style-type: none"> <li>Board Diversity Policy</li> </ul>	<ul style="list-style-type: none"> <li>The Board adopted its first Diversity Policy in May 2021 and updated it in May 2022, with revised targets in line with latest guidance.</li> </ul>
<ul style="list-style-type: none"> <li>Conflict Minerals Policy</li> </ul>	<ul style="list-style-type: none"> <li>This Policy seeks to ensure that none of the Group's operations are exposed to sourcing conflict minerals anywhere in its operations.</li> </ul>
<ul style="list-style-type: none"> <li>Environmental Policy</li> </ul>	<ul style="list-style-type: none"> <li>This Policy summarises the Group's overall environmental objectives and focus.</li> </ul>
<ul style="list-style-type: none"> <li>Human Rights Policy</li> </ul>	<ul style="list-style-type: none"> <li>Respect for the well-being of all people, staff, customers, suppliers and other stakeholders alike is at the core of who we are and how we work. Treating people fairly, with dignity and respect is essential to our long-term success.</li> </ul>
<ul style="list-style-type: none"> <li>Modern Slavery Statement</li> </ul>	<ul style="list-style-type: none"> <li>discover!E is committed to ensuring that no forms of modern slavery exist in its business operations or supply chains.</li> </ul>
<ul style="list-style-type: none"> <li>Supplier Code of Conduct</li> </ul>	<ul style="list-style-type: none"> <li>This Code defines the Group's basic requirements of suppliers and in particular their responsibilities to their stakeholders and the environment.</li> </ul>
<ul style="list-style-type: none"> <li>Group Tax Strategy</li> </ul>	<ul style="list-style-type: none"> <li>We seek to minimise exposure to material tax risk, ensure that tax affairs are managed efficiently, comply with tax laws in all jurisdictions and avoid aggressive tax planning.</li> </ul>
<ul style="list-style-type: none"> <li>Whistleblowing Policy</li> </ul>	<ul style="list-style-type: none"> <li>The Group encourages a "speak up" culture at all levels, if any kind of risk exists or wrongdoing has occurred. A secure and confidential hotline to an independent third party is provided and has been made available and advertised to all staff at all of the Group's locations.</li> </ul>

Pages 42 to 46 set out our general approach to risk management.

In addition to those general processes, and in addition to ongoing supplier checks conducted by our businesses in the normal course of trading, the Group conducted a centralised audit of the Group's largest suppliers during the year. That audit was focused primarily on compliance with our Supplier Code of Conduct and our Modern Slavery Statement. The audit covered suppliers representing 62% of Group procurement spend. No major concerns were identified but potential improvements were identified with a small number of suppliers. This programme of Group-wide supplier audits will continue on an annual basis.



# SUSTAINABILITY REPORT

## Part 4 – Our Priorities & TCFD Report

### Our Planet

#### Greenhouse gas emissions

Addressing carbon emissions is a global challenge that discoverIE stands to benefit from due to its target markets. The technological requirements of the transition to a low carbon economy and the related market response to that challenge present significant opportunities for us as we continue to grow.

We are also committed to playing our part in directly reducing our carbon emissions and so, as announced previously, have set ourselves an initial target to reduce our emissions by 50% from 2019 levels within five years. This will be achieved through a combination of buying electricity from renewable sources, implementing energy reduction measures (including those identified through our programme of energy audits) and installing renewable energy electricity sources on site, as appropriate. A number of sites already use onsite renewable energy sources to reduce emissions, including heat pumps in Poland and Norway, and an onsite solar array in New Jersey.

During the year ended 31 March 2022:

- We continued to reduce our carbon emissions. As at the end of CY2021, our emissions were 33% lower than CY2019 levels, demonstrating the good progress made towards our 50% reduction target
- We completed the first phase of installation of solar panels at our site in Sri Lanka. This is now operational and we will move onto the second and third phases shortly
- Third party energy audits were conducted at a number of sites, identifying further opportunities to increase energy efficiency
- The proportion of our car fleet that is now hybrid or fully electric increased from 19%<sup>1</sup> of vehicles to 26%

<sup>1</sup> The figure reported last year (9%) included Acal BFi; the above figure of 19% excludes Acal BFi from prior year figures.

Our programme of energy audits will continue in the coming year and we will continue to switch company vehicles to electric or hybrid as leases expire and suitable options are available. Once each energy audit is completed, a schedule of recommended actions is agreed. The decision as to whether to implement the recommended actions is made on a return on investment ("ROI") basis, focused on both the reduction in emissions achieved and cost savings that will accrue to the business over the life of the relevant investment. As an example, the upfront investment on the solar panels being installed in Sri Lanka is expected

to be repaid in full four to five years after being commissioned and thereafter reduce ongoing costs.

#### Waste

All Group companies take measures to minimise waste in the manufacture of products, use recycling options where available and reduce packaging.

Although the majority of our products are non-hazardous, where such items are involved, environmental risks are minimised by use of appropriate labelling and technical information, in conjunction with training and procedures for handling, storage and disposal.

The Group has implemented procedures to comply with the Restriction of the Use of Hazardous Substances in Electrical and Electronic Equipment Regulations 2004 ("RoHS"), the Waste Electrical and Electronic Equipment Regulations 2006 ("WEEE"), the Producer Responsibility Obligations (Packaging Waste) Regulations 2005 and the Waste Batteries and Accumulators Regulations 2009.

#### Water

We have undertaken a preliminary assessment of the Group's use of water and determined that the risk of water scarcity is not a material concern. The Group does not use water within its production processes, with the exception of a single, minor process within one business unit. The only water used is for sanitary and drinking purposes.

#### ISO14001 accreditations

ISO 14001 is an internationally agreed standard that sets out the requirements for an environmental management system. It helps organisations improve their environmental performance through more efficient use of resources and reduction of waste, gaining a competitive advantage and the trust of stakeholders. Importantly, it provides an objective and independently assessed view of an organisation's environmental credentials.

Last year, the Group set itself a target to ensure that at least 80% of its operations (measured by revenue) would be covered by an ISO14001 accreditation by 2025. As at the end of CY2021, that figure stood at 63% and the accreditation process has already started at a number of our other businesses, with more scheduled next year and the year after. From feedback received, it is clear that both customers and suppliers value our businesses having this in place.

There were no fines relating to environmental non-compliance during the year or the previous 3 years.



## TCFD Report

The following report is prepared in accordance with the UK Listing Rule 9.8.6(8) and is consistent with the recommended disclosures of the 2017 final report of the Taskforce for Climate-Related Financial Disclosures ("TCFD").

To identify climate-related risks and opportunities ("CRO"), in 2021 the Group conducted an initial assessment of the resilience of its business model and strategy in the best and worst case scenarios of climate change. Details can be found in the Risk Management section on pages 46 to 50. Further analysis will be carried out in the next 12 months to quantify the potential financial impact, which will be reported in the next year's Annual Report.

The Group's current strategy for climate change is set based on the Group's Scope 1 and Scope 2 emissions, where data is available. The Group operates a decentralised model, which increases the scale and complexity of capturing Scope 3 emissions from its supply chain, which are not currently disclosed. The Group plans to identify and quantify these Scope 3 emissions within the next two years and to start reporting in FY2024. The Group's climate change strategy may change accordingly to take into account all Scope 3 emissions if they are deemed material. Scope 3 emissions from the Group's own operations are disclosed on page 73.

Governance	Disclosures
<p><b>Recommended disclosure</b></p> <p>a) Describe the board's oversight of climate-related risks and opportunities.</p>	<p>The Board exercises oversight of climate-related risks and opportunities through:</p> <ul style="list-style-type: none"> <li>the Sustainability Committee, which comprises the whole Board. The Chair of the Committee has 30 years of combined operational, management and board level experience in ESG. The Committee sets the Group's sustainability strategy and monitors the implementation of the strategy</li> <li>the Risk and Audit Committee, which assesses and reviews climate-related risks and opportunities as part of the risk management process</li> <li>the Remuneration Committee, which sets the Group's remuneration policy and ensures that sustainability objectives and performance are linked to management's remuneration.</li> </ul> <p>See the Group's sustainability governance framework on page 64.</p>
<p><b>Recommended disclosure</b></p> <p>b) Describe management's role in assessing and managing climate-related risks and opportunities.</p>	<p>Climate-related risks are reviewed as part of our six-monthly Risk Register review, along with all other risks.</p> <ul style="list-style-type: none"> <li>Group Executive Committee ("GEC") is responsible for the development and implementation of the Group's sustainability strategy, and setting specific objectives and targets for all Group companies. It reports to the Sustainability Committee on all sustainability-related matters, including climate action</li> <li>Group Sustainability Team, formed by members with sustainability, finance, legal and operations experience, is responsible for monitoring, reviewing, consolidating and reporting Group companies' progress on sustainability implementation. It works with the operating business units to deliver sustainability goals and reports to the GEC</li> <li>Operating company management is responsible for the implementation of sustainability strategy within their individual business units.</li> </ul> <p>See the Group's sustainability governance framework on page 64.</p>



Strategic Report

# SUSTAINABILITY REPORT

Strategy	Disclosures
<p><b>Recommended disclosure</b></p> <p>a) Describe the climate-related risks and opportunities the organisation has identified over the short, medium, and long term.</p>	<p>See Risk Management section on pages 46 to 50 for the disclosures a) and b).</p>
<p><b>Recommended disclosure</b></p> <p>b) Describe the impact of climate-related risks and opportunities on the organisation's businesses, strategy, and financial planning.</p>	
<p><b>Recommended disclosure</b></p> <p>c) Describe the resilience of the organisation's strategy, taking into consideration different climate related scenarios, including a 2°C or lower scenario.</p>	<p>The Group's business model is designing and manufacturing customised electronics for industrial applications. Our engineers work closely with our customers on creating innovative solutions to solve their technical challenges, which enables us to gain insights and knowledge of emerging technology and trends.</p> <p>The Group's products (magnetics, sensors, control interface and systems, and connectivity components) are essential components and enable the functioning of any electrical and electronic systems. The Group's strategy of focusing on the markets that play a critical role in decarbonisation, such as renewable energy and industrial automation, ensures that our products and services remain relevant over the long term and that the Group can capitalise on the growth opportunities during the transition to a low carbon economy.</p> <p>The Group's TCFD scenario analysis can be found on pages 46 to 50 and a summary of our climate related risks and opportunities is in the Principal Risks and Opportunities section on page 55.</p>

Risk Management	Disclosures
<p><b>Recommended disclosure</b></p> <p>a) Describe the organisation's process for identifying and assessing climate-related risks.</p>	<p>The Group, with the help of external consultants, conducted a materiality assessment in 2020 as part of its overall risk and sustainability assessment. The process included identifying the areas that were relevant to the Group and its stakeholders (i.e., customers, employees, suppliers and shareholders) and roundtable discussions of GEC and divisional management who represented the views from the operating businesses. A broad range of economic, environmental, social and governance risks were considered and each risk was prioritised according to its importance to the Group and to its stakeholders</p> <p>The materiality assessment and matrix can be found on page 60 of the 2021 Annual Report.</p>
<p><b>Recommended disclosure</b></p> <p>b) Describe the organisation's processes for managing climate-related risks.</p>	<p>Climate-related risks are managed within the Group's risk management processes, which are outlined in the Enterprise Risk Management framework on pages 42 to 46.</p>
<p><b>Recommended disclosure</b></p> <p>c) Describe how processes for identifying, assessing, and managing climate-related risks are integrated into the organisation's overall risk management.</p>	<p>The process of identifying and assessing climate-related risks can be found in Recommended disclosure a) and b) above. Once the risks are identified and assessed, they are managed through the processes defined by the Group's Enterprise Risk Management framework on an ongoing basis.</p>
Metrics and Targets	Disclosures
<p><b>Recommended disclosure</b></p> <p>a) Disclose the metrics used by the organisation to assess climate-related risks and opportunities in line with its strategy and risk management process.</p>	<p>Energy efficiency and climate change, including carbon emissions, are measured and reported on an annual basis in the form of energy consumption, total carbon emissions in Scope 1 and 2, and carbon intensity. See page 73 for details.</p>
<p><b>Recommended disclosure</b></p> <p>b) Disclose Scope 1, Scope 2, and, if appropriate, Scope 3 GHG emissions, and the related risks.</p>	<p>See page 73 for Scope 1, Scope 2 and Scope 3 emissions related to the Group's operations (excluding Scope 3 emissions incurred in the supply chain).</p>
<p><b>Recommended disclosure</b></p> <p>c) Describe the targets used by the organisation to manage climate-related risks and opportunities and performance against targets.</p>	<p>The Group's carbon emission reduction target, set in November 2020, is to reduce the Group's like-for-like emission intensity by 50% by 2025 from the 2019 levels. Like-for-like is defined as continuing operations only, excluding the disposed businesses and acquisitions completed since 1 January 2020. For the calendar year 2021, the Group has reduced its carbon emission intensity by 33% compared with 2019 levels. Further details can be found on page 73. The Group targets to increase sales into the four target markets to 85% by FY 2024/25. Further details can be found on page 24.</p>



Strategic Report

# SUSTAINABILITY REPORT

## Our People

### Keeping our people safe and happy

#### Health, safety and wellbeing

The Group aims to provide clean, healthy and safe working conditions. In addition to compliance with local regulations, discoverIE promotes working practices that protect the health, safety and wellbeing of its employees and other persons who enter its premises. In line with that aim, the Group introduced a new Group Health & Safety Policy in 2020, to reinforce responsibilities and minimum standards. A summary is as follows:

<b>Responsibility &amp; Ownership</b>	The Group operates a decentralised management structure. The management of each of our businesses is best placed to identify and manage the health and safety risks relevant to their business. They must ensure that those risks are properly identified and managed.
<b>Minimum Requirements</b>	<p>The Policy sets out certain minimum expectations, which are for individual management teams to determine how best to achieve within their businesses. The minimum expectations include the following:</p> <ul style="list-style-type: none"> <li>■ Each business to have its own local Health &amp; Safety Policy and communicate to all concerned</li> <li>■ Appropriate resources must be in place</li> <li>■ Responsible individuals to be identified within each business and those individuals to have suitable training</li> <li>■ Appropriate documentation to be maintained</li> <li>■ A “speak up” culture is to be encouraged, with employees positively asked to identify potential risks or hazards and bring them to the attention of those responsible for health and safety</li> <li>■ Appropriate risk assessments to be performed and recommendations actioned</li> <li>■ Training to be provided</li> </ul>
<b>Reporting</b>	Operating companies report each month in respect of health and safety issues, including the number of on-site accidents, near misses and mitigation. Please see the table on page 74 for a summary of the Group’s lost time incidents.

As at 31 December 2021, the Group had over 120 health & safety representatives across our workforce of c. 5,000 employees, a ratio of 1:38, which is well ahead of guidance and a further improvement on our ratio of 1:47 at the end of the prior year. The Group conducted over 5,500 hours of health & safety training in the year to 31 December 2021.

Recognising the importance of a structured and objectively verifiable approach to Health & Safety, the Group has set an ambitious target to ensure that at least 80% of its global workforce is working in operations covered by an ISO45001 health and safety management system. The bulk of this programme is scheduled for CY2023 and CY2024, with preparation currently underway.

A number of our businesses also have employee assistance and mental health support programmes in place for staff.



## Equality and Diversity

Among its duties, the Sustainability Committee is responsible for oversight of the Group's diversity and discrimination policies and progress has been made during the year, with increased diversity within the Board, Senior Management (being the Group Executive Committee and its direct reports), and in the Group's operational management (see page 74 for details).

The Group is committed to ensuring our people are treated with respect, are empowered and appropriately rewarded. Our employment policies are based on equal opportunities for all, and on there being no discrimination on grounds of gender, race/ethnicity, social background, religion, sexual orientation, family responsibilities (pregnancy), disabilities, political opinion, age, sensitive medical condition or trade union membership.

The policies are fair, equitable and consistent with the skills and abilities of employees and the needs of the Group's businesses and aim to ensure that everyone is accorded equal opportunity for recruitment, training and promotion. The Group does not tolerate any sexual, physical or mental harassment.

Our Board Diversity Policy can be found on the Company website: [www.discoverIEplc.com](http://www.discoverIEplc.com). See page 74 for details of our gender diversity as a group.

## Development and training

Our businesses are proactive in anticipating both short and long term employment needs and skills requirements. All employees are encouraged to actively engage in their career development and extensive training opportunities are available across the Group. We provide technical training to staff, as relevant for their role. This is scheduled and tracked.

Some of the Group's operating companies have structured apprenticeship schemes for technical staff. Employees are actively encouraged to undertake further learning, such as National Vocational Qualifications or similar level courses, as well as continual professional development to maintain any relevant professional accreditations.

The vast majority of employees receive annual performance appraisals.

## Recruitment and retention

Clear and fair terms of employment and a competitive remuneration policy are in place. It is Group policy to communicate with employees on major matters to encourage them to take an interest in the affairs of their employing company and the Group. In addition to the Workforce Advisory Panel that has been established in accordance with Provision 5 of the UK Corporate Governance Code, each operating company is encouraged to maintain effective employee engagement arrangements, including keeping employees aware of the financial and economic factors affecting their employing company's performance. Please see pages 75 and 90 for further details of our engagement.

The Group remains supportive of the employment and advancement of disabled persons. Full consideration is given to applications for employment from disabled persons, where the candidate's particular aptitudes and abilities are consistent with meeting adequately the requirements of the job. Opportunities are available to disabled employees for training, career development and promotion. Where existing employees become disabled, it is the Group's policy to provide continuing employment, wherever practicable, in the same or an alternative position and to provide appropriate training and support to achieve this aim.

## Community Engagement

Our businesses operate within their local communities and discoverIE encourages active engagement. Many of our businesses employ local people from the community in which they operate.

Support for local good causes includes charitable donations and, in certain businesses, opportunities for staff to volunteer. Examples of this include the Group's continued support of the Community Foundation for Surrey and, in Minnesota, staff volunteering to pack donation bags for people in Haiti.

As well as supporting these causes directly, initiatives such as these motivate staff and increase their sense of purpose in working for an organisation that is keen to play a positive role in society.



Strategic Report

## SUSTAINABILITY REPORT

# Our Products

The Group produces high-quality, reliable products that bring considerable benefits to customers and the environment alike.

Raw materials are procured from responsible sources, in accordance with the principles in our Supplier Code of Conduct, Modern Slavery statement and Conflict Minerals Policy (all available at [www.discoverIEplc.com](http://www.discoverIEplc.com)). These are verified through both local checks and the Group-wide supplier audit programme summarised on page 65. In the event of non-compliance we would engage with the supplier to seek measures to rectify the non-compliance.

Wherever possible, recycled raw materials are used in production processes (such as for copper and aluminium, as appropriate).

Our products typically have long life spans. At the end of their lives, products are disposed of in accordance with the applicable standards.

The quality and safety of our products is ensured and monitored through the widespread adoption of ISO9001 systems. As at 31 December 2021, 95% of the Group's

products (measured by revenue) were manufactured under an ISO9001 accredited system. The Group receives very few customer complaints and fault / return rates are very low.

For a summary of some of the benefits that our products bring to the world, including how they help the global fight against climate change, and help people personally, please see our Impact Report 2021 (available at [www.discoverIEplc.com](http://www.discoverIEplc.com)).





## Part 5 – Key Metrics

### Carbon Emissions

The Group's carbon intensity, measured on a like-for-like basis<sup>1</sup>, decreased by 33.12% from the CY2019 base year to CY2021.

Location-based	Total Emissions (tonnes)			Like-for-like Emissions (tonnes)		
	2019	2020	2021	2019	2020	2021
Scope 1	2,742.01	1,644.70	2,106.43	1,862.73	1,133.58	1,331.35
Scope 2	7,298.55	6,600.54	7,628.40	7,030.06	6,380.30	7,202.17
Total Scope 1 & 2 <sup>3</sup>	10,040.56	8,245.24	9,734.83	8,892.79	7,513.88	8,533.52
Scope 3 <sup>3</sup>	590.38	604.08	741.97	572.80	588.28	711.38
Total emissions	10,630.94	8,849.32	10,476.80	9,465.59	8,102.16	9,244.90
Intensity – tCO <sub>2</sub> e / £m revenue (Scope 1 & 2)	21.76	18.25	17.67	29.90	25.26	25.85

Market-based	Total Emissions (tonnes)			Like-for-like Emissions (tonnes)		
	2019	2020	2021	2019	2020	2021
Scope 1	2,742.01	1,644.70	2,106.43	1,862.73	1,133.58	1,331.35
Scope 2	7,895.54	6,732.61	6,087.65	7,527.46	6,450.74	5,640.12
<b>Total Scope 1 &amp; 2<sup>3</sup></b>	<b>10,637.55</b>	<b>8,377.31</b>	<b>8,194.08</b>	<b>9,390.19</b>	<b>7,584.32</b>	<b>6,971.47</b>
Scope 3 <sup>3</sup>	588.34	590.17	601.65	570.76	575.38	578.34
Total emissions	<b>11,225.89</b>	<b>8,967.48</b>	<b>8,795.73</b>	<b>9,960.95</b>	<b>8,159.70</b>	<b>7,549.81</b>
UK based emissions %	9.36	4.46	6.84	n/a	n/a	n/a
Intensity – tCO <sub>2</sub> e / £m revenue (Scope 1 & 2)	<b>23.05</b>	<b>18.54</b>	<b>14.87</b>	<b>31.57</b>	<b>25.50</b>	<b>21.12</b>
<b>Scope 1 &amp; 2 intensity reduction vs 2019 (%)</b>	<b>n/a</b>	<b>19.57%</b>	<b>35.48%</b>	<b>n/a</b>	<b>19.23%<sup>2</sup></b>	<b>33.12%</b>

	Total Energy Consumption			Like-for-like Energy Consumption		
	2019	2020	2021	2019	2020	2021
Energy consumption (kWh)	26,423,158	22,687,513	27,012,262	21,609,107	19,465,803	21,791,630
Energy intensity (kWh/£m revenue)	57,252	50,210	49,029	72,653	65,444	66,005
UK based energy consumption	not disclosed	12.70	9.92	n/a	n/a	n/a

Notes:

- The "Total Emissions" columns include all companies owned by the Group as at the end of each calendar year. The "Like-for-like Emissions" columns represent continuing operations only, i.e. excluding Acal BFI and Vertec SA which are treated as discontinued operations. The like-for-like figures also exclude acquisitions completed since 1 January 2020.
- The reported figure of 19.23% reduction in 2020 was reduced to 6% after adjusting for the effects of Covid to provide an underlying measure.
- Scope 1 and Scope 2 emissions are generated directly from the Group's operations (Scope 1) and indirectly through the energy consumed by the Group (Scope 2). Scope 3 emissions are related to the Group's operations only and exclude emissions from the Group's supply chain.
- Emissions data is reported in accordance with the UK Government's 'Environmental Reporting Guidelines: Including Streamlined Energy and Carbon Reporting Guidance', and the GHG Protocol Corporate Reporting Standard, using the 2020 emission conversion factors published by the Department for Environment, Food and Rural Affairs (Defra) and the Department for Business, Energy & Industrial Strategy (BEIS). The assessment follows the dual reporting approach for assessing Scope 2 emissions from electricity usage. The operational control approach has been used.
- All of the data in the above table has been independently assessed by Carbon Footprint Ltd, a leading carbon & energy management company.



## Strategic Report

# SUSTAINABILITY REPORT

### Health & Safety

Lost-time incident frequency rate (LTIFR) information

	FY19	FY20	FY21	FY22
Lost time incidents (LTIs)	10	18	15	19
Average head count	4281	4394	4269	4522
<b>LTIFR</b>	<b>0.13</b>	<b>0.22</b>	<b>0.19</b>	<b>0.23</b>

Notes:

- 1 LTI or lost time incident is defined as a work-related incident resulting in the loss of five or more work days in the reported period.
- 2 LTIFR is the Number of LTI divided by the total work hours in the reported period, multiplying by 100,000 hours (representing the estimated number of working hours in an employee's work lifetime).
- 3 Reported head count includes all full-time and part-time employees and contractors.
- 4 There were no fatalities among the Group's employees or contractors during any of the four years stated above.

### Diversity

	Senior Management <sup>1</sup>			Operational Management <sup>2</sup>			All employees		
	FY22 (No.)	FY22 (%)	FY21 (%)	FY22 (No.)	FY22 (%)	FY21 (%)	FY22 (No.)	FY22 (%)	FY21 (%)
Total	<b>30</b>			<b>66</b>			<b>4,886</b>		
Male	<b>24</b>	<b>80</b>	85	<b>42</b>	<b>64</b>	82	<b>2,604</b>	<b>53</b>	<b>50</b>
Female	<b>6</b>	<b>20</b>	15	<b>24</b>	<b>36</b>	18	<b>2,282</b>	<b>47</b>	<b>50</b>

<sup>1</sup> Senior Management is the Group Executive Committee and Direct Reports.

<sup>2</sup> Operational Management is defined as divisional management at Group level and the most senior managers in the Group's operating businesses.

### Other ESG KPIs

	2021 <sup>1</sup>	2022	2025 Target
Our Planet			
ISO 14001 accreditations <sup>2</sup>	61%	63%	80%
Energy audits <sup>3</sup>	13%	23%	80%
Company cars (EV/hybrid) <sup>4</sup>	19%	26%	50%
Our People			
ISO45001 accreditations <sup>5</sup>	6%	5%	80%
H&S Representatives <sup>6</sup>	1:52	1:38	1:50
Staff Turnover	10%	13%	<15%
Our Products			
ISO9001 accreditations <sup>7</sup>	88%	95%	80%

<sup>1</sup> All of the 2021 figures are restated so as to exclude Acal BFi and Vertec SA (now sold).

<sup>2</sup> Measured as a % of Group revenues generated by operations with a ISO14001 accreditation.

<sup>3</sup> Measured as a % of the number of the Group's sites that have had an energy audit since 2017.

<sup>4</sup> Measured as the % of the Group's company cars that are electric or hybrid.

<sup>5</sup> Measured as the % of the Group's employees that work in operations covered by an ISO45001 occupational health & safety management system. While no new accreditations were completed in the year, a number are underway and expect to be completed during 2023.

<sup>6</sup> Measured as the proportion of health & safety representatives to the overall number of employees.

<sup>7</sup> Measured as a % of Group revenues generated by operations with a ISO9001 accreditation.

### Rosalind Kainyah

Chair of Sustainability Committee

14 June 2022



## STAKEHOLDER ENGAGEMENT

### Stakeholder engagement

The Group considers it important to engage with our various stakeholder groups in a proactive and constructive manner and the below provides a summary of the ways in which we do so.

Why it is important to engage	Stakeholder key interests	Ways we engage
<p><b>Our people</b></p> <p>Employee engagement is critical to our success. We work to create a diverse and inclusive workplace where employees can reach their full potential. Engaging with our employees ensures we can retain and develop the best talent.</p>	<ul style="list-style-type: none"> <li>▪ Health and safety</li> <li>▪ Reward</li> <li>▪ Career opportunities</li> <li>▪ Employee engagement</li> <li>▪ Training and development</li> <li>▪ Wellbeing</li> <li>▪ Reputation</li> </ul>	<ul style="list-style-type: none"> <li>▪ Annual performance evaluations</li> <li>▪ Employee surveys</li> <li>▪ Employee meetings</li> <li>▪ Workforce advisory panel</li> <li>▪ Newsletters</li> <li>▪ Employee events</li> <li>▪ Apprenticeship programme</li> <li>▪ Recognition and reward</li> </ul>
<p><b>Our companies</b></p> <p>We operate in a decentralised model where our companies are empowered to innovate and grow, and decision-making takes place in the frontline and close to customers. Our companies are key stakeholders of the Group and are vital for our growth strategy.</p>	<ul style="list-style-type: none"> <li>▪ Operational and financial performance</li> <li>▪ International expansion</li> <li>▪ Capital investment</li> <li>▪ Collaboration</li> </ul>	<ul style="list-style-type: none"> <li>▪ Quarterly business reviews</li> <li>▪ Regular site visits</li> <li>▪ Company management forums</li> <li>▪ Support in specialist areas, such as tax, legal and commercial</li> <li>▪ Sustainability workshops</li> </ul>
<p><b>Customers</b></p> <p>Understanding the needs of our customers allows us to provide application-specific products which both add value and differentiate our customers from their competitors. We engage with our customers to build trusting relationships from which we can mutually benefit.</p>	<ul style="list-style-type: none"> <li>▪ Safety, quality and reliability</li> <li>▪ Competitiveness</li> <li>▪ Our availability and responsiveness</li> <li>▪ Relationship</li> <li>▪ Compliance</li> <li>▪ Convenience</li> <li>▪ Range of products</li> </ul>	<ul style="list-style-type: none"> <li>▪ Customer visits, telephone calls, engineering visits</li> <li>▪ Participation in industry forums and events</li> <li>▪ Social media and commercial websites</li> <li>▪ Contract negotiation, implementation and management of ongoing relationships</li> <li>▪ Customer audits of our manufacturing facilities</li> <li>▪ Customer-specific events</li> <li>▪ Geographical footprint allows us to meet customers in their locations</li> <li>▪ Satisfaction surveys</li> </ul>



Strategic Report

## STAKEHOLDER ENGAGEMENT

Why it is important to engage	Stakeholder key interests	Ways we engage
<p><b>Suppliers</b></p> <p>Our external supply chain and our suppliers are critical to our performance. We engage with our suppliers to build trusting relationships from which we can mutually benefit and to ensure that they are performing to our standards and conducting business to our expectations.</p>	<ul style="list-style-type: none"> <li>▪ Quality management</li> <li>▪ Cost-efficiency</li> <li>▪ Long-term relationships</li> <li>▪ Responsible procurement, trust and ethics</li> <li>▪ Technological advances, including digital solutions</li> </ul>	<ul style="list-style-type: none"> <li>▪ Joint customer visits</li> <li>▪ Supplier audits</li> <li>▪ Employee training</li> <li>▪ Quarterly business reviews</li> <li>▪ Geographical footprint allows smaller suppliers to operate globally</li> <li>▪ Logistics efficiencies</li> <li>▪ Supplier conferences</li> </ul>
<p><b>Shareholders</b></p> <p>To understand their requirements and generate returns and value. We ensure that we provide fair, balanced and understandable information to shareholders and investment analysts and work to ensure that they have a strong understanding of our strategy, performance, culture and ambition.</p>	<ul style="list-style-type: none"> <li>▪ Growth</li> <li>▪ Financial performance and economic impact</li> <li>▪ Governance and transparency</li> <li>▪ Operating and financial information</li> <li>▪ Confidence in the Group's leadership</li> <li>▪ Dividend growth</li> </ul>	<ul style="list-style-type: none"> <li>▪ Regular market updates</li> <li>▪ Investor presentations</li> <li>▪ Individual meetings</li> <li>▪ Investor roadshows</li> <li>▪ Corporate website, including dedicated investor section</li> <li>▪ Shareholder consultations</li> <li>▪ Annual reports</li> <li>▪ Annual General Meetings</li> <li>▪ Capital Markets Days</li> </ul>
<p><b>Global communities</b></p> <p>We support communities and groups local and relevant to our operations and consider the environmental and social impacts of our operations.</p>	<ul style="list-style-type: none"> <li>▪ Local operational impact</li> <li>▪ Health and safety and environmental performance</li> </ul>	<ul style="list-style-type: none"> <li>▪ Charitable donations and volunteering</li> <li>▪ Corporate and operating company websites</li> <li>▪ Local environmental initiatives</li> </ul>

The Group promotes policies and procedures across the Group which consider the interests of the Group's employees, the need to foster reasonable business relationships with suppliers, customers and others, the impact of the Group's operations on its workforce, the community and the environment, and the maintenance of high standards of business conduct. Our policies and procedures include the following:

- Anti-bribery and corruption
- Business ethics
- Health and safety
- Whistleblowing
- Board Diversity Policy
- Supplier Code of Conduct
- Conflict Minerals Policy
- Environmental Policy
- Human Rights Policy
- Group Tax Strategy

Day-to-day responsibility for implementation of these policies (other than the Board Diversity Policy) is delegated to the management of discoverIE's operating companies, under the supervision of the Group Executive Committee. Where appropriate, the Group policies and procedures are supported by the local operating companies' policies, all within a framework established by the Board and Group Executive Committee, intended to ensure that we operate as a Group to the highest standards.

The Group also has due diligence processes in place to support the ongoing assessment and management of risks associated with both existing and newly acquired companies and the development of relationships with new suppliers.

These include site visits by both executive and non-executive management, meetings with customers and suppliers and, where relevant, asking our suppliers to confirm compliance with Group policies.

Management are committed to environmental, social and governance affairs in its actions, and endeavours to show due respect for human rights and works to high standards of integrity and ethical propriety.

As an international organisation, discoverIE takes account of cultural differences between the various territories in which it operates. discoverIE's values are essential to how it operates and to the long-term success and growth of the Group.

discoverIE believes that who we are and how we behave matters not only to our employees but the many other stakeholders who have an interest in our business. None of the Group's staff have been disciplined or dismissed for any matter in relation to anti-bribery, corruption or whistleblowing in the current year or any of the last three fiscal years.

Stakeholder engagement remains vital to building a sustainable business and we interact with many stakeholders at different levels of the Group.

Engagement is carried out by those most relevant to the stakeholder group or issue. The table on pages 75 and 76 identifies some of our stakeholders and how discoverIE engages with them.





Strategic Report

## NON-FINANCIAL INFORMATION STATEMENT

In accordance with sections 414CA and 414CB of the Companies Act 2006, we have set out below where the relevant non-financial information we need to report against can be found in this Annual Report:

Environmental matters	<ul style="list-style-type: none"> <li>■ Please see our Sustainability Report on pages 60 to 74 and pages 66 to 69 in particular (Our Planet, including our TCFD Report).</li> <li>■ Please see climate-related risks and opportunities on pages 46 to 50 (which includes TCFD scenario analysis) and on page 55.</li> <li>■ Please see pages 42 to 46 for our general approach to risk management and page 64 for a summary of our governance framework relating to sustainability matters and climate-related risks in particular. These governance arrangements fit within our broader governance framework, for which please see our Corporate Governance Report on pages 86 to 96.</li> </ul>
Employee matters	<ul style="list-style-type: none"> <li>■ Please see pages 70 and 71 (Our People), 75 (Stakeholder engagement – Our people), 80 (Section 172 statement) and 90 (Employee engagement).</li> </ul>
Social matters	<ul style="list-style-type: none"> <li>■ Please see pages 76 and 77.</li> </ul>
Human Rights	<ul style="list-style-type: none"> <li>■ Please see pages 65, 77 and 121.</li> </ul>
Anti-bribery and corruption matters	<ul style="list-style-type: none"> <li>■ Please see page 65 (Anti-Bribery &amp; Corruption Policy and Whistleblowing Policy).</li> <li>■ Please also see pages 77, 91, 98 and 100.</li> </ul>
Business Model	<ul style="list-style-type: none"> <li>■ Please see pages 14 and 15 for Our Business Model.</li> <li>■ Please see pages 16 and 17 for our target markets, pages 18 to 23 for a summary of our strategy and pages 4 to 7 for a summary of the Group.</li> </ul>
Policies	<ul style="list-style-type: none"> <li>■ The following codes, policies and standards can be found at our Group website (<a href="http://www.discoverieplc.com">www.discoverieplc.com</a>):                             <ul style="list-style-type: none"> <li>– Whistleblowing Policy</li> <li>– Anti-bribery Policy</li> <li>– Modern Slavery Statement</li> <li>– Group Tax Strategy</li> <li>– Board Diversity Policy</li> <li>– Supplier Code of Conduct</li> <li>– Conflict Minerals Policy</li> <li>– Environmental Policy</li> <li>– Human Rights Policy</li> </ul> </li> </ul>
Outcome of Policies	<ul style="list-style-type: none"> <li>■ The above policies contribute to the overall governance framework of the Group, providing common standards that operating companies and suppliers must observe.</li> <li>■ The Group has a proven, flexible and resilient business model, as demonstrated by its strong financial performance over several years. These are underpinned by the Group's governance arrangements in general, including the Policies summarised above.</li> <li>■ The Group has good relations with its various stakeholders, including staff, customers and suppliers. The above Policies help support those relations.</li> </ul>
Principal risks	<ul style="list-style-type: none"> <li>■ Where principal risks have been identified in relation to any of the matters listed above, these can be found on pages 54 to 59.</li> </ul>
Non-Financial KPIs	<ul style="list-style-type: none"> <li>■ Our non-financial key performance indicators are set out on pages 73 and 74.</li> </ul>

## SECTION 172 STATEMENT

The Board of discoverIE Group plc takes seriously its duties to act in accordance with legal requirements and appropriate business and ethical standards. This includes fulfilling the duties described in Section 172 of the Companies Act 2006 (the “Act”).

### Section 172

#### Duty to promote the success of the company

A director of a company must act in the way they consider, in good faith, would be most likely to promote the success of the company for the benefit of its members as a whole, and in doing so have regard (amongst other matters) to:

- The likely consequences of any decision in the long term;

- The interests of the company’s employees;
- The need to foster the company’s business relationships with suppliers, customers and others;
- The impact of the company’s operations on the community and environment;
- The desirability of the company maintaining a reputation for high standards of business conduct; and
- The need to act fairly as between members of the company.

The information below describes how the Directors have had regard to the matters referred to in Section 172 of the Act in performing their duties and constitutes the Board’s Section 172 Statement for the year ended 31 March 2022. This section is incorporated by reference into the Strategic Report.

### Section 172 of the Companies Act 2006 (the “Act”)

#### Long-term decision-making (s.172(a))

The Board delegates day-to-day management and decision-making to its senior management team, but it maintains oversight of the Company’s performance, and reserves to itself specific matters for approval, including the strategic direction of the Group, acquisitions and disposals and entering into material contracts above set thresholds.

The Board monitors performance against strategy and that decision-making is appropriate by receiving regular updates, both in Board and Committee meetings and at other intervals as appropriate.

Processes are in place to ensure that the Board receives all relevant information to enable it to make well-judged decisions for the long-term success of the Company and its various stakeholders.

### The discoverIE Board’s response

#### In FY 2021/22, the Board:

Established a new Sustainability Committee (with effect from 1 April 2022). This new Committee will have dedicated responsibility for considering the Group’s response to ESG matters and to sustainability in general.

Considered a number of acquisition proposals. The Board only approves such a transaction if it is satisfied, after full consideration, that it meets the Section 172(1) requirement that it is most likely to promote the success of the Company for the benefit of its members as a whole, and it considers the value forecasted to be added to the Group by an acquisition, over a defined future period. This judgement is recorded.

The Board also considered the disposals of Acal BFi and Vertec SA, each of which were approved and completed during the year.

Received presentations on specific business areas and, through ongoing discussion with the business leaders, determined strategic priorities for a three-year period, and the development of robust supporting operating plans.

Agreed the Group’s principal risks, considered emerging risks and received regular risk management and internal control reviews throughout the year, including specific consideration of risks arising from the Covid outbreak and Russia/Ukraine conflict.

Set annual budgets and capital allocation and oversaw business performance against targets, enabling the Board to confirm the Company’s outlook for the year ahead, the going concern statement and its longer-term viability.



## SECTION 172 STATEMENT

### Section 172 of the Companies Act 2006 (the "Act")

### The discoverIE Board's response

#### Employee Interests (s. 172(b))

The success of the Group depends upon a highly-skilled and motivated workforce, an entrepreneurial and innovative culture, set within structures that provide fairness for all.

#### In FY 2021/22, the Board:

Received updates on how Covid was affecting staff and the measures being implemented within businesses to minimise the risk of the pandemic spreading across the workforce, including working from home where possible.

Continued to operate a Workforce Advisory Panel, to ensure that the communications between the Board, Group Executive Committee, individual operating companies and Group staff were optimised.

Reviewed Board and Senior Management diversity and succession, remuneration and employment relations and arrangements across the Group.

#### Relations with external parties (s. 172(c))

The Group works with a huge number and variety of customers, suppliers and other third parties. It is of great importance that relations with those parties are appropriate.

#### In FY 2021/22:

Noting the continuing pressure that businesses have been under during the Covid pandemic, the Board ensured that suppliers continued to be paid on time and that the Group continued to serve our customers effectively.

The Board regularly considered the marketplaces within which the Group's customers operate and the challenges they face, and opportunities available. This helped shape the way in which resources were allocated in order to ensure that the Group was well positioned to meet customer needs.

#### Community & Environment (s. 172(d))

Wherever the Group operates, it forms a part of its local community and more broadly, seeks to ensure that it provides a positive contribution to the environment.

#### During the year:

The Board continued its focus on environmental, social and governance matters and, in particular, established a new Sustainability Committee, further details of which can be found in the Sustainability Report on pages 60 to 74.

The Board also continued its support for the Community Foundation for Surrey.

#### Reputation for high standards of business conduct (s.172(e))

The Board is responsible for developing a corporate culture across the Group that promotes integrity and transparency. It has established comprehensive systems of corporate governance which promote corporate responsibility and ethical behaviour.

#### In FY 2021/22:

The Board received regular reports from the Group Risk Manager designed to strengthen governance and compliance, integration of new and recent acquisitions into the Group, and the identification and management of existing and emerging risks.

The Board had updates and training on key areas of law and regulation.

The Board approved the Company's Modern Slavery Act Statement.

**Section 172 of the Companies Act 2006 (the “Act”)**

**The discoverIE Board’s response**

**Acting fairly as between members of the Company (s.172(f))**

The Board aims to understand the views of shareholders and always to act in their best interests.

**In order to do this the Board:**

Maintains close relations with its main shareholders through regular dialogue, both after the publication of full-year and half-year results.

Approved value-enhancing acquisitions, CPI in May 2021, Antenova in August 2021 and Beacon in September 2021.

Receives Investor Relations updates at every Board meeting and direct feedback from investors during specific consultation exercises and on publication of trading results and updates.

**Other key activities**

- The Board met regularly throughout the year and, in the year ended 31 March 2022, held nine meetings. The Board’s agenda considers all relevant matters at scheduled meetings.
- As part of its regular programme of Board activities, the Board also receives reports from the Group Chief Executive, the Group Finance Director and the Group General Counsel & Company Secretary, keeping them informed as to financial and commercial performance and regulatory and legal affairs.

The Strategic Report, as set out on pages 02 to 81, has been approved by the Board.

On behalf of the Board

**Nick Jefferies**  
Group Chief Executive  
14 June 2022

**Simon Gibbins**  
Group Finance Director  
14 June 2022



## Corporate Governance

### THE BOARD



**Malcolm Diamond MBE**  
Non-Executive Chairman



**Appointment to the Board**

Chairman since April 2017, Non-Executive Director since November 2015

**Tenure**  
6 years

**Independent**  
Yes

**Previous experience**  
Malcolm brings considerable commercial and international business experience to the Board, as well as City investor knowledge and expertise. Prior to joining the Board, he was Executive Chairman and Chief Executive of Trifast plc and, among other previous appointments, was Senior Non-Executive Director of Dechra Pharmaceuticals Plc and a Non-Executive Director of Unicorn AIM VCT plc.

**External appointments**  
None.



**Nick Jefferies**  
Group Chief Executive



**Appointment to the Board**

January 2009

**Tenure**  
13 years

**Independent**  
No

**Previous experience**  
Nick joined discoverIE as Group Chief Executive in 2009. He started his career as an electronics engineer for Racal Defence (now part of Thales plc), before joining Toshiba and then Hitachi's European electronic component businesses. Prior to discoverIE, he was General Manager for electronics globally at Electrocomponents plc.

**External appointments**  
None.



**Simon Gibbins**  
Group Finance Director



**Appointment to the Board**

July 2010

**Tenure**  
11 years

**Independent**  
No

**Previous experience**  
Simon brings significant financial expertise and experience gained at an international level. Prior to joining the Group, he was at Shire plc for nine years, latterly as Global Head of Finance and Deputy CFO, and at ICI plc for six years in various senior finance roles, both in the UK and overseas. His earlier career was spent with Coopers & Lybrand where he qualified as a chartered accountant.

**External appointments**  
None.



**Tracey Graham**  
Non-Executive Director



**Appointment to the Board**

November 2015

**Tenure**  
6 years

**Independent**  
Yes

**Previous experience**  
Tracey brings significant operational expertise to the Board. During her executive career, Tracey was Chief Executive of Talaris Limited and Managing Director of De La Rue Cash Systems. Prior to that she was President of Sequoia Voting Systems, Customer Services Director at AXA Insurance and held senior positions at HSBC.

**External appointments**  
Non-Executive Director of Link Scheme Limited, Senior Independent Director of Ibstock plc, and Non-Executive Director of Close Brothers Group plc.

## Committee membership

- A Audit and Risk Committee  
 G Group Executive Committee  
 N Nomination Committee  
R Remuneration Committee  
 S Sustainability Committee  
 ● Chairman of the Committee



**Bruce Thompson**  
Senior Independent Director

A N R S

### Appointment to the Board

Senior Independent Director since March 2019, Non-Executive Director since February 2018

**Tenure**  
4 years

**Independent**  
Yes

**Previous experience**  
Bruce brings a wide range of strategic and leadership expertise to the Board with proven experience of growing international industrial businesses. During his executive career, Bruce was Chief Executive Officer of Diploma plc. Prior to joining Diploma, Bruce was a director with the technology and management consulting firm Arthur D. Little Inc., both in the UK and the USA.

**External appointments**  
Non-Executive Director and Chair of Avon Protection plc.



**Clive Watson**  
Non-Executive Director

A N R S

### Appointment to the Board

September 2019

**Tenure**  
2 years

**Independent**  
Yes

**Previous experience**  
Clive is a Chartered Accountant and brings wide-ranging experience in senior financial roles to the Board. Prior to retirement from executive roles, he spent almost 13 years as Group Finance Director of Spectris plc, having previously held a number of other senior finance positions both in the UK and overseas. He also served as Senior Independent Director and Audit Committee Chairman of Spirax-Sarco Engineering plc.

**External appointments**  
Non-Executive Director of Breedon Group plc, Non-Executive Director of Kier Group plc and Non-Executive Director of Trifast plc.



**Rosalind Kainyah**  
Non-Executive Director

A N R S ●

### Appointment to the Board

January 2022

**Tenure**  
6 months

**Independent**  
Yes

**Previous experience**  
Rosalind has extensive experience in sustainability matters and currently runs Kina Advisory, an ESG consultancy. Previously, she was VP, External Affairs & Corporate Social Responsibility at Tullow Oil and held various roles at De Beers SA, latterly as President of De Beers Inc. in the USA.

**External appointments**  
Non-Executive Director of GEM Diamonds Ltd and Non-Executive Director of CalBank plc.



**Greg Davidson**  
Group General Counsel & Company Secretary

G

### Appointment

November 2019

**Tenure**  
N/A

**Independent**  
No

**Previous experience**  
Greg joined discoverIE in November 2019 and is responsible for legal and company secretarial affairs. He is a qualified lawyer with extensive experience of technology, corporate and commercial matters. His experience includes five years at Wiggin & Co LLP, with clients focused predominantly in the technology sector and, prior to joining discoverIE, 16 years at RM plc, with seven years as General Counsel & Company Secretary.

**External appointments**  
None.

## THE GROUP EXECUTIVE COMMITTEE



**Nick Jefferies**  
Group Chief Executive

➤ For biography see page 82



**Simon Gibbins**  
Group Finance Director

➤ For biography see page 82



**Greg Davidson**  
Group General Counsel & Company Secretary

➤ For biography see page 83



**Jeremy Morcom**  
Group Head of Corporate Development

Jeremy was appointed Group Head of Corporate Development in March 2017. A physicist by background, he has over 25 years' experience in industrial mergers and acquisitions, initially in investment banking and then in industry, leading the corporate development programmes at Spectris plc and Invensys plc.



**Martin Pangels**  
Group Commercial Director - Magnetics & Controls Division

Martin joined discoverIE in July 2010 after working as an advisor to the business. Prior to joining discoverIE, he spent nine years at Electrocomponents plc, where he was Regional General Manager for Europe, and six years with Bain & Company as a strategy consultant.



**Paul Hill**  
Group Commercial Director - Sensing & Connectivity Division

Paul joined the Group Executive Committee in December 2021. Paul joined from Antenova, one of the Group's latest acquisitions, where he was Chief Executive Officer. Having started his career in electronics engineering, Paul has worked in electronic components and smart card systems, and held senior operational and board roles in both hardware and software companies.





Corporate Governance

## CORPORATE GOVERNANCE REPORT



**“The Group’s governance structures aim to meet the societal and environmental challenges of today whilst positioning us for continued growth.”**

Malcolm Diamond MBE  
Chairman

### Chairman’s Governance Overview

discoverIE is a strong business, with a clear purpose and set of values. This is underpinned by a governance structure that enables the Group’s long-term objectives to be met.

The Group’s performance over the last year was underpinned by our governance arrangements.

These structures help ensure we are well positioned for continued growth and to meet the social and environmental challenges facing the world today.

Malcolm Diamond MBE  
14 June 2022





## Compliance with the UK Corporate Governance Code 2018

During the year ended 31 March 2022, the Company complied with the UK Corporate Governance Code 2018 (the "Code"), with the exception of provision 38 (alignment of pensions) which, in accordance with guidance, the Company will comply with from 1 January 2023.

Section	Progress made	Further Information
<b>Board Leadership and Company Purpose</b>	The Board leads from the front in setting the tone for the business and has established a clear purpose, set of values and strategy, taking into account the interests of our various stakeholders. The right resources, structures and processes are in place to ensure that these are then implemented properly throughout the Group.	<a href="#">➔ Read more on pages 88 to 91</a>
<b>Division of Responsibilities</b>	The respective roles and responsibilities of the Executive and Non-Executive Directors are clear and consistently applied, providing for constructive and effective dialogue and clear accountability.	<a href="#">➔ Read more on pages 92 and 93</a>
<b>Composition, Succession and Evaluation</b>	The Board has a healthy balance of skills, knowledge and experience and the appointment process is rigorous and carefully applied. Annual evaluations keep the effectiveness of the Board and its Committees under regular review to ensure this remains the case. During the year ended 31 March 2022, an externally facilitated evaluation of the Board and its Committees was completed.	<a href="#">➔ Read more on pages 94 and 95</a>
<b>Audit, Risk and Internal control</b>	The Board has established clear processes and procedures to ensure that risks are carefully identified, monitored and mitigated against and then reported externally in an open and transparent manner. This helps ensure that the Company's financial statements are fair, balanced and understandable. Effective risk management is critical to achieving our strategy.	<a href="#">➔ Read more on page 96</a>
<b>Remuneration</b>	Remuneration supports the Company's strategy and is appropriate to the nature and size of the business. The Board has clear processes in place and aims to report in a straightforward and easy to understand way, with a view to providing external stakeholders with reassurance that pay, performance and wider interests are aligned.	<a href="#">➔ Read more on page 96</a>



Corporate Governance

## CORPORATE GOVERNANCE REPORT

### Board Leadership and Company Purpose Current composition and changes to the Board in the year

Details of the current members of the Board are set out on pages 82 and 83.

In the prior year, it was identified that the Board would benefit from additional ESG experience. As such, Rosalind Kainyah was appointed to the Board during the year ended 31 March 2022. Bruce Thompson is Senior Independent Director, Tracey Graham is Chair of the Remuneration Committee and Clive Watson is Chair of the Audit and Risk Committee.

All of the Non-Executive Directors have considerable expertise in their respective roles.

### Section 172 Statement

The Board takes seriously all of its duties, including those set out in section 172 of the Companies Act 2006. The statement required by section 172(1) explaining how it has taken those duties into account can be found on pages 79 to 81.

### Stakeholder engagement

We engage proactively with our stakeholder groups.

➔ Read more on pages 75 to 77

### Sustainability

Provision 1 of the Code deals with the Company generating value over the long term in the context of future risks and opportunities. This is addressed in the Sustainability Report and in the Risk Management section.

➔ Read more on pages 60 to 74

➔ Read more on pages 42 to 59





## Good governance

Following the introduction of the new Code in 2018, the Board reviewed the Group's governance frameworks and its purpose, culture and values.

### Our Purpose:

To create innovative electronics that help to improve the world and people's lives.

### Values and Culture

#### Values

- To operate with the highest ethical standards and integrity
- To strive for the highest performance standards, not accepting of mediocrity
- To support the protection of the environment through our products and solutions while minimising our direct environmental impact
- To be a responsible employer, with a safe working environment
- To respect, empower, engage and develop our employees in an entrepreneurial environment
- To add value and be a trusted partner to customers, suppliers and shareholders

#### Culture

- Honest, reliable and trusting
- Decentralised decision-making close to the customer
- Open, constructive communication and willingness to listen
- Non-political, non-bureaucratic
- Performance, target and results driven

### Vision:

To be a leading innovator in electronics internationally.

### Mission:

To design and supply innovative customised electronics that help our customers create ever better technical solutions around the world. We aim to achieve this through a motivated, entrepreneurial and empowered workforce that adheres to the highest ethical and quality standards.

In doing so we expect to create value for shareholders, while being seen as an attractive and responsible employer and a trusted partner for customers and suppliers.

### Strategy:

To grow our business in customised electronics by focusing on markets with sustained growth prospects, driven by an increasing electronic content and where there is an essential need for our products.

### Strategic Priorities:

This strategy comprises the following priorities:

- Grow sales well ahead of GDP over the economic cycle by focusing on structural growth markets
- Move up the value chain into higher margin products
- Acquire businesses with attractive growth markets and strong operating margins
- Further internationalise the business by developing sales in North America and Asia
- Generate strong cash flows and sustainable returns while reducing impact on the environment

Progress against our objectives is measured through our key strategic indicators (KSIs) and key performance indicators (KPIs). Details are set out on pages 24 and 25.



## CORPORATE GOVERNANCE REPORT

### Employee Engagement

A high-quality workforce is vital to the success of the Group. There are a range of employee engagement initiatives in place across the Group and these include the following:

- Works Councils and staff representative meetings
- Employee meetings
- Quarterly performance updates
- Staff surveys
- Social and team-building events
- Health & wellbeing reviews
- Workforce Advisory Panel

Since 2009, as part of its annual calendar the Board visits the Group's operating sites, meeting management and employees directly.

In 2017, the Board visited Flux (Copenhagen), in 2018 the Board visited Myrra and Noratel (both in China) and, in 2019, the Board visited Cursor Controls (Newark, UK). Lockdown restrictions meant that Board visits were not possible during 2020 and 2021 but now that they have eased the Board will be visiting Variohm (in the UK) later this year and will schedule similar visits for future years.

The Board aims to visit as much of the Group as possible, visiting facilities in a variety of locations internationally. The Board gains a deeper understanding of the business, local complexities, working conditions, the level of skills and expertise in each facility, the concerns and aspirations of staff, and any issues that the leadership or staff may wish to discuss with the Board.

The purpose of the Workforce Advisory Panel is to ensure that the "employee voice" is heard, that the Board is aware of any issues or concerns that staff may have and to ensure that their views are taken into account and influence the Board's decision-making, where appropriate. This helps the Board to monitor and assess the culture of the organisation.

A number of operational changes have already been implemented as a result of the interaction. In the coming year, it is intended that this will include increased collaboration between different businesses within the Group.

### Time Allocation, Board and Committee Meetings and Attendance

During the year, attendance by Directors at Board and Committee meetings was as follows:

Director	Committees				Overall Attendance %
	Board	Audit and Risk	Remuneration	Nomination	
Malcolm Diamond	9/9	3/3	5/5	2/2	100%
Simon Gibbins	9/9	–	–	–	100%
Tracey Graham	9/9	3/3	5/5	2/2	100%
Nick Jefferies	9/9	–	–	2/2	100%
Rosalind Kainyah <sup>1</sup>	2/2	1/1	2/2	–	100%
Bruce Thompson	9/9	3/3	5/5	2/2	100%
Clive Watson	9/9	3/3	5/5	2/2	100%

<sup>1</sup> Appointed 1 January 2022

Time is provided at the start and the end of each meeting for the Chairman to meet privately with the Senior Independent Director and Non-Executive Directors. The Board's commitments are taken into account in the preparation and planning of meetings to ensure that all Directors are able to allocate sufficient time to discharge their responsibilities.

Board approval is required prior to any Director accepting any external appointments.



## Board activities

Topic	Key activities and discussions in 2021/22	Key priorities in 2022/23
<b>Strategy</b>	<ul style="list-style-type: none"> <li>■ Oversaw the Group's continuing response to Covid</li> <li>■ Reviewed and approved the acquisitions of CPI, Antenova and Beacon</li> <li>■ Reviewed and approved the disposals of Acal BFI and Vertec SA</li> <li>■ Reviewed key strategic indicators ("KSIs") and key performance indicators ("KPIs")</li> </ul>	<ul style="list-style-type: none"> <li>■ Consider acquisitions as identified and determine the appropriate course of action</li> <li>■ Keep KSIs and KPIs under review</li> <li>■ Keep the Group's dividend policy under review</li> <li>■ Continue to focus on international growth in key markets, including expansion into North America</li> </ul>
<b>Risk and risk management</b>	<ul style="list-style-type: none"> <li>■ Carried out robust assessment of principal and emerging risks (see pages 54 to 59)</li> <li>■ Considered the Group's exposure to climate related and other ESG risks</li> <li>■ Conducted a fresh risk assessment of anti-bribery and corruption risks and updated the Group's Anti-Bribery Policy</li> <li>■ Reviewed internal audit reports and actions taken to address findings identified</li> </ul>	<ul style="list-style-type: none"> <li>■ Review key risks and ensure that the Group's internal control process remains appropriate</li> </ul>
<b>Governance</b>	<ul style="list-style-type: none"> <li>■ Established a new Sustainability Committee (formally taking effect from 1 April 2022)</li> <li>■ Continued focus on the composition, balance and effectiveness of the Board</li> <li>■ Considered and approved a range of supplier-focused Group Policies</li> <li>■ Signed off and published the Group's modern slavery statement</li> <li>■ Evaluated supply chain risks, especially in the context of global supply chain challenges and the conflict in Ukraine</li> <li>■ Engaged with institutional shareholders, investors and other stakeholders throughout the year</li> <li>■ Reviewed and approved the FY 2020/21 Annual Report</li> </ul>	<ul style="list-style-type: none"> <li>■ Build further understanding and plan actions in relation to new regulations over the period</li> </ul>
<b>Organisational capacity</b>	<ul style="list-style-type: none"> <li>■ Monitored health and safety performance across the Group. Regular Board updates received on actions improving health and safety</li> <li>■ Received presentations by senior management including on M&amp;A strategy</li> </ul>	<ul style="list-style-type: none"> <li>■ Continue to monitor health and safety performance across the Group</li> <li>■ Consideration of the Group's capacity as it continues to grow</li> </ul>
<b>Board development</b>	<ul style="list-style-type: none"> <li>■ Continued focus on the composition, balance and effectiveness of the Board</li> <li>■ Reviewed Board and Committee composition and discussed and acted on the recommendations of the Nomination Committee</li> <li>■ Undertook an externally facilitated evaluation of the Board, its Committees and individual Directors</li> </ul>	<ul style="list-style-type: none"> <li>■ Focus on increasing diversity both for the Board and across the Group more generally</li> </ul>

## CORPORATE GOVERNANCE REPORT

### Division of Responsibilities

discover!E is led by a strong and experienced Board with a broad range of skills, experience and knowledge.

Throughout the year under review, the Board consisted of Malcolm Diamond as Non-Executive Chairman, Tracey Graham, Rosalind Kainyah (appointed 1 January 2022), Bruce Thompson and Clive Watson as Non-Executive Directors, with Nick Jefferies as Group Chief Executive and Simon Gibbins as Group Finance Director.

The composition of the Board is kept under review by the Nomination Committee on an annual basis. Following the Group's entry to the FTSE250 during the year, it was decided that an additional Non-Executive Director should be added to the Board, with the relevant appointee bringing specific ESG expertise to the Board. Accordingly, Rosalind Kainyah was recruited and joined the Board on 1 January 2022. The Nomination Committee considers the size and composition of the Board to be appropriate to the Group's business and strategy but would continue to benefit from increased diversity.

The Non-Executive Directors constructively challenge management proposals where appropriate and carefully monitor management performance and reporting on an ongoing basis. The Company has both a Chairman and a Group Chief Executive.

There is a clear division of responsibilities, which has been agreed by the Board, and a summary of their respective roles is described below.

### Role of the Chairman

- Responsible for leading the Board, which includes the operation of the Board's overall procedures.
- Providing a forum for constructive discussion and ensuring receipt of clear and timely information.
- Overseeing Corporate Governance matters.
- Leading the performance evaluations of the Group Chief Executive, the Non-Executive Directors and the Board.

The Chairman, in conjunction with the Group Company Secretary, ensures that Directors receive a full, formal and tailored induction to the Group and ongoing training as relevant.

### Role of the Group Chief Executive

- Leading the development and implementation of the Group's strategy.
- Communicating with shareholders and other stakeholders.
- Responsible for the day-to-day management of the Group's businesses and reporting on their progress to the Board.
- Leading the Group Executive Committee.

The Group Chief Executive is assisted in meeting his responsibilities by the Group Executive Committee.

### Role of the Board

- Setting the long-term objectives and commercial strategy.
- Oversight of the management of discover!E.
- Review of the KSI and KPIs.
- Review of acquisitions and corporate transactions.
- Recommending or declaring dividends.
- Approval of financial statements, business plans, financing and treasury matters.
- Approval of major capital expenditure and commitments.
- Maintaining sound internal controls and risk management systems.
- Review of the Group's overall corporate governance.
- Any litigation of a material nature.

As set out on the following page, certain matters are delegated to the Group Executive Committee and to the Audit and Risk, Remuneration, Nomination and Sustainability Committees.



## Governance framework

### The Board

#### Chaired by Malcolm Diamond

Meets a minimum of six times a year.

Accountable to shareholders for the long-term success of the Group. This is achieved via a clear division of responsibilities between the Chairman and Group Chief Executive, the setting of strategic aims and ensuring that the necessary resources are in place.

### Nomination Committee

#### Chaired by Malcolm Diamond

The Nomination Committee regularly reviews the structure, size and composition of the Board and its Committees. It identifies and nominates suitable candidates to be appointed to the Board (subject to Board approval) and considers diversity, culture, talent and succession generally.

➤ Further information on the Nomination Committee is on pages 104 to 105

### Audit and Risk Committee

#### Chaired by Clive Watson

The Audit and Risk Committee has responsibility for overseeing and monitoring the Group's financial statements, accounting processes, audit processes (internal and external), and controls.

➤ Further information on the Audit and Risk Committee is on pages 97 to 103

### Remuneration Committee

#### Chaired by Tracey Graham

The Remuneration Committee reviews and recommends to the Board the framework and policy for the remuneration of the Chairman, the Executive Directors and the Group Executive Committee.

The Committee ensures that the remuneration policy of the Group reflects the Group's strategy.

➤ Further information on the Remuneration Committee is on pages 109 to 132

### Sustainability Committee

#### Chaired by Rosalind Kainyah

The Sustainability Committee reviews the Group's ESG plans and arrangements, seeking to align with best practice and underpinning the long-term sustainability of the Group.

➤ Further information on the Sustainability Committee is on pages 60 to 74

### Group Executive Committee

The Group Executive Committee comprises: Nick Jefferies, who is the Chairman of the Committee, together with Simon Gibbins, Greg Davidson, who is also the Secretary, Jeremy Morcom, Paul Hill and Martin Pangels.

The Committee typically meets 6 – 7 times a year and is responsible for the Group's day-to-day operations, for delivering results, and for driving growth and ensuring this is done in a sustainable and ethical manner.

## CORPORATE GOVERNANCE REPORT

### Composition, succession and evaluation

#### Current Composition

The biographies of the current members of the Board are set out on pages 82 and 83.

#### Work of the Nomination Committee

The Nomination Committee Report, which can be found on pages 104 to 105, describes the work of the Nomination Committee in ensuring that the Board continues to have the right mix of skills, knowledge and experience, and the process for ensuring that there is an effective process in place for succession planning. As noted in last year's Nomination Committee Report, the Board considered that steps should be taken to improve the diversity of the Board and wider Group. During the year, Rosalind Kainyah was appointed to the Board and the Board has adopted a revised Board Diversity Policy which includes targeting a minimum 40% female board representation (see [www.discoverIEplc.com](http://www.discoverIEplc.com) for more details).

#### Independence

The independence of the Non-Executive Directors is reviewed annually. The Board considers that the Non-Executive Directors bring strong independent oversight and continue to demonstrate independence. The Board recognises the recommended term for Non-Executive Directors as set out in the Code and is mindful of the need for suitable succession.

Bruce Thompson is the Senior Independent Director and is available to shareholders should they have concerns that cannot be resolved through other channels. Following Malcolm Diamond's retirement later in the year on 1 November 2022, Bruce Thompson will become Chairman and Tracey Graham will become Senior Independent Director.

#### Induction

All new Directors receive induction training on joining the Board and are expected to regularly update and refresh their skills and knowledge, with the Company providing the necessary resources, as required.

The induction programme includes meeting with the Group's senior management and visits to key locations, as well as a comprehensive briefing pack.

### Board composition

#### Gender diversity

Female (2)

**29%**

Male (5)

**71%**

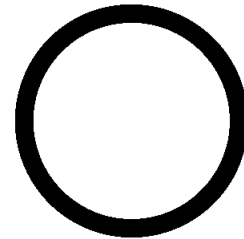

#### Independence

Executive (2)

**29%**

Non-executive (5)

**71%**

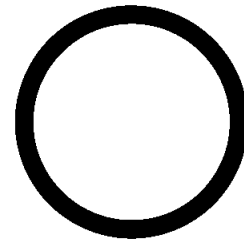

#### Board tenure

<1 year (1)

**14%**

>1 year (6)

**86%**

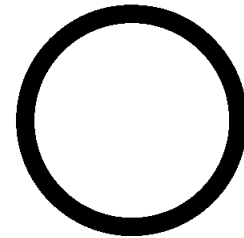

#### Ethnic diversity

Mixed/  
multiple ethnic group (1)

**14%**

White (6)

**86%**

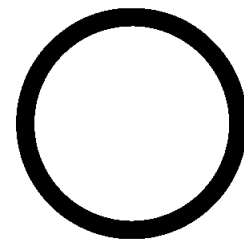



## Evaluation

In accordance with the Code, the Board and each of its Committees undertakes an evaluation each financial year. During the year ended 31 March 2022, the Company engaged Independent Audit Ltd, a global leader in Board evaluation processes, to lead an externally-facilitated review of the Board and its Committees. The Company has no other relationship with Independent Audit. An externally facilitated review will be conducted at least every three years. A summary of the process and findings are provided below.

### Step 1

An online questionnaire assessing the performance of the Board and each of its Committees was created by the external facilitator. This was circulated to all members of the Board and the respective Committees, along with regular internal and external attendees at meetings of the Board and each Committee. Responses to those questionnaires were submitted online to the external facilitator.

### Step 2

Two observers from the external facilitator attended a meeting of the Board and each Committee.

### Step 3

The external facilitator prepared a preliminary report, summarising both the responses received to the questionnaires, as well as the observations made by the attendees at the Board and Committee meetings. A meeting was then scheduled with the Chairman and Group Company Secretary to discuss that report.

### Step 4

The external report was then circulated to all members of the Board and discussed at the following Board meeting. Actions for improvement were decided upon.

A summary of the 2021 Board evaluation is detailed in the box opposite.

## Summary of the 2022

### Board evaluation

#### Board composition

The composition of the Board was positively rated but diversity and succession planning should be improved.

#### Board's expertise

The Board's understanding of the views and requirements of major investors and other stakeholders was rated positively.

#### Board dynamics

The interaction among and between Board members was rated highly, with there being a positive atmosphere and strong relationships, set in the context of proper and constructive challenge.

#### Management of meetings

The management of meetings and the structure of the Committees, together with Board support, was generally appropriate, with improvements possible in relation to the scheduling and prioritisation of agenda items.

#### Risk management

The effectiveness with which the Board takes risk into account when making decisions was positively rated. Further details on the Group's approach to risk are set out in the Risk Management section of this Annual Report on pages 42 to 59.

### Re-election

In accordance with the Code, all Directors stand for re-election annually at each AGM.



Corporate Governance

## CORPORATE GOVERNANCE REPORT

### Audit, Risk and Internal Control

The Strategic Report notes that delivering the Group's strategic priorities in a sustainable and responsible manner requires careful consideration to be given by the Board to the nature and level of risks that the Group should accept.

The Board's approach to risk generally, including the identification, management and mitigation of risks (including internal controls), is described in further detail in the following sections of this Annual Report and Accounts:

- Our approach to Risk Management is described on pages 42 to 46.
- The Group's Principal Risks and Uncertainties are set out on pages 54 to 59.
- Finally, the Audit & Risk Committee Report on pages 97 to 103 provides further details as to how the Committee provides oversight, and supports the Board, in relation to matters relating to audit, risk and internal controls generally.

### Remuneration

The Board's approach to remuneration is set out in the Remuneration Report (see pages 109 to 132). In its approach to remuneration, during the year ended 31 March 2022, the Company complied fully with the Code, with the exception of provision 38 of the Code (alignment of pensions). The Remuneration Committee has decided that employer pension contributions for any newly appointed Executive Directors shall be the same as those for the general UK workforce and that the contributions for the current Executive Directors will be aligned with the general workforce with effect from 1 January 2023.

### Approval

This Corporate Governance Report has been approved by the Board and signed on its behalf by

### Greg Davidson

Group General Counsel and Company Secretary

14 June 2022



## AUDIT AND RISK COMMITTEE REPORT



**“The Committee’s role is central in bringing together the Group’s risk management activities and control environment.”**

**Clive Watson**  
Chairman of the Audit Committee

Member	Member since
Clive Watson	2019
Tracey Graham	2017
Bruce Thompson	2019
Rosalind Kainyah	2022

The Group Company Secretary acts as Secretary to the Committee.

**Dear Shareholder,**

I am pleased to report on the activities of the Audit and Risk Committee (“the Committee”) during the year under review.

**Role of the Committee**

The Committee’s role is central in bringing together the Group’s risk management activities and control environment to ensure adherence to policies, the integrity of financial reporting and the maintenance of a strong risk-focused culture. Following recent and upcoming regulatory changes, this includes consideration and review of the Group’s exposure to climate-related risks and opportunities. As Chair of the Audit and Risk Committee, I attend the annual general meeting and make myself available for any shareholder questions within the Committee’s remit. The Committee oversees and reviews the management of risk, financial results, and the Group Internal Audit function.

**Key responsibilities of the Committee:**

- Consideration of the appropriateness of the accounting principles, policies and practices adopted in the Group’s accounts
- Review of external financial reporting and associated announcements to ensure they are fair, balanced and understandable

- Managing the appointment and remuneration of the Group’s external auditor, together with an assessment of the effectiveness and independence of the audit, including the policy on the award of non-audit services
- Initiating and supervising a competitive tender process for the external audit, as and when required
- Oversight of Group Internal Audit
- Ensuring the effectiveness of the Group’s risk management processes and internal controls
- Oversight and update of the Group Risk Register
- Oversight of the Group’s whistleblowing procedures in conjunction with the Board. If any issues are reported that require further investigation, this is typically conducted by the Group Internal Audit function, which reports back to the Committee as to their findings and whether any further action is necessary or desirable. During the year a small number of reports were made, with the majority proving to be routine HR matters. None of the matters reported were found to be a cause for concern.
- Monitoring compliance with the UK Corporate Governance Code

## AUDIT AND RISK COMMITTEE REPORT

### Meetings

During the year, the Committee met three times and also met privately with the external auditor. The Committee comprised the people shown in the table on page 97, all of whom are Non-Executive Directors.

In addition to the Committee members, the Group Finance Director, representatives from the external auditor, the Head of Risk and Internal Audit, the Group Risk and Internal Audit Manager and the Group Financial Controller attended these meetings by invitation. As Chair of the Committee, I maintain direct communication with the external auditor and the Head of Risk and Internal Audit, independently of the management of the Company.

Meetings of the Committee are scheduled so as to ensure the Committee is informed fully, and on a timely basis, on areas of significant risks and judgement. The Committee also received sufficient, reliable and timely information from management on significant changes to financial accounting standards and reporting requirements, regulatory and governance changes and developments concerning risk management, fraud prevention and detection, and cyber security. As Chair of the Committee, I report to the Board on any significant matters arising from the activities of the Committee.

The Board is satisfied that the members of the Committee have both recent and relevant experience (as set out on pages 82 and 83) and that, therefore, the Committee as a whole has competence in the sector in which the Group operates. The Committee is satisfied that the Group's executive compensation arrangements do not prejudice robust controls and good stewardship.

### Committee activities during FY 2021/22 and FY 2022/23 to date

#### May 2021

- Reviewed the results of the external audit of the FY 2020/21 Annual Report and Accounts
- Reviewed the going concern and viability statements
- Reviewed the FY 2020/21 Annual Report and Accounts including assessing and confirming that the Report was fair, balanced and understandable
- Assessed and agreed the independent status of the external auditor
- Discussed the overall adequacy and effectiveness of the Group's internal controls including reviewing the Group Internal Audit function's annual opinion on the Group's control framework

- Reviewed and approved the internal audit charter
- Half yearly review of the Group Risk Register, including agreeing key risks for inclusion in the FY 2020/21 Annual Report and Accounts

#### November 2021

- Reviewed half year results and judgemental accounting areas
- Reviewed regulatory updates
- Reviewed a high level approach to address the requirements for a UK Sarbanes-Oxley style regime, to strengthen the internal controls over financial reporting, included within the Department for Business, Energy & Industrial Strategy's proposals *Restoring trust in audit and corporate governance*
- Half yearly review of the Group Risk Register including, in particular, subsidiary risk reporting
- Reviewed proposed enhancements to the Group's Anti-Bribery Programme, including a policy review and the selection of a learning management system to facilitate Group-wide online training
- Reviewed and approved the internal audit charter

#### January 2022

- Reviewed the external audit planning report for FY 2021/22 Annual Report and Accounts (including review and approval of audit scope and fees)
- Agreed a risk management and internal audit programme and resource requirements in detail for FY 2022/23, and at a high level for the following three years

#### May 2022

- Reviewed the results of the external audit of the FY 2021/22 Annual Report and Accounts
- Reviewed the going concern and viability statements
- Reviewed the FY 2021/22 Annual Report and Accounts including assessing and confirming the changes in presentation of the Consolidated Statement of Profit and Loss (see Note 2 to the Financial Statements) and that the Report was fair balanced and understandable
- Assessed & agreed the independent status of the external auditor
- Discussed the overall adequacy and effectiveness of the Group's internal controls, including reviewing the Group Internal Audit Function's annual opinion on the Group's control framework



- Half yearly review of the Group Risk Register, including agreeing key risks for inclusion in the FY 2021/22 Annual Report and Accounts

#### Standing items

- Update on internal audits conducted and progress with management's implementation of actions
- Update on alignment of newly acquired businesses to group policies and procedures
- Update on risk management projects
- Update on Whistleblowing reports

After each meeting of the Committee, the Chair of the Committee reports to the Board, to enable the Board to discharge its responsibilities.

#### Fair, balanced and understandable

The Committee has, at the request of the Board, reviewed this year's Annual Report and Accounts to assess whether it presents a fair, balanced and understandable view of the Company's position and prospects. The Committee's review took account

of the process by which the Annual Report and Accounts is prepared, which includes analysis of changes to applicable reporting requirements and standards, and a robust schedule of review and verification by senior management and external advisers to ensure disclosures are accurate. The Committee is satisfied that, taken as a whole, the Annual Report and Accounts is fair, balanced and understandable and provides the information necessary for shareholders to assess the Group's position and performance, business model and strategy and has advised the Board accordingly.

#### Significant matters considered and decisions taken

As part of the monitoring of the integrity of the financial statements, the Committee assesses whether suitable accounting policies have been adopted and whether management has made appropriate estimates and judgements. The viewpoint of the external auditor is sought when undertaking these assessments.

During the year, the Committee's review of other significant accounting and financial reporting issues included a focus on the key areas outlined as follows:

<b>Impairment of goodwill</b>	A consideration of the carrying value of goodwill and the assumptions underlying the impairment review. The judgements in relation to goodwill impairment largely relate to the assumptions underlying the calculations of the recoverable amount of the business unit being tested for impairment, primarily the achievability of long-term business plans and macroeconomic assumptions underlying the valuation process. The assumptions are sensitised to ensure that there is adequate headroom between the recoverable amount and the carrying value of the business being tested for impairment.  Specifically, this included a review of any businesses not performing in line with expectations, to assess any potential impact on the carrying value of goodwill.
<b>Accounting for acquisitions and disposals</b>	A review of the accounting for the acquisitions of CPI, Antenova and Beacon, and the disposals of Acal BFi and Vertec SA, during the year, including the appropriateness of the assumptions used in assessing the fair value of assets and liabilities acquired and disposed.
<b>Presentation of discontinued operations</b>	A review of the appropriateness of presenting the results of the disposed businesses during the year as discontinued operations.
<b>Change in operating segments</b>	Review the appropriateness of the revised reportable operating segments. Following the exit from its distribution business the Group has been divided into two operating segments, the Magnetics & Controls division ("M&C") and the Sensing & Connectivity division ("S&C").
<b>Valuation of the legacy defined benefit pension scheme</b>	A review of the appropriateness of the assumptions used in the valuation of the legacy defined benefit pension scheme under IAS 19 – Employee Benefits.



## AUDIT AND RISK COMMITTEE REPORT

<b>The recognition and valuation of judgemental provisions</b>	A determination of the appropriateness of the assumptions used in the recognition and valuation of judgemental provisions which relate mainly to onerous contracts, inventory, severance indemnities, acquisition earn-out arrangements, long-term incentive plans, restructuring and integration.
<b>Presentation of underlying profit adjustments</b>	A review of the appropriateness of items disclosed as exceptional items and acquisition-related costs (including amortisation of acquired intangibles and acquisition expenses) in the Supplementary income statement information and notes to the Group financial statements, in line with the Group's stated policy.
<b>Climate related financial disclosures</b>	An evaluation of impact of climate change on the Group financial statements in accordance with the TCFD framework. The process has involved a review of all balance sheet line items and future cash flows, to identify if any of these items are expected to be materially impacted in a negative or positive way by weather, legislative, societal or revenue/cost changes.
<b>Going Concern and Viability</b>	A review of the paper prepared by management on the Group's going concern and viability assessment. This included a review of underlying forecast and cash flow assumptions and downside scenarios.

The Committee was satisfied that each of the matters set out above had been fully and adequately addressed by the Executive Directors, appropriately tested first by the Committee and then reviewed by the external auditor, and that the disclosures made in this Annual Report and Accounts were appropriate.

In respect of each significant matter reviewed by the Committee, the Committee considered the assumptions made, the reasonableness of judgements in their context, and how such matters have been presented. The Committee evaluated and challenged each of these to ensure that the Annual Report and Accounts is complete and accurate in all material respects.

### Tax and Treasury

The Committee meets annually with the Head of Tax and the Group Treasurer to review the key tax and financing matters affecting the Group and to understand the areas of focus in the forthcoming year.

### Risk management and internal controls

The Board has overall responsibility for the Group's risk appetite and risk management. This includes determining the nature and extent of the risks it is willing to take in achieving the Group's strategy and objectives. The Board is ultimately responsible for the effectiveness of the risk management strategy and framework, and internal controls systems.

Oversight of risk management is undertaken by the Committee, in accordance with its terms of reference. In order to ensure the effectiveness of the risk management and internal control systems, the Committee undertook a number of key activities during the year, including:

- Consideration of the risk management activities during the year (including particular focus on specific areas of cyber security anti-bribery, conformance of suppliers with the Group's code of conduct and financial controls)
- Review of risk management and reporting to ensure effectiveness and that the balance between risk and opportunity was in keeping with the Group's risk appetite
- Regular meetings with members of senior management and the Group Internal Audit function
- Review of reports on control matters and challenge of management's response to any matters raised
- Evaluation and challenge of the results and recommendations of audits undertaken by the Group Internal Audit function and the external auditor
- Review of the resource requirements of the Group Internal Audit function
- Review of the annual Audit and Risk Committee agenda.



### Review of Internal Controls

The Group's finance department includes a separate Group Internal Audit function. This is led by the Head of Risk and Internal Audit who is part of the Group management team and reports to the Group Financial Director and, independently, to me, as Chair of the Committee.

### Internal Audit

The Group Internal Audit function's primary purpose is to provide risk-based and independent assurance, advice and insight to help improve all aspects of the organisation's governance and system of internal control, including management of risk. The remit of the internal audit function covers discoverIE Group plc and all of its subsidiaries. Resource in the function increased from two to three staff during FY 2021/22, plus support from the Group Projects Manager, external consultants and outsourced providers as deemed necessary. Further details on the operation of the Group Internal Audit function can be found in the Risk Management section on pages 42 to 46.

The Audit and Risk Committee has overall responsibility for reviewing the effectiveness of the Group's internal control framework and the Group Internal Audit function. As part of this, we ensure that the Group Internal Audit function has unrestricted scope, the necessary resources, and appropriate access to information, to enable it to perform its function effectively. The suitability of resources available to the Group Internal Audit function was considered in the year. The Committee also reviews regular updates on internal audit work carried out and the actions taken by management to implement the recommendations of internal audit reviews.

A programme of internal audit activities has been completed during the year. The scope of work carried out by the Group Internal Audit function generally focuses on the internal financial and operational controls within each business, particularly in recently acquired businesses. Further internal audit work is outsourced to external providers, where appropriate.

While no system of controls can provide absolute assurance against material misstatement or loss, the Group's systems are designed to manage, rather than eliminate, the risk of failure to achieve business objectives and provide reasonable, and not absolute, assurance against material misstatement or loss. As part of the annual review of the effectiveness of the Group's internal controls, the Committee, on behalf of the Board, has regard to the design of the risk management framework including the three lines of defence model, the significance of the risks involved, the likelihood and severity of an event occurring and the costs associated with any relevant controls. The formal Annual Opinion for FY 2021/22 issued by the Group Internal Audit function was reviewed by the Committee, concluding that there were no material failings or weaknesses identified in the Group's internal control systems.

## AUDIT AND RISK COMMITTEE REPORT

The principal components of the Group's systems of control are:

- a well defined organisational structure with short and clear reporting lines
- recruitment of high-quality staff
- an ongoing process for the identification, regular review and management of the principal risks and issues affecting the business, both at Group and operating levels
- in-house and outsourced internal audit activities
- an ongoing review of regulatory compliance
- a regular review of the principal suppliers and customers of the Group, and how each impacts upon the Group's business
- a comprehensive planning process, which starts with a strategic plan and culminates in an annual budget and a long-term plan
- regular rolling forecasting throughout the year of orders, sales, profitability, cash flow, working capital and balance sheets
- a regular review of actual performance against budget and forecasts
- clearly defined procedures for the authorisation of major new investments and commitments
- a requirement for each operating company to maintain a system of internal controls appropriate to its own local business environment.

The Finance team is responsible for producing financial information that is timely, accurate and in accordance with applicable laws and regulations. In addition, it is responsible for the distribution of financial information, both internally and externally. Key financial and operational performance is reported on a timely basis and measured against both the Board-approved budget, management's rolling forecasts and comparable information from prior periods. A review of the financial statements is completed by management to ensure that the financial position and results of the Group are appropriately reflected. All financial information published externally by the Group is approved by the Board.

The above procedures apply to discoverIE Group plc and all of its subsidiary companies.

### External audit

The Committee is responsible for managing the relationship with the Group's external auditor on behalf of the Board including their appointment, remuneration, independence and performance.

During the year the Committee's activities in respect of external audit were as follows:

- considering the re-appointment of the external auditor
- considering and approving the audit approach and scope of the audit undertaken by PricewaterhouseCoopers ("PwC") and the related fees
- agreeing reporting materiality thresholds
- reviewing reports on audit findings
- considering and approving letters of representation issued to the external auditor
- considering the independence of the external auditor.

### Audit performance and effectiveness

The performance and effectiveness of the external auditor and related audit is reviewed annually by the Committee. This covers the robustness of the audit at both a Head Office and entity level.

The review covers the following:

- Robustness of the audit plan and, in particular, the identification of significant risks
- Execution of the above plan, including the external auditor's ability to challenge management on key accounting judgements and assumptions adopted
- Ensuring the external auditor demonstrates a deep and thorough knowledge of the business to enable them to reach appropriate conclusions on key accounting judgements
- Quality of reports provided to the Committee
- Communication between the external auditor and the Committee
- Feedback from management on the quality of the audit team
- Professional scepticism of the external auditor.



The Committee concluded that the audit team had the necessary professionalism, experience and understanding of the business to carry out a thorough and robust audit. As a result, the performance of PwC was considered satisfactory.

The Group has complied with the provisions of the Competition and Market Authority (CMA) Order, issued by the CMA in September 2014, for "The Statutory Audit Services for Large Companies Market Investigation (Mandatory Use of Competitive Tender Processes and Audit Committee Responsibilities)".

### External Auditor independence

The Committee believes that the provision of non-audit services to the Company is closely related to external auditor independence and objectivity. The Committee recognises that the independence of the external auditor may risk becoming compromised if it also acts as the Company's consultant and adviser to any material extent.

The Committee accepts that certain work of a non-audit nature is best undertaken by the external auditor. The Committee reviewed its policy on the provision of non-audit services during the year to ensure that there is no likelihood of any impairment of external auditor independence or objectivity.

The non-audit services that were provided by the external auditor during the financial year, the fee for which totalled £4,139 (0.25% of the audit fee) (FY 2020/21: £8,000: 0.6%), were not considered to adversely impact the independence of the external auditor, were in line with Group's policy on non-audit services and were permissible under Ethical Standards.

The Company last undertook a tender for external audit services in 2017 which led to the appointment of PwC which conducted its first audit of the Group for the year ended 31 March 2018. There are no contractual obligations restricting the Committee's choice of external auditors. The external auditors are required to rotate the audit partner at least every five years and the current lead audit partner, Chris Hibbs, was assigned to the discoverIE audit in 2021. The Committee recommended to the Board that it proposes to shareholders that PwC be re-appointed at the annual general meeting.

### Additional key areas of focus in 2022/23

- Continue to assess progress against additional measures being rolled out following cyber risk review
- Further assessment of exposure to ESG-related risks including to climate-related risks and opportunities
- Review the accounting for new acquisitions
- Monitor the development and assess the impact of the UK's audit and governance reform proposals as set out in the BEIS consultation published on 18 March 2021

### Terms of reference

The Committee's terms of reference are available upon request and are on the Company's website: [www.discoverIEplc.com](http://www.discoverIEplc.com).

### Clive Watson

Chairman of the Audit and Risk Committee

14 June 2022

## NOMINATION COMMITTEE REPORT



**“The Committee helps ensure that the Group has strong and responsible leadership, aligned to our purpose and culture.”**

Malcolm Diamond MBE  
Chairman of the Nomination Committee

Member	Member since
Malcolm Diamond	2017
Tracey Graham	2018
Nick Jefferies	2009
Rosalind Kainyah	2022
Bruce Thompson	2019
Clive Watson	2021

The Group Company Secretary acts as Secretary to the Committee.

### 2021/22 key achievements

- Recommended to the Board the appointment of Rosalind Kainyah, which was duly approved
- Identification of priorities for the coming year

### Key areas of focus in 2022/23

- Increasing diversity across the Group
- Appointment of a new Non-Executive Director given my planned retirement in November 2022
- Continued evaluation of knowledge and skills

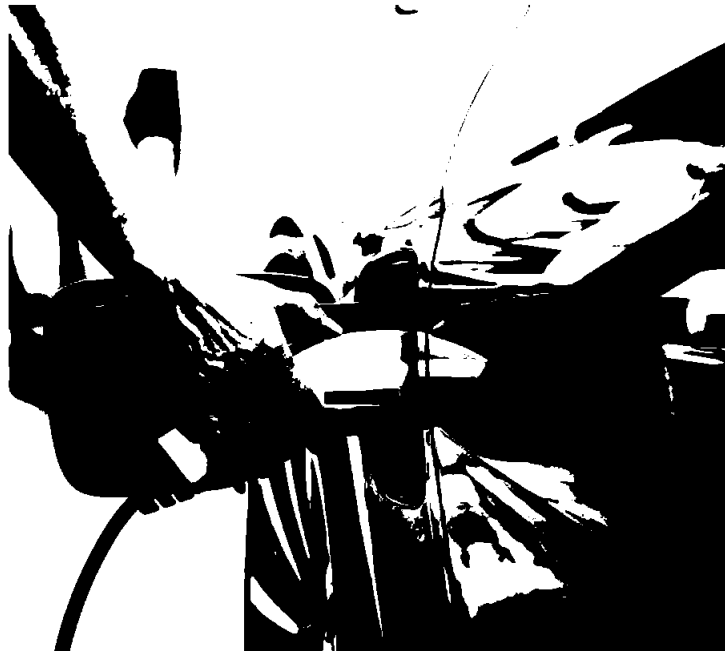



### Dear Shareholder,

During the year, the Committee met twice, with all Committee members attending and participating in a separate evaluation process which identified areas for improvement, especially in relation to succession planning and diversity. The Committee's recommendations were made after careful consideration of the independence, performance and ability to continue to contribute to the Board of the relevant people, in the light of the knowledge, skills, commitment and experience required.

### Composition

The majority of the Committee members are independent Non-Executive Directors. During the year under review, the Committee was chaired by me, with Tracey Graham, Bruce Thompson, Clive Watson, Rosalind Kainyah (with effect from January 2022) and Nick Jefferies as Committee members.

### Key responsibilities

The Committee's key duties are:

- To review the structure, size and composition (including the skills, knowledge and experience) of the Board and to recommend changes where appropriate.
- To consider succession planning for the Directors and the right balance of skills, knowledge, experience and diversity on the Board.
- To identify and nominate candidates to fill Board vacancies, having previously prepared a description of the role and capabilities required for a particular appointment.
- To review the leadership needs of the organisation, both executive and non-executive.
- To make recommendations to the Board on the reappointment of any Non-Executive Director at the conclusion of their specified term of office and on appointments to the Audit and Risk and Remuneration Committees.
- To review, as part of the annual assessment exercise, the time commitment of the Non-Executive Directors to the role and to their external appointments.

### Appointment of Directors

The Committee's principal role is to make recommendations to the Board on suitable candidates to fill Board vacancies, as and when they arise, or when other changes or appointments may be desirable. In managing this process, the Committee takes into account the Board's existing

balance of skills, knowledge and experience and has due regard for diversity. Unless the appointment is as an Executive Director, for which a suitable candidate is available from within the Group, the Committee will create a short-list of suitable candidates for final selection by the Committee. References from appropriate third parties will then be taken on the prospective director. Candidates meet all members of the Committee, which then makes recommendations to the Board. Adopted practice is for all members of the Board to meet with the relevant candidate before an appointment is made.

As noted earlier in this Annual Report and Accounts, Bruce Thompson will succeed me as Chairman of the Board following my retirement on 1 November 2022. Bruce's appointment as Chairman followed a rigorous and detailed process conducted by the Committee and assisted by Russell Reynolds, a leading advisory firm that specialises in the appointment of Board members for listed companies. Russell Reynolds has no connection to the Company, or to any individual director, other than assisting with recruitment. Tracey Graham chaired the Nomination Committee when it was dealing with the appointment of a successor to the chairmanship. Bruce Thompson absented himself from these discussions.

### Diversity and Succession planning

The Board is committed to a culture which attracts and retains talented people and to ensure that a proper process exists for succession planning for the Board and senior management.

The Company's Board Diversity Policy can be found on the Company's website [www.discoverIE plc.com](http://www.discoverIE plc.com). Please see page 74 of the Sustainability Report for a summary of the Group's current gender diversity and page 94 of the Corporate Governance Report for the current Board composition.

### Terms of reference

The Committee's terms of reference are available upon request and are on the Company's website: [www.discoverIE plc.com](http://www.discoverIE plc.com)

### Malcolm Diamond MBE

Chairman of the Nomination Committee

14 June 2022



## DIRECTORS' REPORT

The Directors' report for the financial year ended 31 March 2022 is set out below. Certain matters required to be included in the Directors' report are included in the Strategic report, as the Board considers them to be of strategic importance, as follows:

Disclosure	Location
<b>Future business developments</b>	Throughout the Strategic Report (page 02 to 81)
<b>Risk management</b>	Risk management and principal risks and uncertainties (pages 42 to 59)
<b>Employee engagement</b>	Please see pages 75 and 90.
<b>Greenhouse gas emissions</b>	Sustainability Report (pages 60 to 74)
<b>Stakeholder engagement</b>	Please see pages 75 to 76

The Group's policies and processes for managing its capital, its financial risk management objectives, its financial instruments and hedging activities and exposure to credit and liquidity risk are disclosed in note 27 to the Group financial statements on pages 195 to 197.

Both the Directors' report and the Strategic Report have been drawn up in accordance with English company law. The liabilities of the Directors in connection with that report shall be subject to the limitations and restrictions provided by such law.

### Financial results and dividends

The audited consolidated financial statements set out the results of the Group for the financial year to 31 March 2022 and are shown on pages 146 to 212. The key strategic and performance indicators of the business are set out in the Strategic report on pages 02 to 81.

The Directors recommend a final dividend of 7.45p per share (2020/21: 7.0p) which, together with the interim dividend of 3.35p per share (2020/21: 3.15p), makes a total dividend for the year of 10.8p per ordinary share (2020/21: 10.15p). Subject to approval by shareholders of the recommended final dividend, the dividend award to shareholders for 2021/22 will total £10.3m (2020/21: £9.0m). If approved, the Company will pay the final dividend on 2 August 2022 to shareholders on the register of members at 24 June 2022.

The Board believes that, as an acquisitive growth company, maintaining a progressive dividend policy, with the long term dividend covered over three times by underlying earnings, is appropriate to enable both dividend growth and a higher level of investment from internally generated resources.

### Directors

Board membership and biographical details of the Directors are on pages 82 and 83 and are incorporated by reference.

Copies of Executive Directors' service contracts are available to shareholders for inspection at the Company's registered office and at the annual general meeting. Details of the Directors' remuneration and service contracts and their interests in the shares of the Company are included in the Directors' remuneration report which is set out on pages 109 to 132.

### Powers of the Directors

The Board of Directors is responsible for the management of the business of the Company and may exercise all the powers of the Company, subject to the Company's Articles of Association (the "Articles"), the Companies Act 2006 and any directions given by the shareholders by special resolution. The Articles may be amended by a special resolution of the Company's shareholders.

### Appointment and replacement of Directors

The Board can appoint a Director but anyone so appointed must be elected by an ordinary resolution at the next general meeting. All Directors offer themselves for re-election at each annual general meeting.

### Directors' conflicts of interest

The Company has procedures in place for managing conflicts of interest. Should a Director become aware that they, or any of their connected parties, have any interest in an existing or proposed transaction with discoverIE, they should notify the Board in writing or at the next Board meeting. Internal controls are in place to ensure that any related party transactions involving Directors, or their connected parties, are conducted on an arm's length basis. Directors have a continuing duty to update any changes to these conflicts.

### Directors' indemnity

The Articles of the Company contain an indemnity in favour of the Directors, which is a Qualifying Third Party Indemnity within the meaning of s.234 of the Companies Act 2006. This was in force throughout the year ended 31 March 2022 and at the time of the approval of this Annual Report and Accounts. Directors of subsidiary undertakings are also subject to this Qualifying Third Party Indemnity.

In addition, each Director of the Company has entered into a Deed of Indemnity with the Company, which operates only in excess of any right to indemnity that a Director may enjoy under any such other indemnity or contract of insurance. The Company has also arranged appropriate insurance cover in respect of legal action against its Directors and officers.

### Share capital

As at 31 March 2022, the Company's issued share capital consisted of 95,456,109 ordinary shares of 5p each (no shares are held in treasury).

Details of movements in the Company's issued share capital can be found on page 199 in note 30 to the Group financial statements.

### Restrictions on transfer of securities in the Company

There are no restrictions on the transfer of securities in the Company, except that certain restrictions may from time to time be imposed by laws and regulations (for example, insider trading laws such as the Market Abuse Regulation) and pursuant to the Listing Rules of the Financial Conduct Authority, whereby certain employees of the Company require the approval of the Company to deal in the Company's ordinary shares. The Company is not aware of any agreements between holders of securities that may result in restrictions on the transfer of securities.

### Rights and obligations attaching to shares

Subject to the Articles, the Companies Act 2006 and other shareholders' rights, shares in the Company may be issued with such rights and restrictions as the shareholders may by ordinary resolution decide, or, if there is no such resolution, as the Board may decide, provided it does not conflict with any resolution passed by shareholders.

The rights attached to any class of shares can be amended if approved, either by 75% of shareholders holding the issued shares in the class by amount, or

by special resolution passed at a separate meeting of the holders of the relevant class of shares.

Every member and every duly appointed proxy present at a general meeting or class meeting has, upon a show of hands, one vote and every member present in person or by proxy has, upon a poll, one vote for every share held.

No person holds securities in the Company carrying special rights with regard to control of the Company.

### Substantial shareholdings

As at 31 March 2022, the Company had been notified of, or was aware of, the following major shareholdings equal to, or greater than, 3% of the issued share capital of the Company:

abrdrn	11,893,559	12.46%
Blackrock	6,715,225	7.03%
Kempen Capital Management NV	5,040,000	5.28%
Impax Asset Management	4,318,765	4.52%
Montanaro Asset Mgt	3,945,000	4.13%
Legal & General Investment Mgt	3,407,972	3.57%
Wasatch Global Investors	3,149,817	3.30%
Swedbank Robur	3,073,873	3.22%

As at 10 June 2022, the Company had been notified of, or was aware of, the following shareholders holding 3% or more of the issued share capital of the Company:

Shareholder	Holdings of ordinary shares (5p)	% of issued share capital
abrdrn	12,082,475	12.66%
Blackrock	6,715,225	7.03%
Kempen Capital Management NV	5,070,000	5.31%
Impax Asset Management	4,367,430	4.58%
Montanaro Asset Mgt	3,795,000	3.98%
Legal & General Investment Mgt	3,412,037	3.57%
Wasatch Global Investors	3,402,293	3.56%
Swedbank Robur	3,073,873	3.22%



## DIRECTORS' REPORT

### Authority to purchase own shares

At the annual general meeting held on 29 July 2021, shareholders authorised the Company to purchase in the market up to 10% of its issued share capital (8,945,591 ordinary shares) and, as at 31 March 2022, all of this authority remained in force and unused. This authority is renewable annually, and a special resolution will be proposed at the 2022 annual general meeting to renew it. The Directors will only purchase the Company's shares in the market if they believe it is in the best interest of shareholders generally.

### Change of control

Details of the Group's borrowing facilities are provided in the Finance review section of the Strategic report on page 40. These agreements contain a change of control provision, which may result in the facility being withdrawn or amended upon a change of control of the Group. The Group is party to a number of commercial agreements which, in line with industry practice, may be affected by a change of control following a takeover bid. There are no agreements between the Company and its Directors or employees providing for compensation for loss of office or employment which occurs because of a takeover bid.

### Political donations

There were no political donations during the year (FY 2020/21: nil).

### Auditor and disclosure of information to auditor

PricewaterhouseCoopers LLP have indicated their willingness to continue in office and a resolution to appoint them will be proposed at the annual general meeting. In the case of each Director in office as at the date of this report:

- so far as the Director is aware, there is no relevant audit information of which the Group and Company's auditors are unaware; and
- they have taken all the steps that they ought to have taken as a Director in order to make themselves aware of any relevant audit information and to establish that the Group and Company's auditors are aware of that information.

### Annual General Meeting

The Notice of the annual general meeting to be held at 11.30am on Thursday 28 July 2022 will be sent to shareholders separately from this report. The venue for the meeting is 2 Chancellor Court, Occam Rd, Guildford, Surrey, GU2 7AH. Details of the arrangements for that meeting will be as set out in the Notice for that meeting.

### Going concern

For the reasons explained in the Viability Statement on pages 52 and 53, the Directors continue to adopt the going concern basis in preparing this Annual Report and Accounts.

By order of the Board

### Greg Davidson

Group General Counsel & Company Secretary  
14 June 2022

2 Chancellor Court,  
Occam Road,  
Surrey Research Park,  
Guildford,  
Surrey GU2 7AH

Registered number: 02008246

## DIRECTORS' REMUNERATION REPORT



**“This has been an excellent year for performance and strategic progress.”**

**Tracey Graham**  
Chair of the Remuneration Committee

Member	Member since
Tracey Graham (Chair)	2016
Malcolm Diamond	2017
Bruce Thompson	2018
Clive Watson	2020
Rosalind Kainyah	2022

The Committee consults with the Group Chief Executive who may attend meetings by invitation of the Committee Chair, although he is not involved in deciding his own remuneration. The Group Company Secretary acts as Secretary to the Committee.

### FY 2021/22 key achievements

- Received strong shareholder approval for our Directors' Remuneration Policy at the 2021 annual general meeting following consultation with the Company's largest shareholders
- Granting of LTIP awards under the new Remuneration Policy with the revised performance conditions
- Approval of bonus outcomes for 2020/21 performance, including management's proposed reductions to formulaic outcomes
- Considered the implications of the disposal of the distribution business for incentives
- Setting of appropriate incentive measures and targets for Executive Directors and senior management, including the introduction of a specific ESG component in the annual bonus for 2022/23
- A review of other remuneration-related items within the UK Corporate Governance Code and the latest views from investors and proxy voting agencies
- Oversight of wider workforce remuneration, including an increase to UK pension contribution rates
- Consideration of gender pay gap data

### Key areas of focus in FY 2022/23

- Review the competitiveness of remuneration for Executive Directors and senior management and its alignment with strategy
- Review of pay across the discoverIE workforce
- Set incentive targets and determine incentive outcomes for Executive Directors and senior management
- Keeping abreast of corporate governance and regulatory developments
- Monitoring of performance against all personal objectives, including in particular the sustainability/ ESG measures included in the objectives for the Executive Directors and Group Executive Committee



## DIRECTORS' REMUNERATION REPORT

### ANNUAL STATEMENT

Information not subject to audit

#### Dear Shareholder,

On behalf of the Board, it is my pleasure to present our Directors' Remuneration Report for the year ended 31 March 2022. This report comprises:

- This Annual Statement which summarises the work of the Remuneration Committee (the 'Committee') in FY 2021/22.
- The Directors' Remuneration Policy (the 'Policy') which sets the parameters for how our Directors are remunerated and which took effect from 29 July 2021, the date of its approval at our 2021 annual general meeting.
- The Annual Report on Remuneration which provides (i) details of the remuneration earned by Directors and the link between Company performance and pay in the year ended 31 March 2022 and (ii) how we intend to implement the new Policy in FY 2022/23.

At the 2021 AGM, we received clear support for our Directors' Remuneration Policy and I am grateful for the feedback received as part of the review process. During the last year, the focus shifted to implementing the policy and ensuring there is appropriate alignment between pay outcomes and performance.

#### Business performance and resulting remuneration outcomes for the year ending 31 March 2022

The Group has performed exceptionally well this year, with very strong financial performance, completion of the Group's long-term strategy to exit the distribution business through the disposals of both Acal BFi and Vertec SA, and good progress against ESG initiatives, including a 33% reduction in like-for-like carbon emissions intensity and completion of the first phase of solar panel installations in Sri Lanka. The Group also completed three acquisitions, further expanding its footprint outside Europe.

This has been a significant year of strategic progress and I would like to thank all of our staff globally for their tremendous efforts in what has been a very successful year for the Group.

#### Annual bonus for FY 2021/22

The annual bonus for both Executive Directors for FY 2021/22 was based on operating profit targets (60%), simplified working capital (24%) and non-financial objectives (16%).

Based on the strong performance as set out above, actual underlying operating profit of £41.4m was above the maximum target, performance against the Simplified Working Capital target exceeded maximum and non-financial objectives were determined to have been met in full. This results in an overall bonus payout of 100% of maximum for both directors.

The Remuneration Committee has considered carefully whether any adjustment is required to the formulaic outcomes to reflect the underlying financial and non-financial performance of the business. By way of context, the Executive Directors voluntarily reduced their bonus outcomes for performance in FY 2020/21 to reflect the impact of the pandemic on the business. However, this year, the Committee believes that the bonus outcome is a fair reflection of the very strong performance of the business during the year and its strategic progress.

In line with the remuneration policy, 20% of the bonus will be delivered in deferred share awards. Further details of the bonus for FY 2021/22 are set out in the Annual Report on Remuneration.

#### 2019 long term incentives vesting

The Group Chief Executive and Group Finance Director received awards under the LTIP on 30 April 2019 that were based on absolute TSR, relative TSR and EPS performance criteria.

- Relative TSR – discoverIE delivered a TSR of 104.5% over the three-year period to 31 March 2022 which ranked in the top 10% of the TSR peer group (for the second consecutive three-year cycle), thereby achieving this element in full.
- Absolute TSR – discoverIE's TSR of 104.5% over the period was above CPI + 30%, thereby achieving this element in full.
- EPS – EPS grew by 44%, which was in excess of the maximum target. Acal BFi was included in both the base year and in the final year to the date of disposal (11 months).

This performance has resulted in all of the LTIP awards granted in April 2019 vesting in full. The Committee believes this vesting outcome is warranted given the exceptional share price and earnings growth over the three-year period. Therefore, no discretion has been applied to adjust the formulaic outcomes. These shares will be subject to a two-year holding period before they become exercisable.



### Application of policy in 2023

- **Base salary:** The Remuneration Committee has reviewed base salary levels across the business in the context of the current high inflationary environment. The Group Chief Executive's base salary will be increased by 4% in line with increases of c.4%-5% across the UK employee group. The Group Finance Director's base salary will be increased by 2.5% and his pension will increase by 1.5% in line with the general UK workforce contribution rate. Base salary increases in the rest of the business will be higher, with up to 15% increases in some territories.
- **Pension:** As outlined in last year's report, the Group Chief Executive's pension contribution will reduce from 15% of salary to the UK workforce rate from 1 January 2023.
- **Bonus:** The bonus opportunity will be 150% of salary for the Group Chief Executive and 125% of salary for the Group Finance Director, in line with policy. The bonus measures and weightings for financial measures will remain unchanged for FY 2022/23 with 60% based on operating profit targets, and 24% on Simplified Working Capital. The non-financial objectives (16%) element will be split into two equal parts with 8% based on strategic objectives and the other 8% on ESG-related objectives.
- **LTIP:** In line with our policy, the award to the Group Chief Executive will be 175% of salary and 160% of salary for the Group Finance Director. The LTIP measures will continue to be split equally between relative TSR and EPS growth. The EPS growth targets have been increased for the second consecutive year so that the threshold and maximum targets are 5%p.a. and 13%p.a. respectively. Vesting of the EPS element shall also be subject to an underpin requiring the Committee to be satisfied with the Group's annual rate of return on capital employed ("ROCE") over the measurement period. Further details of the approach for 2022 can be found in the Annual Report on Remuneration.

The Remuneration Committee considered the appropriate LTIP grant level for FY 2022/23 and believes granting at 175% of salary and 160% of salary for the Group Chief Executive and Group Finance Director is appropriate, having taken into account the following factors:

- i. The EPS targets have been made tougher compared with previous grants and full vesting will only occur if EPS grows by more than 44% over the three-year period. Furthermore, as set out in our March 2022 investor presentation, our mid-range targets attached to the delivery of our Key Strategic Indicators have increased, supporting our ambition of significantly growing operating margin and earnings.
- ii. The grant level is in line with and, in the case of the Group Finance Director, below the limit approved by shareholders at the 2021 annual general meeting. In the first year of the new Policy, the Committee granted at below the approved policy levels, demonstrating a prudent approach to adopting the higher shareholder approved limit.
- iii. The proposed grant levels for FY 2022/23 reflect the strong performance of the business and executives over the last year as set out in the business performance section above and are in line with those in businesses of a similar size to discoverIE.

The Remuneration Committee will consider the share price at the time of grant when finalising award levels, expected to be in June 2022. Whilst the Committee recognises that the prevailing share price at the time of writing is lower than the share price at the time of last year's award, when considered over a longer period, the prevailing price is significantly higher than the prices used to determine LTIP levels in the four prior years, 2017 to 2020.

There will be a single advisory vote at the AGM on 28 July 2022 to approve this directors' remuneration report. I hope you find the information in the report clear and are able to support this resolution. If you have any questions on our policy or on this report then please contact me via the Company Secretary.

### Tracey Graham

Chair of the Remuneration Committee

14 June 2022



Corporate Governance

## DIRECTORS' REMUNERATION REPORT

### Remuneration at a glance

When determining the Remuneration Policy, the Committee has ensured that the Directors' Remuneration Policy and practices are consistent with the six factors set out in Provision 40 of the Corporate Governance Code:

#### CLARITY

Our Directors' Remuneration Policy is well understood by our senior executive team and the Company invited its principal shareholders and shareholder representative groups to consult on the updated Remuneration Policy and received good feedback. This report sets out the remuneration arrangements for the Executive Directors in a clear and transparent way.

#### SIMPLICITY

The Committee is mindful of the need to avoid overly complex remuneration structures which can be misunderstood and deliver unintended outcomes. Therefore, a key objective of the Committee is to ensure that our Directors' Remuneration Policy and practices are straightforward to communicate and operate. The Committee's approach to performance measures has always been that they must be understandable for participants in the schemes in order to ensure they are effective.

#### RISK

Our Directors' Remuneration Policy has been designed to ensure that inappropriate risk-taking is discouraged, including the use of a blend of financial, non-financial and shareholder return targets. Shares play a significant role in our incentive arrangements; this includes the deferral under the annual bonus; malus/clawback provisions operate within our incentive plans.

#### PREDICTABILITY

Our incentive plans are subject to individual caps, with our share plans also subject to standard dilution limits. The potential value and composition of the Executive Directors' remuneration packages at below threshold, target and maximum scenarios are provided in the relevant policy.

#### PROPORTIONALITY

There is a clear link between individual awards, delivery of strategy and our long-term performance. The Committee has discretion to override formulaic results to ensure that they are appropriate and reflective of overall performance.

#### ALIGNMENT TO CULTURE

The variable incentive schemes and performance measures are designed to be consistent with the Group's purpose, values and strategy.

### Executive Directors

In this section, we show the link between corporate performance for the year under review and the remuneration outcomes for the Executive Directors. The key features of the Executive Directors' remuneration for the year ended 31 March 2022 are also shown.

#### Corporate performance for the year

Revenue

**£379.2m**

Underlying Operating Profit

**£41.4m**

Underlying EPS

**29.4p**

#### Remuneration outcomes for the Executive Directors for the year ended 31 March 2022

	Nick Jefferies £000		Simon Gibbins £000	
Salary FY 2021/22	490		326	
Bonus (£k and as % of salary)	735	150%	407	125%
Taxable benefits	11		12	
Pension benefits/ allowance	74		21	
Value of LTIP vesting	1,270		703	
Single figure of total remuneration	2,580		1,469	

The annual bonus for the year ending 31 March 2022 was based on the achievement against financial and non-financial measures. The bonus outcomes for the year were 150% of salary for the Group Chief Executive and 125% for the Group Finance Director. In accordance with the Remuneration Policy, 20% of the bonus will be in the form of deferred shares.

LTIP awards were granted to both executive directors on 29 April 2019. These awards were based on absolute and relative TSR conditions, and EPS performance, measured for the three-year period ending 31 March 2022. The Company's TSR performance, being in the top 15% of the TSR peer group, and with an Absolute TSR growth of 104.5%, each over that three-year period, has resulted in full vesting of those elements of award. Total EPS growth for the period FY 2018/19 to FY 2021/22 was 12.9% CAGR, which resulted in full vesting of that element (see page 125 for further details). As a result, all of the 2019 LTIP award vested. The performance of the Acal BFi business was included for both the base year (in full) and for the final year (for the 11 months until disposal).

The values of these awards at the time of vesting are shown in the above table. Awards are subject to a two-year holding period.

### DIRECTORS' REMUNERATION POLICY

This part of the Directors' Remuneration Report sets out the remuneration policy which was approved at the annual general meeting on 29 July 2021 and which took formal effect from that date. It has been prepared in accordance with the Companies Act 2006 (the "Act") and the Large and Medium-sized Companies and Groups (Accounts and Reports) Regulations 2008 (as amended).

The Committee reviewed the Executive Directors' remuneration packages to ensure that they reflect the Company's own particular circumstances and are aligned with the Company's key strategic objectives, as set out in the Strategic Report, and with the long-term interests of its shareholders.

### Key objectives of our reward policy

The Remuneration Committee undertook a comprehensive review of the Executive Directors' remuneration arrangements and engaged with the Company's largest shareholders on the proposed changes. The primary aims of the policy are to deliver a remuneration package that is:

- Aligned with discoverIE's strategy at this stage of its development and supports the business's medium and long-term plans
- Consistent with practice internally and externally
- Competitive and fair compared against companies of our size and geographical complexity
- Focused on delivering long-term sustainable returns
- Compliant with shareholders' latest views on executive pay and the requirements of the 2018 UK Corporate Governance Code
- Able to attract and retain high calibre Executive Directors and senior managers in a challenging and competitive business environment
- Reduces complexity, delivering an appropriate balance between fixed and variable pay.

### When implementing the policy, the Committee:

- Takes account of pay and employment conditions elsewhere in the Group
- Ensures that incentive arrangements encourage responsible behaviour in all aspects of the Company's business, including financial, social, environmental and governance aspects; do not encourage excessive risk-taking; and are compatible with the Company's risk policies and procedures. The Committee has the discretion to take these factors into account when adjudicating bonus and LTIP outcomes.
- Enters into open dialogue and consults with key shareholders, when looking to make material changes to the remuneration policy.
- Considers market practice in terms of the structure and levels of executive remuneration.



Corporate Governance

## DIRECTORS' REMUNERATION REPORT

### Remuneration policy table

Element, purpose and link to strategy	Operation	Maximum opportunity	Performance targets
<p><b>Base salary</b> To attract and retain quality staff.</p>	<p>Salaries are normally reviewed annually with increases typically effective from 1 April.</p> <p>In determining Executive Directors' salaries, the Remuneration Committee takes into account:</p> <ul style="list-style-type: none"> <li>▪ Each Director's role, competence, experience and performance;</li> <li>▪ Average change in broader workforce pay; and</li> <li>▪ Total organisational salary budgets.</li> </ul> <p>Salaries are also benchmarked against companies of a comparable size and complexity and against companies which operate internationally, in similar sectors.</p>	<p>There is no prescribed maximum or maximum increase.</p> <p>However, any percentage increases will ordinarily be in line with those across the wider workforce.</p> <p>Salary increases may be higher in exceptional circumstances, such as the need to retain a critical executive, or an increase in the scope of the executive's role (including promotion to a more senior role) and/or in the size of the Group.</p>	<p>Although there are no formal performance conditions, any increase in base salary is only implemented after careful consideration of individual contribution and performance and having due regard to the factors set out in the 'Operation' column of this table.</p>
<p><b>Benefits</b> To help retain employees and remain competitive in the marketplace.</p>	<p>Directors, along with other senior UK executives, may receive certain benefits such as a car allowance, life assurance and critical illness cover, and family medical insurance.</p> <p>Any reasonable business-related expense (and any tax thereon) can be reimbursed if determined to be a taxable benefit.</p> <p>Executive Directors will be eligible to participate in any all-employee share plan operated by the Company, on the same terms as other eligible employees.</p> <p>For external and internal appointments or relocations, the Company may pay certain relocation and/or incidental expenses as appropriate.</p>	<p>There is no prescribed maximum as insurance cover can vary based on market rates.</p> <p>The maximum level of participation in all-employee share plans is subject to the limits imposed by the relevant tax authority from time to time.</p>	<p>Not applicable</p>



Element, purpose and link to strategy	Operation	Maximum opportunity	Performance targets
<p><b>Pension</b></p> <p>To facilitate long-term savings provisions.</p>	<p>The Company operates a defined contribution pension scheme.</p> <p>Executive Directors may take a cash allowance in lieu of pension contributions</p>	<p>The Group Chief Executive currently receives a Company contribution of 15% of base salary which will reduce to the contribution rate applying to the majority of the UK workforce rate in place at the time (8% of salary) from 1 January 2023.</p> <p>For the Group Finance Director, and any new Executive Directors appointed to the Board, the pension contribution will be in line with the majority of the UK workforce.</p>	<p>Not applicable</p>
<p><b>Annual bonus</b></p> <p>To reward the achievement of annual financial and strategic business targets.</p>	<p>Bonus is based on performance targets determined and reviewed by the Committee and are selected to be relevant for the year in question.</p> <p>Any payment is discretionary and the bonus payable is determined by the Committee after the financial year-end, based on performance against these targets.</p> <p>Financial objectives are updated to reflect acquisitions, disposals and currency movements during the year.</p> <p>20% of any bonus earned is deferred into discoverIE shares for a period of three years. Where applicable, dividends may accrue on deferred bonus shares.</p> <p>Malus and clawback provisions apply to cash and deferred elements of the bonus, applying in the event of material misstatement of the Company's financial results, an error of calculation or in the event of serious misconduct, material reputational damage or corporate failure.</p>	<p>The maximum bonus opportunity is 150% of salary for the Group Chief Executive and 125% of salary for other Executive Directors. Maximum bonus is payable for significant over-achievement of financial and non-financial bonus objectives.</p> <p>Typically, no more than 50% of the maximum bonus opportunity will be payable for achieving target performance.</p>	<p>The Committee sets performance measures and targets that are appropriately stretching each year, taking into account key strategic and financial priorities and ensuring there is an appropriate balance between incentivising Executive Directors to meet targets, while ensuring they do not drive unacceptable levels of risk or inappropriate behaviours.</p> <p>Financial measures may include (but are not limited to) underlying operating profit and Simplified Working Capital. Non-financial measures may include strategic measures directly linked to the Company's priorities.</p> <p>A graduated scale of targets is normally set for each measure, with no payout for performance below a threshold level of performance.</p> <p>The Committee has discretion to amend the pay-out should any formulaic outcome not reflect the Committee's assessment of overall business or individual performance.</p>

## DIRECTORS' REMUNERATION REPORT

Element, purpose and link to strategy	Operation	Maximum opportunity	Performance targets
<p><b>Long Term Incentive Plan</b></p> <p>To motivate Executives to deliver Shareholder value over the longer term.</p>	<p>Awards of conditional shares or nil-cost options are typically granted annually, which vest after three years dependent on the achievement of performance conditions and continued service.</p> <p>Vested awards are subject to a two-year post vesting holding period (net of tax, if applicable) in respect of their vested awards.</p> <p>Dividend equivalents may be paid in respect of awards to the extent they vest by reference to dividends declared during the award's vesting period and holding period.</p> <p>Malus and clawback may apply to vested and unvested LTIP awards in the event of material misstatement of the Company's financial results, an error of calculation or in the event of serious misconduct, material reputational damage or corporate failure.</p> <p>The Company's share schemes are funded through a combination of shares purchased in the market and newly issued shares, as appropriate. The Company monitors the number of shares issued under the schemes and their impact on dilution limits.</p>	<p>The maximum award in respect of any one financial year is an award over shares of market value at grant of 175% of salary.</p> <p>The Committee may increase the grant size of an LTIP award on grant (subject to the maximum award limit) if the award terms include that participants bear the cost of the Company's liability to employer's National Insurance arising on the settlement of their awards. The increased award size ensures that the participants are in a neutral position on an after-tax basis, assuming no change in tax rates.</p> <p>The Company is committed to remaining within the Investment Association's 10% dilution limit.</p>	<p>Performance metrics reflect the Group's strategic goals and milestones.</p> <p>The performance conditions may include, and are not limited to, relative or absolute TSR, earnings per share growth, return based measures, strategic measures and ESC-related objectives.</p> <p>The Committee retains discretion to set alternative weightings or performance measures for awards granted over the life of the policy.</p> <p>Threshold performance will normally result in no more than 25% of the award vesting.</p> <p>The Committee retains discretion to adjust vesting levels taking into account such factors as it considers relevant, including, but not limited to, the overall performance of the Company or the relevant Participant who holds the Award.</p>
<p><b>Shareholding guidelines</b></p> <p>To further align the interests of Executives with those of Shareholders.</p>	<p>Executive Directors are expected to accumulate the required shareholding requirement.</p> <p>Shares held which are no longer subject to performance conditions count towards the requirement (on a net of tax basis, if applicable).</p> <p>Executive Directors are required to retain at least 50% of their net of tax vested share awards until the in-employment shareholding guideline is met.</p>	<p>The current Executive Directors are required to build up and hold shareholdings to the value of 250% of salary.</p> <p>Any new Executive Directors appointed will be required to build up and hold shareholdings to the value of 200% of salary.</p> <p>Post cessation: Executive Directors are normally required to hold shares at a level equal to the lower of their shareholding at cessation and 200% of salary, for two years post-employment, from share awards granted after the date of approval by shareholders of this policy. This excludes any shares vesting from share plan awards made before such approval and shares purchased with own funds.</p>	<p>Not applicable.</p>

## Notes to the remuneration policy table

### Performance conditions and target setting

Each year, the Committee will determine the weightings, measures and targets as well as timing of grants and payments for the annual bonus and LTIP plans within the approved remuneration policy and relevant plan rules (or documents). The Committee considers a number of factors which assist in forming a view. These include, but are not limited to, the strategic priorities for the Company over the short to long term, shareholder feedback, the risk profile of the business and the macroeconomic climate.

The current Annual Bonus Scheme is measured against a balance of profitability, cash management and the delivery of key strategic areas of importance for the business. The profitability metric used for FY 2022/23 is adjusted underlying operating profit and the cash management metric is Simplified Working Capital.

The LTIP measures currently used are EPS growth targets and relative TSR. These measures were identified as those most relevant to driving sustainable bottom-line business performance, as well as providing value for shareholders.

Targets are set against the annual and long-term plans, taking into account analysts' forecasts, the Company's strategic plans, prior year performance, estimated vesting levels and the affordability of pay arrangements. Targets are set to provide an appropriate balance of risk and reward to ensure that, while being motivational for participants, maximum payments are only made for exceptional performance.

### Discretions and judgements

The Committee will operate the annual bonus plan and long-term incentive plan according to their respective rules and ancillary documents. Consistent with market practice, the Committee has discretion in a number of respects in relation to the operation of each plan. Discretions include:

- who participates in the plan;
- determining the timing of grants of awards and/or payments;
- determining the quantum of an award and/or payment;
- determining the extent of vesting;

- how to deal with a change of control or restructuring of the Group;
- whether an Executive Director or a senior manager is a good/bad leaver for incentive plan purposes and whether the proportion of awards that vest do so at the time of leaving or at the normal vesting date(s);
- how and whether an award may be adjusted in certain circumstances (e.g., for a rights issue, a corporate restructuring or for special dividends);
- what the weighting, measures and targets should be for the annual bonus plan and LTIP plans from year to year; and
- the Committee also retains the ability within the policy to vary and/or adjust targets and/or set different measures or weightings for the annual bonus plan and LTIP plans, if events occur that cause it to consider it appropriate to do so, and, in the case of the LTIP, any amended performance conditions are not materially less challenging than the original conditions would have been but for the events in question.

Any discretion exercised by the Committee in the adjustment of performance conditions will be fully explained to shareholders in the relevant report. If the discretion is material and upwards, the Committee will consult with major shareholders in advance.

All historical awards that have been granted before the date this policy came into effect and still remain outstanding (including those detailed on page 127 of the Annual Report on Remuneration) and remain eligible to vest based on their original award terms.

### Recruitment (and appointment) policy

The remuneration package for a new Executive Director would be set in accordance with the terms of the Company's approved remuneration policy in force at the time of appointment. Similar considerations may also apply where a Director is promoted to the Board from within the Group.



Corporate Governance

## DIRECTORS' REMUNERATION REPORT

Element	Recruitment policy
<b>Base salary</b>	<p>New Executive Director appointments will be offered a salary in line with the existing remuneration policy. The Committee will take into account a number of factors, including the current pay for other Executive Directors, external market forces, the expertise, skills and experience of the individual and current level of pay.</p> <p>Where the Committee has set the salary of a new appointment at a discount to the market level initially until proven, they may receive an uplift or a series of planned increases to bring the salary to the appropriate market position over time.</p>
<b>Benefits</b>	<p>Benefits provision would be in line with normal policy.</p> <p>The Committee may agree that the Company will meet appropriate relocation costs and/or incidental expenses as appropriate.</p>
<b>Pension</b>	<p>Pension contribution (or a cash allowance in lieu of contribution) provision will be no more than the general workforce contribution rate in place at the time.</p>
<b>Annual bonus</b>	<p>Eligible to take part in the annual bonus, with a maximum bonus opportunity not in excess of the limits set out in the policy.</p> <p>Depending on the timing of the appointment, the Committee may deem it appropriate to set different annual bonus performance conditions for the first performance year of appointment.</p>
<b>Long Term Incentive Plan</b>	<p>An LTIP award may be granted upon appointment but not in excess of the limits set out in the policy.</p> <p>An LTIP award may be made shortly following an appointment (assuming the Company is legally permitted to do so).</p>
<b>Compensation for forfeited remuneration</b>	<p>The approach in respect of compensation for forfeited remuneration in respect of a previous employer will be considered on a case-by-case basis taking into account all relevant factors, such as performance achieved or likely to be achieved, the proportion of the performance period remaining and the form of the award.</p> <p>The Committee retains the ability to make use of the relevant Listing Rule to facilitate the "buy-out". Any "buy-out" awards would have a fair value no higher than the remuneration forfeited.</p> <p>In the case of an internal appointment, any variable pay element awarded in respect of the prior role would be allowed to pay out according to its terms, adjusted as relevant to take into account the appointment.</p>
<b>Chairman and non-executive directors</b>	<p>For the appointment of a new Chairman or Non-Executive Director, the fee arrangement would be set in accordance with the approved Remuneration Policy.</p>



## Notice period and payment for loss of office

It is the Company's policy that Executive Directors should have service contracts incorporating a maximum notice period of one year. However, it may be necessary occasionally to offer longer initial notice periods to new Directors. Under the terms of their service contracts, any termination payments are not predetermined but are determined in accordance with the Director's contractual rights, taking account of the circumstances and the Director's duty to mitigate loss. The Company's objective is to manage its exposure to the risk of a potential termination payment.

Non-Executive Directors have letters of appointment for a term of three years, subject to re-appointment by shareholders at each annual general meeting. In line with the UK Corporate Governance Code, they are generally renewed for no more than nine years in aggregate. Non-Executive Directors are not eligible for payment on termination, other than payment to the end of their notice periods.

Name	Role	Date of original appointment	Expiry of current term
Malcolm Diamond	Chairman	1 November 2015	31 October 2024
Nick Jefferies	Group Chief Executive	5 January 2009	12 months by either Director or Company
Simon Gibbins	Group Finance Director	10 June 2010	12 months by either Director or Company
Tracey Graham	Non-Executive Director	1 November 2015	31 October 2024
Rosalind Kainyah	Non-Executive Director	1 January 2022	31 December 2024
Bruce Thompson	Non-Executive Director	26 February 2018	25 February 2024
Clive Watson	Non-Executive Director	2 September 2019	1 September 2022

Other than their service contracts, no contract of significance, to which any member of the discoverIE Group is a party and in which a Director is or was materially interested, subsisted at the end of, or during, the year.

## Termination payments for Executive Directors

On termination, the Company will normally make a payment in lieu of notice ("PILON") which is equal to the aggregate of the base salary and cash equivalent of other benefits for the applicable notice period.

The Company may pay the PILON either as a lump sum or in equal monthly instalments, from the date on which the employment terminates until the end of the relevant period. If alternative employment is commenced, for each month that instalments of the PILON remain payable, the monthly amount paid may be reduced by the amount received from such alternative employment.

If identified as a 'good leaver' for the purposes of the bonus plan, the bonus payout will be pro-rated based on the Committee's reasonable assessment of the achievement of the performance measures in respect of the relevant financial year.

The treatment of LTIP awards on termination will be in accordance with the plan rules and, where appropriate, at the discretion of the Committee.

If identified as a 'good leaver' under the LTIPs and share option schemes' rules, (including those good leavers identified as being at the discretion of the Committee), outstanding awards may be exercised, normally pro rata for service up until the date of leaving and subject to the outcome of the performance conditions, either on the normal release or on such earlier date as the Committee may determine.

The Committee may also agree to make payments in respect of statutory employment claims, reasonable legal fees, outplacement and accrued holiday or sick leave.

## Change of control or restructuring

On a change of control, all LTIP awards will be released, subject to performance requirements and will ordinarily be prorated according to completion of the vesting period. In line with market practice and the Plan rules, the final treatment of any awards is subject to the discretion of the Committee.

There are no enhanced bonus provisions on a change of control.

## DIRECTORS' REMUNERATION REPORT

### Comparison with remuneration policy for other employees

The Company's approach to salary reviews is consistent throughout the Company with consideration given to responsibility, experience, performance, salary levels in comparable organisations and the Company's ability to pay.

Differing bonus arrangements (which are normally discretionary) operate elsewhere in the organisation and, subject to role, employees are entitled to benefits such as healthcare, car allowance (or Company-funded vehicle), life assurance and critical illness cover.

### Fees for Non-Executive Directors

Fees for the Non-Executive Directors are determined on behalf of the Board by the Non-Executive Directors' Remuneration Committee. When determining fees, due regard is given to fees paid to Non-Executive Directors in other similarly-sized UK quoted companies, the time commitment and the responsibilities of the roles. Non-Executive Directors

cannot participate in any of the Company's share incentive schemes and no Director is involved in any decision regarding their own remuneration. As disclosed on page 122 of this Annual Report and Accounts, additional fees, over and above the base fee payable to the Non-Executive Directors, are payable for chairing the Audit & Risk, Remuneration and Sustainability Committees and for acting as Senior Independent Director.

Fees are normally reviewed annually to ensure that they reflect an individual's time commitment and responsibilities.

### External appointments

The Executive Directors are entitled to accept one appointment outside the Group, provided that the Chairman's permission is obtained in advance of accepting an appointment and specific approval is given by the Board. Neither of the Executive Directors who served during the year held any non-executive appointments outside the Group.

### Illustrations of the application of the Executive Directors' remuneration policy

The bar charts below illustrate some possible outcomes of the application of the policy (approved by shareholders at the annual general meeting on 29 July 2021) for the year ending 31 March 2023.

#### Group Chief Executive

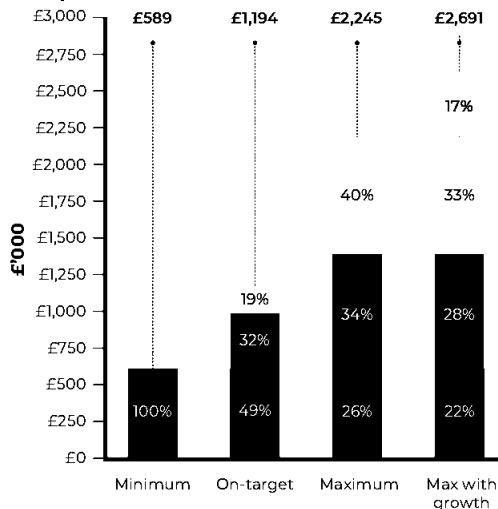

#### Group Finance Director

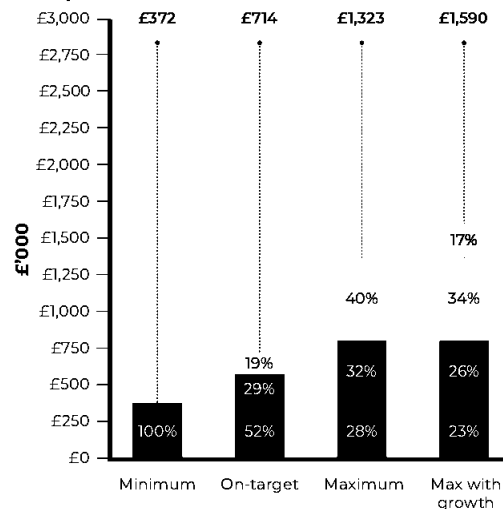

● Fixed ● Annual Bonus ● Long-term incentive ● Share price growth

- 1 Minimum in the bar charts above is fixed remuneration only (i.e., salary, pension and benefits as disclosed in the single figure table).
- 2 Target assumes that 25% of the LTIP award vests (based on an award with a face value of 175% and 160% of salary for the Group Chief Executive and Group Finance Director respectively) and bonuses have been earned at the target levels (75% of salary for the Group Chief Executive and 62.5% of salary for the Group Finance Director).
- 3 Maximum assumes that the Long Term Incentive Plan ("LTIP") award vests in full (based on an award with a face value of 175% and 160% of salary for the Group Chief Executive and Group Finance Director) and the maximum bonus (150% and 125% of salary for the Group Chief Executive and Group Finance Director) have been earned.
- 4 Maximum plus share price growth – this is based on the maximum scenario set out above but with a 50% share price increase applied to the value of LTIP awards.



Projected values do not take into account dividend accrual or additional awards granted as a result of any agreement by an Executive Director to incur the Company's liability to employers' National Insurance.

### Consideration of employment conditions elsewhere in the Group

The remuneration policy, which has been implemented for the current Executive Directors, is more weighted towards performance-related pay than for other employees. The reason for this is to establish a clear link between remuneration received by the Executive Directors and the creation of shareholder value.

As mentioned on page 113 of this Annual Report and Accounts, when setting the policy the Committee takes account of pay and employment conditions elsewhere in the Group, but has not used any remuneration comparison measures between the Executive Directors and other employees.

### Employee Engagement

As outlined on pages 75 and 90, there are a range of employee engagement initiatives in place across the Group and, as part of this employee engagement, the Company explains how its strategy links to remuneration and provides the opportunity for employees to ask questions and

provide feedback on that strategy. In addition to those existing mechanisms, during the year the Group consulted specifically on UK pensions provision. That consultation reflected on both the need to improve pensions for our staff, as well as wider inflationary pressures (both in the UK and globally). The outcome of that review was an increase in pension provision across the UK workforce. Additionally, management was consulted globally in preparation for the publication of the Group's Human Rights Policy (available at [www.discoverieplc.com](http://www.discoverieplc.com)), in which the Group states that it is committed to paying wages at rates that are meaningfully ahead of minimum statutory rates.

### Consideration of Shareholder views

The Committee's policy is to receive updates on the views of shareholders and their representative bodies on best practice, and take these into account. It seeks the views of key shareholders on matters of remuneration in which it believes they may be interested. This includes a comprehensive shareholder consultation exercise undertaken with the Group's largest shareholders in determining the changes applied to this Directors' Remuneration Policy.





Corporate Governance

## DIRECTORS' REMUNERATION REPORT

### ANNUAL REPORT ON REMUNERATION

Information subject to audit

The table below shows the total remuneration earned by executive directors for the year ended 31 March 2022 and the prior year.

#### Single total figure of remuneration for each Executive Director (audited)

		Salary £000	Benefits <sup>1</sup> £000	Pension <sup>2</sup> £000	Total Fixed Remuneration	Bonus <sup>3</sup> £000	LTIP <sup>4</sup> £000	Total Variable Remuneration	Total £000
<b>Nick Jefferies</b>	<b>FY22</b>	<b>490</b>	<b>11</b>	<b>74</b>	<b>575</b>	<b>735</b>	<b>1,270</b>	<b>2,005</b>	<b>2,580</b>
	FY21	443	11	62	516	333	868	1,201	1,717
<b>Simon Gibbins</b>	<b>FY22</b>	<b>326</b>	<b>12</b>	<b>21</b>	<b>359</b>	<b>407</b>	<b>703</b>	<b>1,110</b>	<b>1,469</b>
	FY21	295	12	18	324	178	442	620	944

<sup>1</sup> Taxable benefits comprise car allowance (£9,000 each) and family medical insurance. The total value of benefits for 2022 were £11,388 and £11,856 for Nick Jefferies and Simon Gibbins respectively.

<sup>2</sup> Pension in the year under review for Nick Jefferies and Simon Gibbins was paid as cash in lieu of pension and was equal to 15% and 6.5% of salary respectively.

<sup>3</sup> For performance in the year under review, a bonus of 150% and 125% of salary was earned by Nick Jefferies and Simon Gibbins, respectively. Further details of performance against the targets can be found on pages 123 to 124. In accordance with the Remuneration Policy, 20% of these bonuses will be in the form of deferred shares. The values in the above table include the cash and deferred elements in line with the reporting requirements. No discretion was applied by the Remuneration Committee.

<sup>4</sup> The LTIP awarded granted to Nick Jefferies and Simon Gibbins on 30 April 2019 vested in full on 30 April 2022. Further details of performance against the targets can be found on page 125. Of the FY22 LTIP values shown in the table above (which are based on the share price at 30 April 2022 of £7.64), £570,189 of Nick Jefferies and £315,581 of Simon Gibbins, is attributed to share price growth over the vesting period. No discretion was applied by the Remuneration Committee. Dividends will accrue on these awards between the date of vesting and exercise.

#### Single total figure of remuneration for Non-Executive Directors (audited)

	Basic fee <sup>2</sup>		Committee Chair fees		SID fee		Total	
	FY22 £	FY21 £	FY22 £	FY21 £	FY22 £	FY21 £	FY22 £	FY21 £
Malcolm Diamond	<b>147,000</b>	133,000	–	–	–	–	<b>147,000</b>	133,000
Tracey Graham	<b>48,300</b>	43,700	<b>8,400</b>	7,600	–	–	<b>56,700</b>	51,300
Rosalind Kainyah <sup>1</sup>	<b>12,075</b>	–	–	–	–	–	<b>12,075</b>	–
Bruce Thompson	<b>48,300</b>	43,700	–	–	<b>8,400</b>	7,600	<b>56,700</b>	51,300
Clive Watson	<b>48,300</b>	43,700	<b>8,400</b>	7,600	–	–	<b>56,700</b>	51,300

<sup>1</sup> Joined the Board on 1 January 2022

<sup>2</sup> Each of the Executive and Non-Executive Directors agreed to a 20% reduction in their base fees for the three-month period from June 2020 to August 2020.

#### Incentive outcomes for Executive Directors for the year ended 31 March 2022

##### Annual bonus in respect of performance for the year

The maximum bonus opportunity for the year under review was 150% and 125% of salary for the Group Chief Executive and the Group Finance Director respectively. Annual bonuses for the year under review were based on a sliding scale of operating profit targets (60%), simplified working capital (24%) and the achievement of non-financial objectives (16%).

Based on the strong performance during the year, both the profit performance and Simplified Working Capital were above the maximum target and non-financial objectives were determined to have been met in full. This performance has resulted in bonuses of 100% of maximum.



Further details, including the targets set and performance against each of the metrics, are provided in the table below:

	Weighting	Threshold <sup>1</sup>	Target (50% payable)	Maximum (100% payable)	Actual	Bonus earned (% of maximum)
Group underlying operating profit (£m) <sup>2</sup>	60%	£29.46m	£33.7m	£37.9m	£41.4m	100%
SWC <sup>2 3</sup>	24%	23.1%	22.0%	20.9%	20.7%	100%
Individual objectives <sup>2</sup>	16%				see below	100%
Outcome (% of max)						100%

<sup>1</sup> Threshold payout under the underlying operating profit target is 10% of salary for both directors and under the Simplified Working Capital measure is nil.

<sup>2</sup> Audited information

<sup>3</sup> Simplified Working Capital (SWC) is calculated based on the average of trade payables and receivables and inventories across the financial year, as a percentage of total Group revenue (for continuing operations)

Each Executive Director was given a number of individual non-financial objectives, tailored to their role and to business requirements in the year under review. Nick Jefferies and Simon Gibbins each achieved their non-financial objectives in full.

### Nick Jefferies

Objective	Performance	Assessment
<b>Develop growth drivers for achieving 5-year plan (organic growth and acquisitions)</b>	Record levels of organic growth and design wins Three key acquisitions	Achieved
<b>Develop ESG initiatives, implementation and reporting (including target markets, carbon initiatives, reporting analytics, annual report development for sustainability and social initiatives)</b>	Target markets aligned to UN SDGs Carbon reduction plan making good progress Energy audit and ISO accreditation plans in place Initial TCFD reporting included in the Annual Report and publication of updated ESG-aligned policies Increased diversity at Head Office and in senior Group management	Achieved
<b>Increase sales in target markets in line with KSI objectives</b>	Target market sales increase to 76% of Group revenue	Achieved
<b>Develop international investor base</b>	Non-UK investors increased by 5%	Achieved
<b>Develop organisation to support growth</b>	New Investor Relations and ESG executive appointed	Achieved



Corporate Governance

## DIRECTORS' REMUNERATION REPORT

### Simon Gibbins

Objective	Performance	Assessment
Ensure adequacy of group funding for growth	Extension of the Group's revolving credit facility secured (£240m, plus £80m accordion, to June 2027)	Achieved
Develop ESG initiatives, implementation and reporting	Increased resource & investment in carbon reduction initiatives  Updated Policies, including Supplier Code of Conduct, Conflict Minerals Policy, Human Rights Policy, revised Anti-Bribery & Corruption Programme, extended schedule of supplier audits  New internal controls, including updated Group Accounting Manual, detailed Senior Accounting Officer review	Achieved
Develop international investor and analyst base	Non-UK investors increased by 5%	Achieved
Further develop internal audit function and resource	Additional resource recruited into Risk & Internal Audit team and tax teams	Achieved
Manage increased tax scrutiny as a 'large' business	Successful subsidiary risk and anti-bribery and corruption reviews completed  Planning and initial activities undertaken in preparation for the impact of the UK's audit and governance reform proposals as set out in the BEIS consultation published on 18 March 2021 ('UK Sox')	Achieved

The Committee assessed these achievements against the pre-set personal objectives and in the context of overall business performance and decided to award Nick Jefferies and Simon Gibbins a full payout for this element of their respective bonuses. This means that, in total for the year under review, Nick Jefferies earned a bonus of 150% of his salary and Simon Gibbins earned a bonus of 125% of his salary. In accordance with the Remuneration Policy, 20% of all bonuses are deferred into shares, as follows:

	Bonus outcome (% of maximum)	Bonus opportunity (% of salary)	Bonus outcome (£)	Cash element (£) 80%	Deferred share element (£) 20%
Nick Jefferies	100%	150%	£735,138	£588,110	£147,028
Simon Gibbins	100%	125%	£406,875	£325,500	£81,375

The deferred shares will vest three years after grant. Other than the malus and clawback terms referred to on page 115, there are no conditions, whether performance or non-performance related, attached to these shares.

## 2019 LTIP vesting (audited)

LTIP Awards were granted on 30 April 2019 to Nick Jefferies and Simon Gibbins with vesting dependent on relative TSR performance against a comparator group made up of constituents of the FTSE Small Cap Index (1/3), absolute TSR in excess of CPI (1/3) from 31 March 2019 to 31 March 2022 and the growth in EPS between the year ended 31 March 2019 and the year ended 31 March 2022 (1/3). The specific targets were as follows:

### Relative TSR ranking against the FTSE Small Cap (1/3 weighting)

Relative TSR ranking against peers	% of award vesting	Actual performance
Upper quartile (or above)	100%	discoverIE's TSR over the period was 104.5% which ranked the company in the upper quartile of the peer group.
Between median and upper quartile	Straight-line vesting between 25% and 100%	
Below median performance	0%	

### Absolute TSR performance (1/3 weighting)

Absolute TSR performance	% of award vesting	Actual performance
Equal to or above CPI +30ppts	100%	discoverIE's TSR over the period was 104.5% which was in excess of CPI+30ppts.
Between CPI +10ppts and CPI +30ppts	Straight-line vesting between 25% and 100%	
Below CPI +10ppts	0%	100% vesting

### EPS Performance (1/3 weighting)

EPS growth from FY18 to FY21	% of award vesting	Actual performance
Equal to or above 12ppts pa	100%	12.9ppts growth over the three-year period
Between 5ppts pa and 12ppts pa	Straight-line vesting between 25% and 100%	
Below 5ppts pa	0%	100% vesting

The disposal of Acal BFi was announced on 9 November 2021 and completed on 3 March 2022, shortly before the year end. Given that Acal BFi was part of the Group for the majority of FY 2021/22, the EPS condition was measured by including Acal BFi for the whole of the base year (as it was within the Group for the whole of that year) and for 11 months of the final year (i.e., up to the date of disposal). The growth over the period is 12.9%p.a., which is higher than the maximum hurdle. Therefore, this element of the award also vested in full. No discretion was applied. This element of the award would also have vested in full if Acal BFi had been fully removed from the calculations.

The three performance measures were met in full and therefore all of the 2019 LTIP award vested. The vested awards are subject to a two-year holding period, during which period dividends will accrue on the vested awards. No dividends accrued between the date of grant and vesting.



Corporate Governance

## DIRECTORS' REMUNERATION REPORT

### Share awards made during the year (audited)

The following LTIP awards were granted on 29 July 2021:

Director	Face value as % of salary	Face value <sup>1</sup>	Number of shares	Threshold vesting (% of face value)	Maximum vesting (% of face value)	End of performance period
Nick Jefferies	150%	£735,137	74,482	25%	100%	31 March 2024
Simon Gibbins	135%	£439,425	44,521			31 March 2024

<sup>1</sup> The face value of the awards is based on a share price of £9.87, being the three-day average share price directly prior to the grant of the award.

In addition to the grants set out above, 12,413 awards were granted to Nick Jefferies and 7,441 awards were granted to Simon Gibbins (with a face value of £122,516 and £73,443 respectively, based on a share price of £9.87), in return for them bearing the Company's liability to employer's National Insurance arising on the exercise of such grants. The additional awards ensure they are in a neutral position on an after-tax basis, assuming unchanged tax rates. The awards were granted on the same date and under the same conditions as those set out in the table above.

Vesting of these awards is subject to the following performance conditions:

### Relative TSR ranking against the FTSE Small Cap excluding Investment Trusts (50% weighting)

Relative TSR ranking against peers	% of award vesting
Upper quartile (or above)	100%
Between median and upper quartile	Straight-line vesting between 25% and 100%
Below median performance	0%

### EPS Growth (50% weighting)

EPS Growth	% of award vesting
Equal to or above 12ppts per annum	100%
Between 5ppts and 12ppts per annum	Straight-line vesting between 25% and 100%
Below 5ppts per annum	0%

Performance is measured over three years from 1 April 2021 to 31 March 2024 using, for the TSR measure, share prices averaged over the previous month, prior to the start and end of the performance period. In the case of EPS Growth, performance will be measured from FY 2020/21 to FY 2023/24. Vested shares will be subject to an additional two-year holding period.

Deferred bonus share awards: As part of the terms of the bonus relating to FY2020/21, 20% of Nick Jefferies' annual bonus was deferred into shares. On 25 June 2021, 3,703 shares were acquired at a price of £9.44 per share (representing 20% of the FY 2020/21 bonus net of tax).

### Pension arrangements (audited)

The Company does not operate a defined benefit pension scheme for Executive Directors. Pension contributions/cash allowances for the Executive Directors are set out in the policy table on page 115 of this Report.

## Directors' interests under the Long-Term Incentive Plans

Movements in the Executive Directors' holdings of nil-cost options under the LTIPs during the year are shown below. The performance criteria for the LTIPs are set out on page 126.

	Number held at 31.03.22	Movements during the year				Number held at 31.03.21	Vested but not exercised	Share value at 31.03.22 £	When exercisable
		Granted	Vested	Exercised	Lapsed				
Nick Jefferies	0 <sup>1</sup>	–	–	245,192	–	245,192	0	0	N/A
	0 <sup>2</sup>	–	–	223,567	–	223,567	0	0	N/A
	242,788(v) <sup>3</sup>	–	–	–	–	242,788	242,788	1,933,169	Mar 2022 to Mar 2027
	123,998(v) <sup>4</sup>	–	–	–	–	123,998	123,998	977,104	Mar 2023 to Mar 2028
	166,236(v) <sup>5</sup>	–	166,236	–	–	166,236	166,236	1,309,940	Apr 2024 to Apr 2029
	127,039(nv) <sup>6</sup>	–	–	–	–	127,039	–	1,001,067	Jul 2025 to Jun 2030
	74,482 (nv) <sup>7</sup>	74,482	–	–	–	–	–	586,918	Jul 2026 to Jul 2031
Simon Gibbins	0 <sup>8</sup>	–	–	120,192	–	120,192	0	0	N/A
	0 <sup>9</sup>	–	–	98,437	–	98,437	0	0	N/A
	106,900(v) <sup>10</sup>	–	–	–	–	106,900	106,900	842,372	Mar 2022 to Mar 2027
	63,190(v) <sup>11 12</sup>	–	–	–	–	63,190	63,190	497,937	Mar 2023 to Mar 2028
	92,006(v) <sup>13 14</sup>	–	92,006	–	–	92,006	92,006	725,007	Apr 2024 to Apr 2029
	62,500(nv) <sup>15</sup>	–	–	–	–	62,500	–	492,500	Jul 2025 to Jun 2030
	44,521 (nv) <sup>16</sup>	44,521	–	–	–	–	–	350,825	Jul 2026 to Jul 2031

(v)= vested; (nv) = non-vested

- The award, in the form of a nil-cost option over 245,192 shares in the Company was made to Nick Jefferies on 31 March 2015. The performance conditions attached to the award resulted in 100% vesting on 31 March 2018. These options were exercised on 7 December 2021.
- The award, in the form of a nil-cost option over 223,567 shares in the Company was made to Nick Jefferies on 31 March 2016. The performance conditions attached to the award resulted in 100% vesting on 31 March 2019. These options were exercised on 28 March 2022.
- The award, in the form of a nil-cost option over 242,788 shares in the Company was made to Nick Jefferies on 31 March 2017. The performance conditions attached to the award resulted in 100% vesting on 31 March 2020.
- The award, in the form of a nil-cost option over 163,371 shares in the Company was made to Nick Jefferies on 29 March 2018. The performance conditions attached to the award resulted in 75.9% vesting (123,998 options) on 29 March 2021.
- The award, in the form of a nil-cost option over 166,236 shares in the Company was made to Nick Jefferies on 30 April 2019. The performance conditions attached to the award resulted in 100% vesting on 30 April 2022.
- An additional award of 13,995 nil-cost options was made on 30 June 2020 such that Nick Jefferies is in a net neutral position after tax, assuming unchanged tax rates, as a result of his agreement to take on a proportion of the Company's liability to employer's National Insurance on the June 2020 award. This is in addition to the 127,039 shares set out above and is subject to the same vesting and exercise conditions.
- An additional award of 12,413 nil-cost options was made on 29 July 2021 such that Nick Jefferies is in a net neutral position after tax, assuming unchanged tax rates, as a result of his agreement to take on a proportion of the Company's liability to employer's National Insurance on the July 2021 award. This is in addition to the 74,482 shares set out above and is subject to the same vesting and exercise conditions.
- The award, in the form of a nil-cost option over 120,192 shares in the Company was made to Simon Gibbins on 31 March 2015. The performance conditions attached to the award resulted in 100% vesting on 31 March 2020. These options were exercised on 7 December 2021.
- The award, in the form of a nil-cost option over 98,437 shares in the Company was made to Simon Gibbins on 31 March 2016. The performance conditions attached to the award resulted in 100% vesting on 31 March 2020. These options were exercised on 25 March 2022.
- The award, in the form of a nil-cost option over 106,900 shares in the Company was made to Simon Gibbins on 31 March 2017. The performance conditions attached to the award resulted in 100% vesting on 31 March 2020.
- The award, in the form of a nil-cost option over 83,255 shares in the Company was made to Simon Gibbins on 29 March 2018. The performance conditions attached to the award resulted in 75.9% vesting (63,190 options) on 29 March 2021.
- An additional award of 13,916 nil-cost options was made on 29 March 2018 such that Simon Gibbins is in a net neutral position after tax, assuming unchanged tax rates, as a result of his agreement to take on the Company's liability to employer's National Insurance on the March 2018 award. 75.9% of the 2018 award vested on 29 March 2021; meaning 63,190 options from the "base award" vested and 20,065 options from the "base award" lapsed; and 10,562 options from the NI element vested and 3,353 options from the NI element lapsed.
- The award, in the form of a nil-cost option over 92,006 shares in the Company was made to Simon Gibbins on 30 April 2019. The performance conditions attached to the award resulted in 100% vesting on 30 April 2022.
- An additional award of 15,379 nil-cost options was made on 30 April 2019 such that Simon Gibbins is in a net neutral position after tax, assuming unchanged tax rates, as a result of his agreement to take on the Company's liability to employer's National Insurance on the April 2019 award. This is in addition to the 92,006 shares set out above.
- An additional award of 10,446 nil-cost options was made on 30 June 2020 such that Simon Gibbins is in a net neutral position after tax, assuming unchanged tax rates, as a result of his agreement to take on the Company's liability to employer's National Insurance on the June 2020 award. This is in addition to the 62,500 shares set out above and is subject to the same vesting and exercise conditions.
- An additional award of 7,441 nil-cost options was made on 29 July 2021 such that Simon Gibbins is in a net neutral position after tax, assuming unchanged tax rates, as a result of his agreement to take on the Company's liability to employer's National Insurance on the July 2021 award. This is in addition to the 44,521 shares set out above and is subject to the same vesting and exercise conditions.



Corporate Governance

## DIRECTORS' REMUNERATION REPORT

### Directors' interests (audited)

The interests of the Directors, who held office as at 31 March 2022 (including family interests) in ordinary shares (fully paid, 5p) of the Company, were as follows:

	Shares held at 31 March 2022					
	Unencumbered shares	Nil cost options vested but not exercised and outside of holding period	Nil cost options vested but subject to additional holding period	Nil cost options subject to performance conditions	Unencumbered shares held at 31 March 2021	Value of current shareholding (% of salary)
Nick Jefferies	1,241,830 <sup>1</sup>	242,788	290,234	201,521	981,400	2,744%
Simon Gibbins	388,264	106,900	155,196	107,021	267,489	1,536%
Tracey Graham	10,330	–	–	–	9,358	
Malcolm Diamond	30,982	–	–	–	27,316	
Bruce Thompson	45,000	–	–	–	25,000	
Clive Watson	19,125	–	–	–	12,500	
Rosalind Kainyah	656	–	–	–		

<sup>1</sup> Nick Jefferies holds 1,222,477 shares outright. In line with the Remuneration Policy, 20% of the FY 2018/19 to FY 2020/21 bonuses were deferred into shares. The figure of 1,241,830 includes the shares bought with those deferred bonuses, which were 9,694, 5,956 and 3,703 shares respectively.

<sup>2</sup> Options subject to the additional holding period are not capable of exercise. No further performance conditions apply.

The interests of all Directors at 1 June 2022 are unchanged from those at 31 March 2022. The values of current shareholdings for Nick Jefferies and Simon Gibbins have been valued using the share price as at 31 March 2022 of 788p and include all options that have vested and are based on salaries as at 1 June 2022.

Executive Directors are required to build up/maintain a shareholding of at least 200% of salary, including LTIP shares where performance conditions no longer apply, within five years. Both of the Executive Directors have met the current shareholding requirements. In accordance with the remuneration policy, Executive Directors are required to build up/maintain a shareholding of at least 250% of salary within seven years. Both of the Executive Directors meet the shareholding requirements. The figures for shares/nil cost options subject to performance conditions exclude any additional awards to Executive Directors in respect of employer's National Insurance.

### Dilution

The Company's share schemes are funded through a combination of shares purchased in the market and newly issued shares, as appropriate. The Company monitors the number of shares issued under the schemes and their impact on dilution limits.

As at 31 March 2022, approximately 4.90m shares (5.1% in the last ten years) have been, or may be, issued to settle awards made in the last ten years in connection with all share schemes and executive share schemes, respectively. The Company is committed to remaining within The Investment Association's 10% in 10 years dilution limit.

### Payments for loss of office (audited)

There were no payments for loss of office during the year.

### Payments to past Executive Directors (audited)

There were no payments to past Executive Directors during the year.

This represents the end of the audited section of the Report.

### Pay for performance

The graph below shows Total Shareholder Return (TSR) in terms of change in value (with dividends deemed to be reinvested gross on the ex-dividend date) of an initial investment of £100 on 1 April 2012 between that date and 31 March 2022 in a holding of the Company's shares, compared with the corresponding TSR in a hypothetical holding of £100 invested in the FTSE 250 Index. This index has been updated from the FTSE SmallCap index shown in previous reports to reflect the Company's entry into the FTSE 250. The index has been chosen because it is considered to be a reasonable comparator in terms of the Company's size and its share liquidity. The accompanying table details the Group Chief Executive's single figure of remuneration and actual variable pay outcomes over the same period.

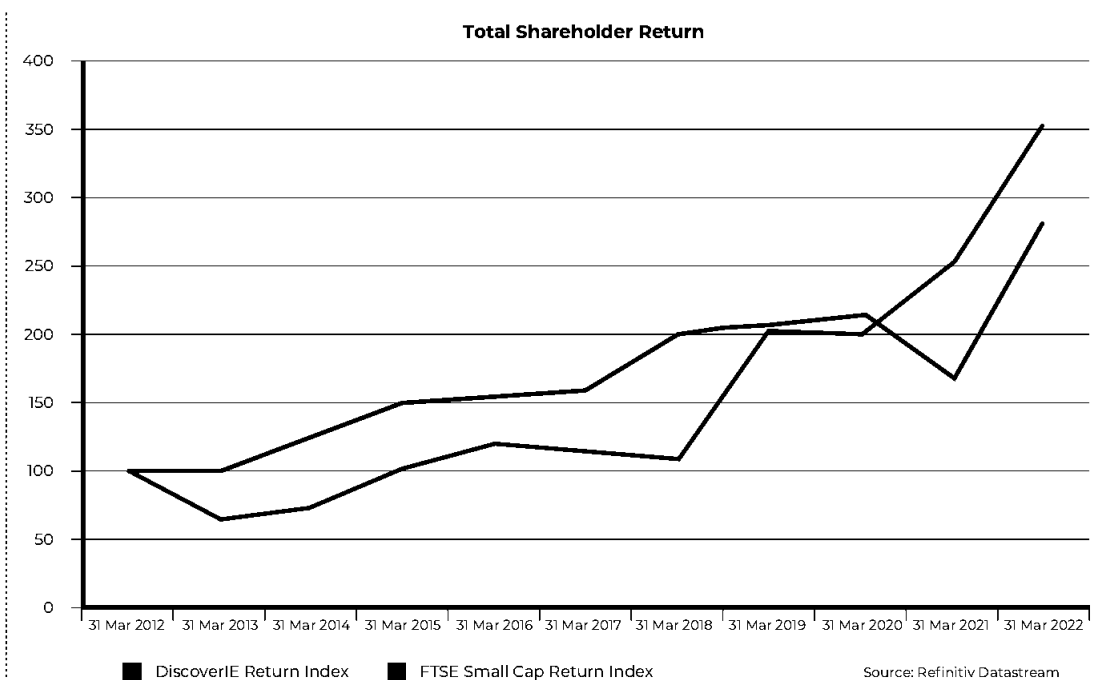

### Group Chief Executive single figure of total remuneration history

Note: The Company's share price was adjusted following the rights issue in June 2014.

Nick Jefferies was Group Chief Executive throughout the period shown in the table below.

	2013	2014	2015	2016	2017	2018	2019	2020	2021	2022
Single figure of total remuneration (£'000)	999	572	1,246	1,321	665	1,803	1,796	2,093	1,717	<b>2,580</b>
Salary (£'000)	320	320	330	425	429	438	453	467	443	<b>490</b>
Bonus outcome (% of maximum)	20	55	59	60	43.5	63.7	69.2	62.0	60.1	<b>100</b>
LTIP outcome (% of maximum)	88	9	100	100	–	100	100	100	75.9	<b>100</b>
Turnover (£m)	177	212	271	288	338	387.9	438.9	466.4	454.3	<b>379.2</b>
Underlying operating profit (£m)	5	7	13	16	20	24.5	30.6	37.1	35.2	<b>41.4<sup>1</sup></b>

<sup>1</sup> Continuing operations



Corporate Governance

## DIRECTORS' REMUNERATION REPORT

### Group Chief Executive remuneration

#### Annual Percentage Change in Remuneration of Directors and employees

As required by the 2019 regulations, the table below shows a comparison of the annual change of each individual Director's pay to the annual change in average UK employee pay. discover!E Group plc has no employees itself and therefore the Committee has selected this comparator group on the basis that the Executive Directors are UK-based. Average employee pay is based on a Full Time Equivalent (FTE) calculation.

	% change from 2020 to 2021			% change from 2021 to 2022		
	Salary or fees	Benefits	Bonus	Salary or fees	Benefits	Bonus
<b>Employees</b>	5%	0%	44%	<b>5%</b>	<b>0%</b>	<b>153%</b>
<b>Executive Directors</b>						
Nick Jefferies	-5%	-3%	-8%	<b>11%</b> <sup>1</sup>	<b>2%</b>	<b>121%</b>
Simon Gibbins	-5%	-3%	-8%	<b>11%</b> <sup>1</sup>	<b>2%</b>	<b>129%</b>
<b>Non-Executive Directors</b>						
Malcolm Diamond	-5%	–	–	<b>11%</b> <sup>1</sup>	–	–
Tracey Graham	-5%	–	–	<b>11%</b> <sup>1</sup>	–	–
Rosalind Kainyah	n/a <sup>2</sup>	–	–	<b>n/a</b> <sup>2</sup>	–	–
Bruce Thompson	-5%	–	–	<b>11%</b> <sup>1</sup>	–	–
Clive Watson	-5%	–	–	<b>11%</b> <sup>1</sup>	–	–

<sup>1</sup> Salaries and fees for the year ended 31 March 2021 were voluntarily reduced by all Directors by 20% for three months in light of the pandemic, as explained in last year's Report. Without that reduction, the underlying increase in salary and fees was 5%.

<sup>2</sup> Joined the Board in January 2022.

#### CEO pay ratio

The table below sets out the pay ratios for the Group Chief Executive in relation to the equivalent pay for the lower quartile, median and upper quartile employees (calculated on a full-time basis). The principal reason for the changes between 2020, 2021 and 2022 are the changes in the overall remuneration of the Group Chief Executive, with a voluntary reduction in salary and bonuses in 2021 and a full payout this year.

Year	Method	25th percentile pay ratio	Median pay ratio	75th percentile pay ratio
<b>2022</b>	Option B	117:1	68:1	44:1
<b>2021</b>	Option B	63:1	47:1	25:1
<b>2020</b>	Option B	83:1	57:1	40:1

<sup>1</sup> The Company determined the remuneration figures for the employee at each quartile with reference to a date of 31/3/22.

<sup>2</sup> The Group used calculation method B as the Gender Pay Gap data is already collated for UK employees and was therefore readily available.

<sup>3</sup> Following a review, the Committee was satisfied that the three individuals reported on are representative of the lower quartile, median and upper quartile employees. No adjustments or estimates were used.

Set out in the table below is the total pay and benefits as well as the salary component of remuneration for the employees identified as being at the relevant percentiles.

£	25th percentile	Median	75th percentile
<b>Salary</b>	20,063	30,104	50,141
<b>Total pay and benefits</b>	22,109	37,977	58,426

#### Importance of the spend on pay

The table below shows the importance of the spend on pay for all employees across the globe compared with the returns distributed to shareholders, during the year under review and the prior financial year. The information is based on like-for-like constant currency and includes annualised prior year acquisitions.

£	2022 £m	2021 £m	change %
Remuneration paid to or receivable by all employees	84.1	70.0	+20%
Distributions to shareholders by way of dividends (net of share issues)	9.4	2.8	+236%



## Statement of implementation of the remuneration policy in the financial year ending 31 March 2023

The table below sets out a summary of how the remuneration policy will apply during 2022/23.

Remuneration element	Remuneration for year ending 31 March 2023
<b>Base salary</b>	<ul style="list-style-type: none"> <li>Salaries for FY 2022/23 are:                             <ul style="list-style-type: none"> <li>£509,695 for the Group Chief Executive (4% increase).</li> <li>£333,638 for the Group Finance Director (2.5% increase).</li> </ul> </li> </ul> <p>The UK workforce increase was c.4-5% and higher increases of up to 15% were made in certain overseas territories the Group operates in.</p>
<b>Pension</b>	<ul style="list-style-type: none"> <li>Cash equivalent of 15% of salary for Group Chief Executive until 31 December 2022 and reducing to 8% from 1 January 2023 (in line with the majority of the UK workforce). The Group Finance Director's pension will increase from 6.5% to 8.0% of salary.</li> <li>Any new or promoted Executive Directors will have a pension contribution of 8.0% of salary, which is in line with the majority of the UK workforce.</li> </ul>
<b>Annual bonus</b>	<ul style="list-style-type: none"> <li>The maximum bonus opportunity will be 150% of salary for Group Chief Executive and 125% of salary for Group Finance Director.</li> <li>Target bonus opportunity is 50% of maximum.</li> <li>Performance metrics are based 60% on operating profit, 24% on simplified working capital, 8% on strategic objectives, and 8% on environmental, social and governance ("ESG") matters. Due to the close link between targets and the long-term strategy, the bonus targets for the year ending 31 March 2023 have not been disclosed in this report due to commercial sensitivity. However, further information on these bonus targets will be disclosed in next year's Annual Report and Accounts.</li> <li>Mandatory deferral of 20% of any bonus earned into discover E shares for a period of three years.</li> </ul>
<b>LTIP</b>	<ul style="list-style-type: none"> <li>LTIP awards for FY 2022/23 will be made in line with policy, with grant sizes of 175% of salary for the Group Chief Executive and 160% of salary for the Group Finance Director<sup>1</sup>. The Remuneration Committee has considered whether any adjustment to the award level is required as a result of share price movement and concluded that no adjustment is required, reflecting the Group's high growth over a multi-year period.</li> <li>Performance metrics and targets will be based 50% on underlying EPS growth and 50% on Relative TSR.</li> <li>The EPS range has been increased for the second consecutive year and will require growth of 5%p.a. for threshold vesting and 13%p.a. growth for full vesting. Vesting of the EPS element shall also be subject to an underpin requiring the Committee to be satisfied with the Group's annual rate of return on capital employed (ROCE) over the measurement period.</li> <li>The TSR peer group will be the FTSE 250 (excluding investment trusts). Threshold vesting (25%) will apply for median performance and full vesting (100%) will require upper quartile or higher.</li> </ul>
<b>Shareholding guidelines</b>	<ul style="list-style-type: none"> <li>A shareholding guideline of 200% of salary applies for the Group Chief Executive and Group Finance Director, to be achieved within five years and 250% after seven years.</li> </ul>

<sup>1</sup> Additional awards may be granted to the Group Finance Director in return for him bearing some of the Company's liability to Employer's National Insurance arising on the exercise of the grant referred to above. The additional award ensures that he is in a neutral position on an after-tax basis, assuming no change in the tax rate.

## DIRECTORS' REMUNERATION REPORT

The fees for the Non-Executive Directors increased with effect from 1 April 2022, as follows:

<b>As at 1 April 2022</b>	<b>Basic fee (£)</b>	<b>Committee Chair fee (£)</b>	<b>SID fee (£)</b>	<b>Total £</b>
Malcolm Diamond	156,000	–	–	156,000
Tracey Graham	50,000	10,000	–	60,000
Rosalind Kainyah	50,000	10,000	–	60,000
Bruce Thompson	50,000	–	10,000	60,000
Clive Watson	50,000	10,000	–	60,000

### Role of the Remuneration Committee

The Committee is responsible for considering and making recommendations to the Board on the remuneration of the Executive Directors. In doing so, it reports to the Board on how it has discharged its responsibilities and operates within agreed terms of reference which can be found on the Group's website.

The Committee also considers the recommendations of the Group Chief Executive with regard to the members of the Group Executive Committee who are not Executive Directors, in determining their remuneration packages, including bonuses, incentive payments, share options and other share-based awards. The Group Company Secretary provides administrative support.

### Advisers

During the year, the Committee received independent advice on executive remuneration from FIT Remuneration Consultants LLP ("FIT"). FIT were appointed by the Committee in 2019 following a competitive tender process. FIT is a signatory to the Remuneration Consultants' Code of Conduct. FIT does not provide any services other than advice to the Remuneration Committee and the Committee considers FIT to be independent and objective. The fees paid to FIT for advising the Committee for the financial year ended 31 March 2022 were £41,667 based partly on a fixed fee basis and partly based on time spent.

### Shareholder voting

<b>As at 1 April 2022</b>	<b>For<sup>1</sup></b>	<b>Against</b>	<b>Withheld<sup>2</sup></b>
2021 binding vote on the Directors' Remuneration Policy	69,269,506 94.65%	3,914,398 5.35%	117,514
2021 Approval of the Remuneration Report (excl. Policy)	71,560,905 97.78%	1,623,000 2.22%	117,513

<sup>1</sup> Includes votes at the Chairman's discretion

<sup>2</sup> A vote "withheld" is not a vote in law, and is not counted in the calculation of the proportion of votes for and against the resolution

## STATEMENT OF DIRECTORS' RESPONSIBILITIES IN RESPECT OF THE FINANCIAL STATEMENTS

The directors are responsible for preparing the Annual Report and the financial statements in accordance with applicable law and regulation.

Company law requires the directors to prepare financial statements for each financial year. Under that law the directors have prepared the group financial statements in accordance with UK-adopted international accounting standards and the company financial statements in accordance with United Kingdom Generally Accepted Accounting Practice (United Kingdom Accounting Standards, comprising FRS 101 "Reduced Disclosure Framework", and applicable law).

Under company law, directors must not approve the financial statements unless they are satisfied that they give a true and fair view of the state of affairs of the group and company and of the profit or loss of the group for that period. In preparing the financial statements, the directors are required to:

- select suitable accounting policies and then apply them consistently;
- state whether applicable UK-adopted international accounting standards have been followed for the group financial statements and United Kingdom Accounting Standards, comprising FRS 101 have been followed for the company financial statements, subject to any material departures disclosed and explained in the financial statements;
- make judgements and accounting estimates that are reasonable and prudent; and
- prepare the financial statements on the going concern basis unless it is inappropriate to presume that the group and company will continue in business.

The directors are responsible for safeguarding the assets of the group and company and hence for taking reasonable steps for the prevention and detection of fraud and other irregularities.

The directors are also responsible for keeping adequate accounting records that are sufficient to show and explain the group's and company's transactions and disclose with reasonable accuracy at any time the financial position of the group and company and enable them to ensure that the financial statements and the Directors' Remuneration Report comply with the Companies Act 2006.

The directors are responsible for the maintenance and integrity of the company's website. Legislation in the United Kingdom governing the preparation and dissemination of financial statements may differ from legislation in other jurisdictions.

### Directors' confirmations

The directors consider that the Annual Report and accounts, taken as a whole, is fair, balanced and understandable and provides the information necessary for shareholders to assess the group's and company's position and performance, business model and strategy.

Each of the directors, whose names and functions are listed in Corporate Governance report confirm that, to the best of their knowledge:

- the group financial statements, which have been prepared in accordance with UK-adopted international accounting standards, give a true and fair view of the assets, liabilities, financial position and profit of the group;
- the company financial statements, which have been prepared in accordance with United Kingdom Accounting Standards, comprising FRS 101, give a true and fair view of the assets, liabilities and financial position of the company; and
- the Strategic Report includes a fair review of the development and performance of the business and the position of the group and company, together with a description of the principal risks and uncertainties that it faces.



Financial Statements

## INDEPENDENT AUDITORS' REPORT TO THE MEMBERS OF discoverIE GROUP PLC

### Report on the audit of the financial statements

#### Opinion

In our opinion:

- discoverIE Group plc's group financial statements and Company Financial Statements (the "Financial Statements") give a true and fair view of the state of the Group's and of the Company's affairs as at 31 March 2022 and of the Group's profit and the Group's cash flows for the year then ended;
- the Group Financial Statements have been properly prepared in accordance with UK-adopted international accounting standards.
- the Company Financial Statements have been properly prepared in accordance with United Kingdom Generally Accepted Accounting Practice (United Kingdom Accounting Standards, comprising FRS 101 "Reduced Disclosure Framework", and applicable law); and
- the Financial Statements have been prepared in accordance with the requirements of the Companies Act 2006.

We have audited the Financial Statements, included within the Annual Report, which comprise: the consolidated Statement of Financial Position and the Company Statement of Financial Position as at 31 March 2022; the consolidated Statement of Profit or Loss, the consolidated Statement of Comprehensive Income, the consolidated and the Company Statement of Changes in Equity, and the consolidated Statement of Cash Flows for the year then ended; and the notes to the Group and Company Financial Statements, which include a description of the significant accounting policies.

Our opinion is consistent with our reporting to the Audit and Risk Committee.

#### Basis for opinion

We conducted our audit in accordance with International Standards on Auditing (UK) ("ISAs (UK)") and applicable law. Our responsibilities under ISAs (UK) are further described in the Auditors' responsibilities for the audit of the Financial Statements section of our report. We believe that the audit evidence we have obtained is sufficient and appropriate to provide a basis for our opinion.

#### Independence

We remained independent of the Group in accordance with the ethical requirements that are relevant to our audit of the Financial Statements in the UK, which includes the FRC's Ethical Standard, as applicable to listed public interest entities, and we have fulfilled our other ethical responsibilities in accordance with these requirements.

To the best of our knowledge and belief, we declare that non-audit services prohibited by the FRC's Ethical Standard were not provided.

Other than those disclosed in note 7 to the consolidated Financial Statements, we have provided no non-audit services to the company or its controlled undertakings in the period under audit.



### Our audit approach

#### Overview

#### Audit scope

- We conducted full scope audits at 20 components across the UK, Europe and Rest of the World and specific audit procedures on a further 11 components across the UK, Europe and Rest of the World.
- The components where we conducted audit procedures, together with work performed at the Group level, accounted for approximately 80% of the Group's revenue and 82% of the Group's absolute underlying profit before tax from continuing operations.
- Certain Company account balances were included in scope for the audit of the consolidated Financial Statements. However, we determined that the Company did not require a full scope audit of its complete financial information for the purposes of the audit of the consolidated Financial Statements.

#### Key audit matters

- Carrying value of goodwill (Group)
- Reporting of underlying adjustments (Group)
- Accounting for acquisitions and disposals (Group)
- Carrying value of investments (Company)

#### Materiality

- Overall Group materiality: £1,877,000 (2021: £1,574,400) based on 5% of the Group's underlying profit before tax from continuing operations.
- Overall Company materiality: £3,015,000 (2021: £1,417,000) based on 1% of total assets.
- Performance materiality: £1,407,000 (2021: £1,180,800) (Group) and £2,261,000 (2021: £1,062,700) (Company).

### The scope of our audit

As part of designing our audit, we determined materiality and assessed the risks of material misstatement in the Financial Statements.

#### Key audit matters

Key audit matters are those matters that, in the auditors' professional judgement, were of most significance in the audit of the Financial Statements of the current period and include the most significant assessed risks of material misstatement (whether or not due to fraud) identified by the auditors, including those which had the greatest effect on: the overall audit strategy; the allocation of resources in the audit; and directing the efforts of the engagement team. These matters, and any comments we make on the results of our procedures thereon, were addressed in the context of our audit of the Financial Statements as a whole, and in forming our opinion thereon, and we do not provide a separate opinion on these matters.

This is not a complete list of all risks identified by our audit.

Accounting for acquisitions and disposals is a new key audit matter this year. COVID-19 and going concern considerations, which was a key audit matter last year, is no longer included because of the Group's recovery from the effects of COVID-19 in the year, the diversified nature of the Group's operations and available liquidity and forecast covenant headroom over the going concern period. Otherwise, the key audit matters below are consistent with last year.



## INDEPENDENT AUDITORS' REPORT TO THE MEMBERS OF discoverIE GROUP PLC

Key audit matter	How our audit addressed the key audit matter
<p><b>Carrying value of goodwill (Group)</b> Refer to page 97 (Audit and Risk Committee Report), note 2 (Significant accounting judgements and estimates) and note 18 for the related disclosures on goodwill.</p> <p>The Group recorded £175.7 million of goodwill at 31 March 2022 (2021: £127.9 million).</p> <p>As required by IAS 36, management has performed its annual goodwill impairment assessment on the Group's cash generating units (CGUs).</p> <p>The carrying value of goodwill is dependent on future cash flows of the underlying CGUs which inherently involves significant management estimation and there is a risk that if management does not achieve these cash flow estimates it could give rise to impairment charges.</p> <p>The impairment assessment performed by management contains a number of significant assumptions principally relating to revenue growth rates, discount rates and future profitability. These assessments also include the estimated costs associated with the effects of climate change, including the future costs of the Group's target to reduce carbon emissions by 50% from 2019 levels by 2025.</p> <p>No impairment charge has been recorded in the year ended 31 March 2022.</p>	<p>We focused our work on the CGUs where the headroom between the value-in-use and the carrying value of the assets was lowest or those CGUs that were sensitive to changes in key assumptions.</p> <p>We obtained management's value-in-use impairment models and we tested the mathematical integrity. We compared the Group's year-end market capitalisation to management's value-in-use estimate for the Group as a whole and to the Group's net assets. We validated the carrying amounts of the net assets subject to impairment testing to the underlying accounting records, making sure that there was appropriate consistency between the assets and liabilities that were included in management's assessment and the related cash flows.</p> <p>We utilised our in-house valuation experts to evaluate the appropriateness of the methodology used in the impairment models, including challenging the discount rates and long-term growth rates. We compared the cash flows used in the impairment models to the Board approved budget, we challenged the assumptions underpinning the estimated costs associated with climate change; and we evaluated the determination of the Group's CGUs.</p> <p>We stress tested management's revenue growth, profit margin and head office cost allocation assumptions and we have separately benchmarked implied multiples required to cover the carrying value of net assets at each CGU to recent transaction multiples for acquired businesses. We considered external market data on growth in target markets. We challenged management's methodology and performed further sensitivities resulting in some changes to management's model. We also evaluated the historical accuracy of management's budgeting and forecasting and we compared the revenue growth and profit margins to historical actuals and modelled their break even points to assess whether further testing was required and whether additional disclosures should be provided in the Financial Statements.</p>



**Key audit matter**

**How our audit addressed the key audit matter**

**Carrying value of goodwill (group) - continued**

Where headroom was more sensitive to changes in key assumptions, we undertook further procedures. These included additional sensitivity analysis and testing of revenue growth rates to third party industry research. Where these CGUs were recently acquired, we have compared pre-acquisition performance to forecast results post acquisition.

Based on these procedures, we concluded that there was only one CGU where headroom was lower and where the CGU was sensitive to reasonably possible changes in key assumptions that could cause material impairment. Further procedures focused on this one CGU within the Sensing & Connectivity division; in particular the revenue growth rates, the discount rate, the long-term growth rate and future operating margins. We obtained a bridge of actual loss in FY22 to the forecast profit in FY23 and tested management's assumptions to a number of external sources including third party growth rates and other audit evidence, and we tested the non-recurring nature of a sample of one-off costs incurred in FY22.

We assessed the appropriateness of management's decision to provide additional disclosures about sensitivities in note 18 of the Financial Statements in relation to the one CGU within the Sensing & Connectivity division. More broadly, we considered whether the disclosures in note 18 complied with IAS 36.

Based on the procedures performed, we noted no material issues arising from our work.



## INDEPENDENT AUDITORS' REPORT TO THE MEMBERS OF discoverIE GROUP PLC

Key audit matter	How our audit addressed the key audit matter
<p><b>Reporting of underlying adjustments (Group)</b>                      Refer to Audit and Risk Committee Report page 97; Accounting policies (note 2); and note 6 (Underlying profit before tax).</p> <p>£20.5 million (2021: £13.7 million) of net costs are presented as adjustments to the Group's underlying profit before tax. These include:</p> <ul style="list-style-type: none"> <li>▪ £6.5 million of acquisition expenses; and</li> <li>▪ £14.0 million of amortisation of acquired intangible assets.</li> </ul> <p>The Group presents underlying performance measures on the face of the consolidated Statement of Profit or Loss as supplementary information.</p> <p>Management believes that the presentation of underlying performance measures provides investors with a means of evaluating the performance of the Group on a consistent basis, similar to the way in which management evaluates performance.</p> <p>The determination of which items are classified as adjustments to underlying profit is subject to judgement and therefore need to be classified appropriately and presented consistently.</p>	<p>We considered the appropriateness of the adjustments made to the statutory profit before tax to derive underlying performance.</p> <p>In order to do this, we considered:</p> <ul style="list-style-type: none"> <li>▪ The Group's accounting policy on non-underlying items.</li> <li>▪ The application of IFRS, in particular IAS 1; and</li> <li>▪ FRC Thematic Review on Alternative Performance Measures (APMs) issued in October 2021.</li> </ul> <p>We challenged management on the appropriateness of the classification of each item, having considered the nature of each item and that the basis for the classification is clearly disclosed and applied consistently from one year to the next.</p> <p>We also considered the risk that the Group's accounting policy could be manipulated to help achieve profit targets.</p> <p>We also considered the risk of one-off gains during the year not being properly identified and therefore presented inappropriately within underlying profit.</p> <p>Having considered the nature and quantum of these items, overall, we were satisfied that the classification of adjustments to the Group's underlying profit in the consolidated Financial Statements for the year ended 31 March 2022 was appropriate and consistently applied.</p>



### Key audit matter

#### Accounting for acquisitions and disposals (Group)

Refer to Audit and Risk Committee Report page 97; Accounting policies (note 2); note 11 (business combinations) and note 12 (discontinued operations and assets held for sale).

In FY 2021/22, the Group acquired 3 businesses (FY 2020/21: 2 businesses) for total consideration of £89.2m (FY 2020/21: £22.3m). Goodwill of £52.9m (FY 2020/21: £9.9m) and customer relationships and other intangible assets totalling £37.7m (FY 2020/21: £9.8m) were recorded.

The valuation of the customer relationships requires management estimation as it is dependent on estimates of future cash flows, customer attrition rates and discount rates.

In FY22, the Group exited its distribution business by completing the disposal of Acal BFi and Vertec Scientific SA Proprietary Limited.

The Acal BFi disposal generated net consideration of £42.6m, with Vertec Scientific SA Proprietary Limited generating net consideration of £2.2m. The combined profit on disposal was £6.6m.

Accounting for disposals (specifically the Acal BFi business given its size) is complex and needs to be accounted for and disclosed in the consolidated Financial Statements in accordance with the requirements of IFRS 5.

### How our audit addressed the key audit matter

We tested each of the three acquisitions in the year. We utilised our in-house valuation experts to evaluate the appropriateness of the methodology used to value customer relationships and to test the appropriateness of the discount rates. We compared the customer termination rates and future cash flows to historical data and to the approved acquisition business cases and we performed sensitivities on these estimates.

We considered the disclosures in note 11 of the consolidated Financial Statements and we are satisfied that these disclosures are appropriate. Based on the procedures performed, we noted no material issues arising from our work on acquisitions.

Our work on disposals focused on Acal BFi given its size. We determined whether the business met the definition of discontinued operations (for disposals) in accordance with the applicable framework, IFRS 5; and we tested the gain recognised on disposal. We challenged management on the date of deconsolidation of the Acal business. We tested the consideration paid and the fair value of deferred consideration. We also tested on a sample basis the transactions in the period prior to disposal.

We reviewed the disclosures in note 12 of the consolidated Financial Statements to ensure these are in line with relevant accounting requirements; and we specifically assessed the classification of profits between operating activities prior to disposal and the gain on disposal.

Based on the procedures performed, we noted no material issues arising from our work on disposals.

# INDEPENDENT AUDITORS' REPORT TO THE MEMBERS OF discoverIE GROUP PLC

Key audit matter	How our audit addressed the key audit matter
<p><b>Carrying value of investments (Company)</b>                      Refer to note 2 (Judgement and key sources of estimation uncertainty) and note 5 of the Company Financial Statements for the related disclosures on the carrying value of investments.</p> <p>The Company holds investments in its subsidiaries of £203.4 million (2021: £201.3m).</p> <p>We focused on this area due to the size of the investment balances with a focus on the risk of impairment arising in company's investments in two entities with a carrying value of £18.5m and £25.7m respectively including the Group's service company that derives revenue from intercompany recharges.</p> <p>Management has performed an assessment of the recoverable amount of the investments and compared this to the carrying value using the same cash flow methodology applied in the impairment test for goodwill described above.</p> <p>No impairment charge has been recorded in the year ended 31 March 2022.</p>	<p>We evaluated management's assessment of whether any indicators of impairment existed, which included comparing the carrying values of investments in subsidiaries with their net assets at 31 March 2022.</p> <p>For investments where an indicator of impairment was noted, including where the net assets were lower than the carrying values, we assessed their recoverable value by reference to the value in use of the investments compared to their carrying values at 31 March 2022. Where applicable, we verified that the recoverable values of investments were consistent with the recoverable values of the related CGUs tested for goodwill impairment purposes, leveraging the audit work undertaken as part of the Group audit.</p> <p>We performed sensitivity analysis on the key assumptions within the cash flow forecasts. This included sensitising the discount rate applied to the future cash flows, and the short and longer term growth rates and operating income forecasts.</p> <p>We assessed the appropriateness of management's decision to provide additional disclosures about sensitivities in note 5 of the Company Financial Statements in relation to the Company's investment with the carrying value of £18.5m. More broadly, we considered whether the disclosures in note 5 complied with relevant accounting requirements.</p> <p>Based on the procedures performed, we noted no material issues arising from our work.</p>
<p><b>How we tailored the audit scope</b>                      We tailored the scope of our audit to ensure that we performed enough work to be able to give an opinion on the Financial Statements as a whole, taking into account the structure of the Group and the Company, the accounting processes and controls, and the industry in which they operate.</p> <p>We performed full scope audits and specific audit procedures at 31 components across the UK, Europe and Rest of the World which were selected based on their size or risk characteristics of which 4 entities were brought into Group audit scope in FY22. Of these, we identified 4 material components in the UK, 6 in Europe and 1 in Rest of the World. No components were identified as being financially significant. The remainder of the full scope components and specified procedures components were included in Group audit scope to achieve sufficient coverage and to address specific risk characteristics.</p>	<p>In establishing the overall approach to the Group audit, we determined the type of work that needed to be performed by us, as the Group engagement team, or by component auditors within PwC UK and from other PwC network firms operating under our instruction. Where the work was performed by component auditors, we determined the level of involvement we needed to have in the audit work at those components to be able to conclude whether sufficient appropriate audit evidence had been obtained as a basis for our opinion on the consolidated Financial Statements as a whole.</p> <p>In addition to instructing and reviewing the reporting from our component audit teams, we conducted file reviews for material components and participated in key meetings with component audit teams and had regular dialogue with component teams throughout the year.</p>



The Group consolidation, Financial Statement disclosures and corporate functions were audited by the Group engagement team. This included our work over taxation, goodwill, acquisition accounting and retirement benefit obligations. Taken together, the components and corporate functions where we conducted audit procedures accounted for approximately: 80% (2021: 75%) of the Group's revenue and 82% (2021: 81%) of the Group's absolute underlying profit before tax from continuing operations. This provided the evidence we needed for our opinion on the consolidated Financial Statements taken as a whole. This was before considering the contribution to our audit evidence from performing audit work at the Group level, including disaggregated analytical review procedures, which covered certain of the Group's smaller and lower risk components that were not directly included in our Group audit scope.

Our audit of the Company Financial Statements was undertaken in the UK and included substantive procedures over all material balances and transactions.

As part of the audit, we enquired of management to understand and evaluate the Group's risk assessment process in relation to climate change. We reviewed management's paper which sets out

### Materiality

The scope of our audit was influenced by our application of materiality. We set certain quantitative thresholds for materiality. These, together with qualitative considerations, helped us to determine the scope of our audit and the nature, timing and extent of our audit procedures on the individual financial statement line items and disclosures and in evaluating the effect of misstatements, both individually and in aggregate on the Financial Statements as a whole.

Based on our professional judgement, we determined materiality for the Financial Statements as a whole as follows:

	Financial Statements - Group	Financial Statements - Company
<b>Overall materiality</b>	£1,877,000 (2021: £1,574,400).	£3,015,000 (2021: £1,417,000).
<b>How we determined it</b>	5% of underlying profit before tax from continuing operations of the Group	1% of total assets
<b>Rationale for benchmark applied</b>	We believe that underlying profit before tax from continued operations provides a consistent year on year basis for determining materiality and is the most relevant performance measure to the key stakeholders of the Group.	We believe that total assets is the most appropriate measure to assess a holding company, and is a generally accepted auditing benchmark.

their assessment of climate change risk to the Group and the impact on the Financial Statements. In evaluating the completeness of the risks identified, we engaged our internal climate change experts to assist us in reviewing management's assessment and challenged management on how they considered the potential financial impacts of the Group's carbon reduction target in their assessment. We considered the key risk to relate to the assumptions made in the forecast prepared by management and used in their assessment of the carrying value of goodwill. In responding to the risks identified, we specifically considered how climate change risk would impact these assumptions including the future costs of the Group's target to reduce carbon emissions by 50% from 2019 levels by 2025 as discussed in the carrying value of goodwill key audit matter. We also read the disclosures in relation to climate change made in the Sustainability Report and Risk Management sections of the Annual Report to ascertain whether the disclosures are materially consistent with the Financial Statements and our knowledge from our audit. Our responsibility over other information is further described in the "reporting on other information" section of this report.



Financial Statements

## INDEPENDENT AUDITORS' REPORT TO THE MEMBERS OF discoverIE GROUP PLC

For each component in the scope of our group audit, we allocated a materiality that is less than our overall Group materiality. The range of materiality allocated across components was £126,000 to £1,497,000. Certain components were audited to a local statutory audit materiality that was also less than our overall Group materiality.

We use performance materiality to reduce to an appropriately low level the probability that the aggregate of uncorrected and undetected misstatements exceeds overall materiality. Specifically, we use performance materiality in determining the scope of our audit and the nature and extent of our testing of account balances, classes of transactions and disclosures, for example in determining sample sizes. Our performance materiality was 75% (2021: 75%) of overall materiality, amounting to £1,407,000 (2021: £1,180,800) for the Group Financial Statements and £2,261,000 (2021: £1,062,700) for the Company Financial Statements.

In determining the performance materiality, we considered a number of factors - the history of misstatements, risk assessment and aggregation risk and the effectiveness of controls - and concluded that an amount at the upper end of our normal range was appropriate.

We agreed with the Audit and Risk Committee that we would report to them misstatements identified during our audit above £85,000 (Group audit) (2021: £78,720) and £150,750 (Company audit) (2021: £78,720) as well as misstatements below those amounts that, in our view, warranted reporting for qualitative reasons.

### Conclusions relating to going concern

Our evaluation of the directors' assessment of the Group's and the Company's ability to continue to adopt the going concern basis of accounting included:

- Evaluation of management's base case and downside case scenarios, understanding and evaluating the key assumptions.
- Validation that the cash flow forecasts used to support management's impairment, going concern and viability assessments were consistent;
- Assessment of the historical accuracy and reasonableness of management's forecasting.
- Consideration of the Group's available financing and debt maturity profile;

- Testing of the mathematical integrity of management's liquidity headroom, sensitivity and stress testing calculations.
- Undertaking independent sensitivities;
- Assessment of the reasonableness of management's planned or potential mitigating actions; and
- Review of the related disclosures in the Financial Statements.

Based on the work we have performed, we have not identified any material uncertainties relating to events or conditions that, individually or collectively, may cast significant doubt on the Group's and the Company's ability to continue as a going concern for a period of at least twelve months from when the Financial Statements are authorised for issue.

In auditing the Financial Statements, we have concluded that the directors' use of the going concern basis of accounting in the preparation of the Financial Statements is appropriate.

However, because not all future events or conditions can be predicted, this conclusion is not a guarantee as to the Group's and the Company's ability to continue as a going concern.

In relation to the directors' reporting on how they have applied the UK Corporate Governance Code, we have nothing material to add or draw attention to in relation to the directors' statement in the Financial Statements about whether the directors considered it appropriate to adopt the going concern basis of accounting.

Our responsibilities and the responsibilities of the directors with respect to going concern are described in the relevant sections of this report.

### Reporting on other information

The other information comprises all of the information in the Annual Report other than the Financial Statements and our auditors' report thereon. The directors are responsible for the other information, which includes reporting based on the Task Force on Climate-related Financial Disclosures (TCFD) recommendations. Our opinion on the Financial Statements does not cover the other information and, accordingly, we do not express an audit opinion or, except to the extent otherwise explicitly stated in this report, any form of assurance thereon.



In connection with our audit of the Financial Statements, our responsibility is to read the other information and, in doing so, consider whether the other information is materially inconsistent with the Financial Statements or our knowledge obtained in the audit, or otherwise appears to be materially misstated. If we identify an apparent material inconsistency or material misstatement, we are required to perform procedures to conclude whether there is a material misstatement of the Financial Statements or a material misstatement of the other information. If, based on the work we have performed, we conclude that there is a material misstatement of this other information, we are required to report that fact. We have nothing to report based on these responsibilities.

With respect to the Strategic report and Directors' report, we also considered whether the disclosures required by the UK Companies Act 2006 have been included.

Based on our work undertaken in the course of the audit, the Companies Act 2006 requires us also to report certain opinions and matters as described below.

### Strategic report and Directors' report

In our opinion, based on the work undertaken in the course of the audit, the information given in the Strategic report and Directors' report for the year ended 31 March 2022 is consistent with the Financial Statements and has been prepared in accordance with applicable legal requirements.

In light of the knowledge and understanding of the Group and Company and their environment obtained in the course of the audit, we did not identify any material misstatements in the Strategic report and Directors' Report.

### Directors' remuneration

In our opinion, the part of the Directors' remuneration report to be audited has been properly prepared in accordance with the Companies Act 2006.

### Corporate governance statement

The Listing Rules require us to review the directors' statements in relation to going concern, longer-term viability and that part of the corporate governance statement relating to the Company's compliance with the provisions of the UK Corporate Governance Code specified for our review. Our additional responsibilities with respect to the corporate governance statement as other information are described in the Reporting on other information section of this report.

Based on the work undertaken as part of our audit, we have concluded that each of the following elements of the corporate governance statement is materially consistent with the Financial Statements and our knowledge obtained during the audit, and we have nothing material to add or draw attention to in relation to:

- The directors' confirmation that they have carried out a robust assessment of the emerging and principal risks;
- The disclosures in the Annual Report that describe those principal risks, what procedures are in place to identify emerging risks and an explanation of how these are being managed or mitigated;
- The directors' statement in the Financial Statements about whether they considered it appropriate to adopt the going concern basis of accounting in preparing them, and their identification of any material uncertainties to the Group's and Company's ability to continue to do so over a period of at least twelve months from the date of approval of the Financial Statements;
- The directors' explanation as to their assessment of the Group's and Company's prospects, the period this assessment covers and why the period is appropriate; and
- The directors' statement as to whether they have a reasonable expectation that the Company will be able to continue in operation and meet its liabilities as they fall due over the period of its assessment, including any related disclosures drawing attention to any necessary qualifications or assumptions.

Our review of the directors' statement regarding the longer-term viability of the Group was substantially less in scope than an audit and only consisted of making inquiries and considering the directors' process supporting their statement; checking that the statement is in alignment with the relevant provisions of the UK Corporate Governance Code; and considering whether the statement is consistent with the Financial Statements and our knowledge and understanding of the Group and Company and their environment obtained in the course of the audit.

In addition, based on the work undertaken as part of our audit, we have concluded that each of the following elements of the corporate governance statement is materially consistent with the Financial Statements and our knowledge obtained during the audit:



Financial Statements

## INDEPENDENT AUDITORS' REPORT TO THE MEMBERS OF discoverIE GROUP PLC

- The directors' statement that they consider the Annual Report, taken as a whole, is fair, balanced and understandable, and provides the information necessary for the members to assess the Group's and Company's position, performance, business model and strategy;
- The section of the Annual Report that describes the review of effectiveness of risk management and internal control systems; and
- The section of the Annual Report describing the work of the Audit and Risk Committee.

We have nothing to report in respect of our responsibility to report when the directors' statement relating to the Company's compliance with the Code does not properly disclose a departure from a relevant provision of the Code specified under the Listing Rules for review by the auditors.

### Responsibilities for the Financial Statements and the audit

#### Responsibilities of the directors for the Financial Statements

As explained more fully in the Statement of Directors' Responsibilities in Respect of the Financial Statements, the directors are responsible for the preparation of the Financial Statements in accordance with the applicable framework and for being satisfied that they give a true and fair view. The directors are also responsible for such internal control as they determine is necessary to enable the preparation of Financial Statements that are free from material misstatement, whether due to fraud or error.

In preparing the Financial Statements, the directors are responsible for assessing the Group's and the Company's ability to continue as a going concern, disclosing, as applicable, matters related to going concern and using the going concern basis of accounting unless the directors either intend to liquidate the Group or the Company or to cease operations, or have no realistic alternative but to do so.

#### Auditors' responsibilities for the audit of the Financial Statements

Our objectives are to obtain reasonable assurance about whether the Financial Statements as a whole are free from material misstatement, whether due to fraud or error, and to issue an auditors' report that includes our opinion. Reasonable assurance is a high level of assurance, but is not a guarantee that an audit conducted in accordance with ISAs (UK) will always detect a material misstatement when it

exists. Misstatements can arise from fraud or error and are considered material if, individually or in the aggregate, they could reasonably be expected to influence the economic decisions of users taken on the basis of these Financial Statements.

Irregularities, including fraud, are instances of non-compliance with laws and regulations. We design procedures in line with our responsibilities, outlined above, to detect material misstatements in respect of irregularities, including fraud. The extent to which our procedures are capable of detecting irregularities, including fraud, is detailed below.

Based on our understanding of the Group and industry, we identified that the principal risks of non-compliance with laws and regulations related to the listing rules, the Waste Electrical and Electronic Equipment Regulations 2006 directive and local laws and regulations applicable in the territories that the Group operates in, and we considered the extent to which non-compliance might have a material effect on the Financial Statements. We also considered those laws and regulations that have a direct impact on the Financial Statements such as Companies Act 2006 and taxation. We evaluated management's incentives and opportunities for fraudulent manipulation of the financial statements (including the risk of override of controls), and determined that the principal risks were related to posting of unusual journals to increase revenue and management bias in determining accounting estimates. The Group engagement team shared this risk assessment with the component auditors so that they could include appropriate audit procedures in response to such risks in their work. Audit procedures performed by the Group engagement team and/or component auditors included:

- Discussions with management, Internal Audit and the Audit and Risk Committee, including consideration of known or suspected instances of non-compliance with laws and regulation and fraud;
- Evaluation of the effectiveness of management's controls designed to prevent and detect irregularities;
- Identification and testing of significant manual journal entries;
- Assessment of matters reported on the Group's whistleblowing helpline and the results of management's investigation of such matters;



- Testing of assumptions and judgements made by management in making significant accounting estimates; and
- Reviewing Financial Statement disclosures and testing the disclosures to supporting evidence.

There are inherent limitations in the audit procedures described above. We are less likely to become aware of instances of non-compliance with laws and regulations that are not closely related to events and transactions reflected in the Financial Statements. Also, the risk of not detecting a material misstatement due to fraud is higher than the risk of not detecting one resulting from error, as fraud may involve deliberate concealment by, for example, forgery or intentional misrepresentations, or through collusion.

Our audit testing might include testing complete populations of certain transactions and balances, possibly using data auditing techniques. However, it typically involves selecting a limited number of items for testing, rather than testing complete populations. We will often seek to target particular items for testing based on their size or risk characteristics. In other cases, we will use audit sampling to enable us to draw a conclusion about the population from which the sample is selected.

A further description of our responsibilities for the audit of the Financial Statements is located on the FRC's website at: [www.frc.org.uk/auditorsresponsibilities](http://www.frc.org.uk/auditorsresponsibilities). This description forms part of our auditors' report.

### Use of this report

This report, including the opinions, has been prepared for and only for the Company's members as a body in accordance with Chapter 3 of Part 16 of the Companies Act 2006 and for no other purpose. We do not, in giving these opinions, accept or assume responsibility for any other purpose or to any other person to whom this report is shown or into whose hands it may come save where expressly agreed by our prior consent in writing.

## Other required reporting

### Companies Act 2006 exception reporting

Under the Companies Act 2006 we are required to report to you if, in our opinion:

- we have not obtained all the information and explanations we require for our audit; or
- adequate accounting records have not been kept by the Company, or returns adequate for our audit have not been received from branches not visited by us; or
- certain disclosures of directors' remuneration specified by law are not made; or
- the Company Financial Statements and the part of the Directors' remuneration report to be audited are not in agreement with the accounting records and returns.

We have no exceptions to report arising from this responsibility.

### Appointment

Following the recommendation of the Audit and Risk Committee, we were appointed by the directors on 13 July 2017 to audit the Financial Statements for the year ended 31 March 2018 and subsequent financial periods. The period of total uninterrupted engagement is 5 years, covering the years ended 31 March 2018 to 31 March 2022.

## Other matter

As required by the Financial Conduct Authority Disclosure Guidance and Transparency Rule 4.1.14R, these Financial Statements form part of the ESEF-prepared annual financial report filed on the National Storage Mechanism of the Financial Conduct Authority in accordance with the ESEF Regulatory Technical Standard ('ESEF RTS'). This auditors' report provides no assurance over whether the annual financial report has been prepared using the single electronic format specified in the ESEF RTS.

### Christopher Hibbs (Senior Statutory Auditor)

for and on behalf of PricewaterhouseCoopers LLP  
Chartered Accountants and Statutory Auditors  
London  
14 June 2022



Financial Statements

## CONSOLIDATED STATEMENT OF PROFIT OR LOSS

for the year ended 31 March 2022

	notes	2022 £m	2021 restated* £m
<b>Continuing operations</b>			
Revenue	4	<b>379.2</b>	302.8
Operating costs		<b>(358.3)</b>	(285.7)
<b>Operating profit</b>	7	<b>20.9</b>	17.1
Finance income	9	<b>0.4</b>	0.3
Finance costs	9	<b>(4.2)</b>	(3.9)
<b>Profit before tax</b>		<b>17.1</b>	13.5
Tax expense	10	<b>(7.4)</b>	(4.0)
<b>Profit for the year from continuing operations</b>		<b>9.7</b>	9.5
<b>Discontinued operations</b>			
Profit for the year from discontinued operations	12	<b>15.5</b>	2.5
<b>Profit for the year</b>		<b>25.2</b>	12.0
<b>Earnings per share</b>			
	14		
Basic, profit from continuing operations		<b>10.4p</b>	10.7p
Diluted, profit from continuing operations		<b>10.1p</b>	10.3p
Basic, profit for the year		<b>27.1p</b>	13.5p
Diluted, profit for the year		<b>26.3p</b>	13.0p

## SUPPLEMENTARY STATEMENT OF PROFIT OR LOSS INFORMATION

	notes	2022 £m	2021 restated* £m
<b>Underlying Performance Measures (continuing operations)</b>			
Operating profit	7	<b>20.9</b>	17.1
Add back: Acquisition expenses	6	<b>6.5</b>	1.2
Amortisation of acquired intangible assets	19	<b>14.0</b>	11.1
IAS 19 pension charge	32	<b>-</b>	1.4
<b>Underlying operating profit</b>		<b>41.4</b>	30.8
Profit before tax		<b>17.1</b>	13.5
Add back: Acquisition expenses	6	<b>6.5</b>	1.2
Amortisation of acquired intangible assets	19	<b>14.0</b>	11.1
IAS 19 pension charge	32	<b>-</b>	1.4
<b>Underlying profit before tax</b>		<b>37.6</b>	27.2
<b>Underlying earnings per share</b>	14	<b>29.4p</b>	22.4p

\* 2021 restated. Refer to note 2 to the consolidated Financial Statements.



## CONSOLIDATED STATEMENT OF COMPREHENSIVE INCOME

for the year ended 31 March 2022

	notes	2022 £m	2021 £m
<b>Profit for the year</b>		<b>25.2</b>	12.0
Other comprehensive income/(loss):			
<i>Items that will not be subsequently reclassified to profit or loss:</i>			
Actuarial gain/(loss) on defined benefit pension scheme	32	2.2	(3.4)
Deferred tax (charge)/credit relating to defined benefit pension scheme	10	(0.5)	0.6
		1.7	(2.8)
<i>Items that may be subsequently reclassified to profit or loss:</i>			
Exchange differences on translation of foreign subsidiaries		9.6	(0.5)
Reclassification of exchange differences on disposal of businesses	12	(2.0)	–
		7.6	(0.5)
<b>Other comprehensive income/(loss) for the year, net of tax</b>		<b>9.3</b>	(3.3)
<b>Total comprehensive income for the year, net of tax</b>		<b>34.5</b>	8.7



Financial Statements

## CONSOLIDATED STATEMENT OF FINANCIAL POSITION

as at 31 March 2022

	notes	2022 £m	2021 restated* £m
<b>Non-current assets</b>			
Property, plant and equipment	15	23.5	23.5
Intangible assets – goodwill	17	175.7	127.9
Intangible assets – other	19	87.6	62.9
Right of use assets	16	21.9	22.4
Pension asset	32	2.7	–
Other receivables	21	5.9	–
Deferred tax assets	10	9.2	7.9
		<b>326.5</b>	<b>244.6</b>
<b>Current assets</b>			
Inventories	20	77.8	67.7
Trade and other receivables	21	78.0	84.9
Current tax assets		1.6	1.8
Cash and cash equivalents	22	39.4	29.2
		<b>196.8</b>	<b>183.6</b>
<b>Total assets</b>		<b>523.3</b>	<b>428.2</b>
<b>Current liabilities</b>			
Trade and other payables	29	(104.8)	(94.8)
Other financial liabilities	23	(2.0)	(0.8)
Lease liabilities	16	(4.7)	(4.8)
Current tax liabilities		(7.7)	(5.6)
Provisions	26	(1.7)	(1.8)
		<b>(120.9)</b>	<b>(107.8)</b>
<b>Non-current liabilities</b>			
Trade and other payables	29	(2.7)	(0.8)
Other financial liabilities	23	(67.6)	(75.6)
Lease liabilities	16	(16.4)	(16.7)
Pension liability	32	–	(1.0)
Provisions	26	(4.2)	(5.4)
Deferred tax liabilities	10	(21.1)	(12.5)
		<b>(112.0)</b>	<b>(112.0)</b>
<b>Total liabilities</b>		<b>(232.9)</b>	<b>(219.8)</b>
<b>Net assets</b>		<b>290.4</b>	<b>208.4</b>
<b>Equity</b>			
Share capital	30	4.7	4.4
Share premium		192.0	138.8
Merger reserve		10.5	19.9
Currency translation reserve		4.9	(2.7)
Retained earnings		78.3	48.0
<b>Total equity</b>		<b>290.4</b>	<b>208.4</b>

\* 2021 restated. Refer to note 2 to the consolidated Financial Statements.

The Financial Statements on pages 146 to 212 were approved by the Board of Directors on 14 June 2022 and signed on its behalf by:

**Nick Jefferies**  
Group Chief Executive

**Simon Gibbins**  
Group Finance Director



## CONSOLIDATED STATEMENT OF CHANGES IN EQUITY

for the year ended 31 March 2022

	Attributable to equity holders of the Company					
	Share capital £m	Share premium £m	Merger reserve £m	Currency translation reserve £m	Retained earnings £m	Total equity £m
<b>At 1 April 2020</b>	<b>4.4</b>	<b>138.8</b>	<b>22.7</b>	<b>(2.2)</b>	<b>36.8</b>	<b>200.5</b>
Prior year restatement (note 2)	–	–	–	–	(0.4)	(0.4)
<b>At 1 April 2020 (restated)</b>	<b>4.4</b>	<b>138.8</b>	<b>22.7</b>	<b>(2.2)</b>	<b>36.4</b>	<b>200.1</b>
Profit for the year	–	–	–	–	12.0	12.0
Other comprehensive loss	–	–	–	(0.5)	(2.8)	(3.3)
Total comprehensive income	–	–	–	(0.5)	9.2	8.7
Share-based payments including tax	–	–	–	–	2.4	2.4
Transfer to retained earnings	–	–	(2.8)	–	2.8	–
Dividends (note 13)	–	–	–	–	(2.8)	(2.8)
<b>At 31 March 2021 (restated)</b>	<b>4.4</b>	<b>138.8</b>	<b>19.9</b>	<b>(2.7)</b>	<b>48.0</b>	<b>208.4</b>
Profit for the year	–	–	–	–	25.2	25.2
Other comprehensive income	–	–	–	7.6	1.7	9.3
Total comprehensive income	–	–	–	7.6	26.9	34.5
Shares issued (note 30)	0.3	53.2	–	–	–	53.5
Share-based payments including tax	–	–	–	–	3.4	3.4
Transfer to retained earnings	–	–	(9.4)	–	9.4	–
Dividends (note 13)	–	–	–	–	(9.4)	(9.4)
<b>At 31 March 2022</b>	<b>4.7</b>	<b>192.0</b>	<b>10.5</b>	<b>4.9</b>	<b>78.3</b>	<b>290.4</b>



Financial Statements

## CONSOLIDATED STATEMENT OF CASH FLOWS

for the year ended 31 March 2022

	notes	2022 £m	2021 £m
<b>Net cash flow from operating activities</b>	25	<b>30.9</b>	46.0
<b>Investing activities</b>			
Acquisition of businesses, net of cash acquired		<b>(84.5)</b>	(20.8)
Business disposal proceeds	12	<b>37.3</b>	–
Purchase of property, plant and equipment		<b>(5.4)</b>	(3.2)
Purchase of intangible assets – software		<b>(0.8)</b>	(0.7)
Proceeds from disposal of property, plant and equipment		<b>0.4</b>	0.3
Interest received		<b>0.4</b>	0.3
<b>Net cash used in investing activities</b>		<b>(52.6)</b>	(24.1)
<b>Financing activities</b>			
Net proceeds from the issue of shares		<b>53.4</b>	0.1
Proceeds from borrowings	24	<b>94.1</b>	9.3
Repayment of borrowings	24	<b>(102.3)</b>	(27.8)
Payment of lease liabilities		<b>(6.4)</b>	(6.1)
Cash-settled share-based payments		<b>(0.1)</b>	–
Dividends paid	13	<b>(9.4)</b>	(2.8)
<b>Net cash generated from/(used in) financing activities</b>		<b>29.3</b>	(27.3)
<b>Net increase/(decrease) in cash and cash equivalents<sup>1</sup></b>		<b>7.6</b>	(5.4)
Net cash and cash equivalents at 1 April		<b>28.2</b>	34.8
Effect of exchange rate fluctuations		<b>1.1</b>	(1.2)
<b>Net cash and cash equivalents at 31 March</b>		<b>36.9</b>	28.2
<b>Reconciliation to cash and cash equivalents in the consolidated statement of financial position</b>			
Net cash and cash equivalents shown above		<b>36.9</b>	28.2
Add back: bank overdrafts	23	<b>2.5</b>	1.0
Cash and cash equivalents presented in current assets in the consolidated statement of financial position	22	<b>39.4</b>	29.2

<sup>1</sup> Further information on the consolidated statement of cash flows is provided in notes 24 and 25.



# NOTES TO THE GROUP FINANCIAL STATEMENTS

for the year ended 31 March 2022

## 1. Reporting Entity and Authorisation of Financial Statements

The consolidated Financial Statements, which comprise the results of discoverIE Group plc ('the Company') and its subsidiaries (collectively referred to as 'the Group'), for the year ended 31 March 2022 were authorised for issue by the Board of Directors on 14 June 2022. discoverIE Group plc is a public limited company incorporated and domiciled in England, UK and the registered office is disclosed on page 207. The Company's ordinary shares are traded on the London Stock Exchange.

The significant accounting policies adopted by the Group are set out in note 2 and have been applied consistently to all years presented in these consolidated Financial Statements.

## 2. Accounting policies Statement of Compliance

On 31 December 2020, IFRS as adopted by the European Union at that date was brought into UK law and became UK-adopted International Accounting Standards, with future changes being subject to endorsement by the UK Endorsement Board. The Group transitioned to UK-adopted International Accounting Standards in its consolidated Financial Statements on 1 April 2021. This change constitutes a change in accounting framework. However, there is no impact on recognition, measurement or disclosure in the period reported as a result of the change in framework.

The Group's consolidated Financial Statements have been prepared and approved by the Directors in accordance with UK-adopted International Accounting Standards (UK-adopted IAS) and with requirements of the Companies Act 2006 applicable to companies reporting under those standards.

The separate Financial Statements of the Company have been prepared and approved by the Directors in accordance with Financial Reporting Standard 101 'Reduced Disclosure Framework' (FRS 101). On publishing the Company's Financial Statements here together with the Group's Financial Statements, the Company is taking advantage of the exemption in section 408 of the Companies Act 2006 not to present its individual Statement of Profit or Loss and related notes that form a part of these approved Financial Statements.

The following exemptions from the requirements of the UK-adopted IAS have been applied in the preparation of the Company's Financial Statements, in accordance with FRS 101:

- Cash Flow Statement and respective disclosures and information;
- Disclosure in relation to capital management;
- Disclosures in relation to financial instruments;
- Disclosures in respect of the compensation of key management personnel;
- Disclosures in respect of transactions between two or more members of the Group.

For the following disclosures, as the Group's consolidated Financial Statements include the equivalent disclosures, the Company has taken the exemptions available under FRS 101:

- IFRS 2 Share-based payments in respect of group settled equity share-based payments;
- Certain disclosures required by IFRS 13 Fair Value Measurement.

## Basis of preparation

The Group Financial Statements and the Company Financial Statements are prepared under the historical cost convention, unless otherwise stated.

The Group and Company Financial Statements are presented in pounds sterling and all values are rounded to the nearest hundred thousand except as otherwise indicated.

The Group has engaged in an ongoing review of expected climate change impacts on the business and its assets and liabilities to establish any adjustments required and what reporting is necessary in its Financial Statements for 2022. The ongoing risk assessment is detailed within the climate related risks and opportunities section on pages 46 to 50 of the Risk Management section and on pages 67 to 69 of the Sustainability Report in the Strategic Report section.



Financial Statements

## NOTES TO THE GROUP FINANCIAL STATEMENTS

for the year ended 31 March 2022

### 2. Accounting policies continued

The process has involved a review of all balance sheet line items and future cash flows, to identify if any of these items is expected to be materially impacted in a negative or positive way by weather, legislative, societal or revenue/cost changes.

The conclusion of the review was that, while there will undoubtedly be impacts on the Group, the highly disaggregated nature of the operations of the Group and the target markets the Group operates in significantly reduces the risk profile of the Group to impacts from weather-related changes. The changes necessary to achieve the 50% reduction in carbon emission from 2019 level is not expected to have a materially adverse impact on the cash flows of the Group and indeed, warmer climates may present enhanced opportunities in our target markets as disclosed on page 46 to 50 of this report. Societal and legislative impacts are not considered to have a material impact on any one segment such that we need to break out reporting in a different way to previous years. Judgements are not considered to be significant, although clearly understanding of climate change is developing with time. The area with the most judgement is goodwill impairment testing and a description is given in note 18 of the incremental processes undertaken to assess the climate change impact on the valuations. Management review has concluded that there is no material impact and that no further disclosure is required.

### Going concern

In line with IAS1 'Presentation of Financial Statements' and revised guidance on 'risk management, internal control and related financial and business reporting', management has taken into account all available information about the future for a period of at least, but not limited to, 12 months from the date of approval of the Financial Statements when assessing the Group's and Company's ability to continue as a going concern.

The Group's business activities, together with factors which may adversely impact its future development, performance and position, are set out in the Strategic Report on pages 02 to 81. The financial position of the Group, its cash flows, liquidity position and borrowing facilities are described in the Finance Review section of the Strategic Report on pages 36 to 41.

The Group's forecasts and projections, taking account of the sensitivity analysis of changes in trading performance, show that the Group is well placed to operate within its current committed facilities of £240m for the foreseeable future.

The Viability Base Case, as stated on pages 52 to 53 has been subjected to sensitivity analysis involving flexing a number of the underlying main assumptions, both individually and in conjunction. The sensitivities take into account the principal risks and uncertainties set out on pages 54 to 59, notably instability in the economic environment, underperformance of acquired businesses, climate related risks, loss of key customers and suppliers, major business disruption, liquidity restriction, liquidity and debt covenants and adverse foreign currency movements.

The most severe but plausible downside scenario assumes a worsening of the economic environment caused by a prolonged Ukraine conflict, significant reduction in consumer demand due to inflationary pressures and a resurgence of Covid-19. This downside scenario results in a significant decline in second half sales of FY 2022/23, negative sales growth in FY 2023/24 and modest growth thereon in FY 2024/25. Additionally, operating margin was reduced, working capital materially increased, significant one-off expenditures included (product liability, major customer insolvency or litigation, climate change), interest rates increased significantly and an increase in the Group effective tax rate.

After factoring in the significant additional downsides, there remains good headroom both in terms of liquidity and our banking covenants. This is supported by the fact that the Group sells a wide portfolio of different products across a diverse set of industries and geographies, has low customer/supplier concentration, has a global supply chain network, diverse manufacturing capacity, and has well-established relationships with its customers. These factors are considered important in mitigating many of the risks that could affect the long-term viability of the Group. As a consequence, the Directors believe that the Group is well placed to manage its principal risks and uncertainties as disclosed on pages 54 to 59 of the Strategic Report.



### 2. Accounting policies continued

Reverse stress testing has also been applied to the most plausible downside scenario to determine the level of downside that would be required before the Group would be at risk of breaching its existing financial covenants or current liquidity headroom during the assessment period. The reverse stress test was conducted on the basis that certain mitigating actions would be undertaken to reduce overheads and capital expenditure during the period as sales declined and, on that basis, a fall in underlying operating margin to below 2% would be required before such a breach occurred. The Board considers the possibility of such a scenario to be remote and further mitigation, such as hiring freezes, pay and bonus reductions, headcount reductions, reduction in planned capital expenditure, suspension of dividend payments and equity raise, would be available if future trading conditions indicated that such an outcome were possible.

The Company acts as a holding company for investments in the subsidiaries and does not engage in any trading activities directly and thus is dependent on the trading activities of its subsidiaries. The Company holds sufficient net current assets as at 31 March 2022 to continue as a going concern.

The Directors are confident that the Company and the Group have sufficient resources to continue in operational existence for at least 12 months from the date of approval of the Financial Statements. Accordingly, they continue to adopt the going concern basis in preparing the Annual Report and Financial Statements.

### Basis of consolidation

The Group's consolidated Financial Statements consolidate the results of discoverIE Group plc and entities controlled by the Company (its subsidiaries).

The consolidated Financial statements comprise the financial statements of the Group and its subsidiaries for the year ended 31 March 2022. Subsidiaries are entities controlled by the Group. Control is achieved when the Group is exposed, or has rights, to variable returns from its involvement with the investee and has the ability to affect those returns through its control over it. In assessing control, the Group takes into account: (i) the power over the investee (i.e. existing rights that give it the current ability to direct its relevant activities); (ii) exposure, or rights, to variable returns from its involvement with the investee; and (iii) the ability to use its power over the investee to affect its returns.

The Group re-assesses whether or not it controls a subsidiary, if facts and circumstances indicate that there are changes to one or more of the three elements of control. Consolidation of a subsidiary begins when the Group obtains control and ceases when the Group loses control of the subsidiary. Assets, liabilities, profit and losses of a subsidiary acquired or disposed of during the year are included in the consolidated Financial Statements from the date control commences until the date control ceases.

When necessary, adjustments are made to the Financial Statements of subsidiaries to bring their accounting policies into line with the Group's accounting policies. All intra-group assets and liabilities, equity, income, expenses and cash flows relating to transactions between members of the Group are eliminated in full on consolidation.

### Prior year restatement

#### Discontinued Operations

The Group has restated the prior year comparatives in the consolidated Statement of Profit or Loss to exclude the results of discontinued operations with the objective of ensuring that the amounts disclosed for the year ended 31 March 2022 are comparable with the results for the year ended 31 March 2021 (the comparative period). Details of the financial position and results for the discontinued operations can be found in note 12 to the consolidated Financial Statements.

Following the disposal of the Group's Custom Supply Division, the Group has reviewed its reporting of operating performance to the Board, which is now organised into two new divisions: (i) Magnetics & Controls ("M&C") and (ii) Sensing & Connectivity ("S&C"). These have been assessed as the Reportable Operating Segments of the Group as described in note 5 to these Financial Statements.

**Financial Statements**

# NOTES TO THE GROUP FINANCIAL STATEMENTS

for the year ended 31 March 2022

**2. Accounting policies** continued

As a result, and according to requirements of IFRS 8 'Operating Segments', the Group has changed the disclosures in note 5 to reflect the new defined operating segments and has restated the corresponding items of segment information for last year.

**Presentation of the Consolidated Statement of Profit or Loss**

Following the discontinuance of the Custom Supply division, there is a broad range of gross margins within the operating companies of the Group which make operating profit margin a more consistent, reliable and comparable indicator of ongoing performance of the continuing operations. Accordingly, the Company has changed the presentation of the consolidated Statement of Profit and Loss for the year ending 31 March 2022 and the comparative prior year by amalgamating cost of sales, selling and distribution costs, and administrative expenses into one line item namely operating costs. There is no change to the prior year operating profit, profit before tax and profit for the year as a result of these presentational changes as demonstrated in the below table:

	2022 £m	2021 Restated* £m	2021 original £m
<b>Revenue</b>	<b>379.2</b>	<b>302.8</b>	454.3
Cost of Sales	<b>(233.0)</b>	<b>(187.7)</b>	(299.0)
<b>Gross profit</b>	<b>146.2</b>	<b>115.1</b>	155.3
Selling and distribution costs	<b>(37.7)</b>	<b>(32.3)</b>	(57.8)
Administrative expenses	<b>87.6</b>	<b>(65.7)</b>	(76.8)
<b>Operating profit</b>	<b>20.9</b>	<b>17.1</b>	20.7

\* Restated to exclude the results of discontinued operations as described in note 12 to the consolidated Financial Statements.

**FY 2021/22 Financial Statements (with changes in presentation)**

	2021 Restated £m
<b>Revenue</b>	302.8
Operating costs	(285.7)
<b>Operating profit</b>	17.1

**Configuration and Customisation costs in a Cloud Computing Arrangement**

The Group has changed its accounting policy relating to the capitalisation of certain software costs; this change follows the IFRIC Interpretation Committee's agenda decision published in April 2021 and relates to the capitalisation of costs of configuring or customising application software under 'Software as a Service' ('SaaS') arrangements. The Group's accounting policy has historically been to capitalise costs directly attributable to the configuration and customisation of SaaS arrangements as intangible assets in the consolidated Statement of Financial Position.

Following the adoption of the above IFRIC agenda guidance, the accounting policy was changed so that the Group only capitalises costs relating to the configuration and customisation of SaaS arrangements as intangible assets where control of the asset exists. As a result of this change in accounting policy, all current SaaS arrangements were identified and assessed to determine if the Group has control of the asset.

For those arrangements where the Group does not have control of the developed asset, the Group derecognised the intangible asset previously capitalised. The change in accounting policy led to adjustments amounting to a £0.4m reduction in intangible assets and a £0.4m reduction in retained earnings in the 31 March 2021 consolidated Statement of Financial Position. The 2021 consolidated Statement of Profit or Loss and Statement of Other Comprehensive Income have not been restated, as the impact on them is immaterial.

### 2. Accounting policies continued

Accordingly, the prior period consolidated Statement of Financial Position at 31 March 2021 have been restated in accordance with IAS 8 requirements. The overall impact of the adjustment is not considered to be material and, therefore, a consolidated Statement of Financial Position for 31 March 2020 has not been presented.

The tables below show the impact of the change in accounting policy on the previously reported financial position.

	As previously reported 2021 £m	Impact of restatement 2021 £m	Restated 2021 £m
Intangible asset – other	63.3	(0.4)	62.9
Retained earnings	48.4	(0.4)	48.0

### Underlying profits and earnings

These Financial Statements include alternative performance measures that are not prepared in accordance with IFRS. These alternative performance measures have been selected by management to assist them in making operating decisions as they represent the underlying operating performance of the Group and facilitate internal comparisons of performance over time. See note 6.

Alternative performance measures are presented in these Financial Statements as management believe they provide investors with a means of evaluating performance of the Group on a consistent basis, similar to the way in which management evaluates performance, that is not otherwise apparent on an IFRS basis, given that certain strategic non-recurring and acquisition related items that management does not believe are indicative of the underlying operating performance of the Group are included when preparing financial measures under IFRS. The trading results of acquired businesses are included in underlying performance.

The Directors consider there to be the following alternative performance measures:

#### Underlying operating profit

“Underlying operating profit” is defined as operating profit from continuing operations excluding acquisition related costs (namely amortisation of acquired intangible assets and acquisition expenses).

Acquisition expenses comprise transaction costs, contingent consideration relating to the retention of former owners of acquired businesses, adjustments to previously estimated contingent consideration, and costs related to integration of acquired businesses into the Group.

#### Underlying EBITDA

“Underlying EBITDA” is defined as underlying operating profit with depreciation, amortisation and equity settled share-based payment expense added back.

#### Underlying profit before tax

“Underlying profit before tax” is defined as profit before tax from continuing operations excluding acquisition related costs (namely amortisation of acquired intangible assets and acquisition expenses).

#### Underlying effective tax rate

“Underlying effective tax rate” is defined as the effective tax rate on underlying profit before tax.

#### Underlying earnings per share

“Underlying earnings per share” is calculated as underlying profit before tax reduced by the underlying effective tax rate, divided by the weighted average number of ordinary shares (for diluted earnings per share purposes) in issue during the year.

#### Operating cash flow

“Operating cash flow” is defined as underlying EBITDA adjusted for the investment in, or release of, working capital and less the cash cost of capital expenditure.

#### Free cash flow

“Free cash flow” is defined as net cash flow from continuing operations before dividend payments, net proceeds from equity fund raising, the cost of acquisitions and proceeds from business disposals.



## Financial Statements

# NOTES TO THE GROUP FINANCIAL STATEMENTS

for the year ended 31 March 2022

## 2. Accounting policies continued

### Return On Capital Employed ("ROCE")

"ROCE" is defined as underlying operating profit from continuing operations including the annualisation for acquisitions as a percentage of net assets excluding net debt, deferred consideration related to discontinued operations and legacy defined benefit pension asset/(liability).

### Investments (Company only)

Investments in subsidiary and associate undertakings are stated initially at cost, being the fair value of the consideration given and including directly attributable transaction costs. The carrying values are reviewed for impairment if events or changes in circumstances indicate the carrying values may not be recoverable.

### Non-current assets held for sale and discontinued operations

The Group reports a business as a discontinued operation when it has been disposed of in a period, or its future sale is considered to be highly probable at the balance sheet date, and results in the cessation of a major line of business or geographical area of operation. An asset or liability is classified as held for sale if it is available for immediate sale in its present condition subject only to terms that are usual and customary for sales of such assets and that it is highly probable the asset will be sold within one year from the date of classification. Non-current assets classified as held for sale and the assets of a disposal group classified as held for sale are presented separately from the other assets in the balance sheet. The liabilities of a disposal group classified as held for sale are presented separately from other liabilities in the balance sheet.

Discontinued operations are excluded from the results of continuing operations and are presented as a single amount as profit or loss after tax from discontinued operations in the Statement of Profit or Loss. Additional disclosures are provided in note 12. All other notes to the Financial Statements include amounts for continuing operations, unless otherwise mentioned.

### Business combinations and goodwill

Business combinations are accounted for using the acquisition method. The cost of an acquisition is measured as the aggregate of the consideration transferred, measured at acquisition date fair value and the amount of any non-controlling interest in the acquiree.

When the Group acquires a business, it assesses the financial assets acquired and liabilities assumed for appropriate classification and designation in accordance with the contractual terms, economic circumstances and relevant conditions at the acquisition date.

Any contingent consideration payable to the vendor will be recognised at fair value at the acquisition date. Subsequent changes to the fair value of the contingent consideration, which is deemed to be an asset or liability, will be recognised in accordance with IFRS 9 'Financial Instruments: Classification and measurement' either in the consolidated Statement of Profit or Loss or in Other Comprehensive Income.

Goodwill is initially measured at cost, being the excess of the aggregate of the acquisition-date fair value of the consideration transferred and the amount recognised for the non-controlling interest over the net identifiable amounts of the assets acquired and the liabilities assumed in exchange for the business combination. Assets acquired and liabilities assumed in transactions separate to the business combinations, such as the settlement of pre-existing relationships or post-acquisition remuneration arrangements, are accounted for separately from the business combination in accordance with their nature and applicable standard. Identifiable intangible assets, meeting either the contractual-legal or separability criterion are recognised separately from goodwill. Contingent liabilities representing a present obligation are recognised if the acquisition-date fair value can be measured reliably.

After initial recognition, goodwill is measured at cost less any accumulated impairment losses. For the purpose of impairment testing, goodwill acquired in a business combination is, from the acquisition date, allocated to each of the Group's cash-generating units ("CGUs") that are expected to benefit from the business combination, irrespective of whether other assets or liabilities of the acquiree are assigned to those units. Each unit or group of units to which goodwill is allocated shall represent the lowest level within the entity at which the goodwill is monitored for internal management purposes and shall not be larger than a reportable operating segment.

**2. Accounting policies** continued

Where goodwill forms part of a CGU and part of the operation within that unit is disposed of, the goodwill associated with the disposed of operation is included in the carrying amount of the operation when determining the gain or loss on disposal of the operation. Goodwill disposed of in this circumstance is measured based on the relative values of the operation disposed of and the portion of the CGU retained.

**Intangible assets – Other**

Other intangible assets that are separately acquired by the Group are stated at cost less accumulated amortisation and impairment losses. Other intangible assets acquired through a business combination are recognised at fair value at the date of acquisition less accumulated amortisation and impairment losses from the date of acquisition. Amortisation is charged to the Statement of Profit or Loss within operating costs on a straight-line basis over the useful economic lives of the intangible assets. The estimated useful economic lives are as follows:

(a) Software (implementation costs of IT systems)	3 to 10 years
(b) Acquired intangible assets	
Customer and supplier relationships	5 to 10 years
Patents	Patent term
(c) Intangible assets – research and development	

Expenditure on research activities is recognised as an expense in the period in which it is incurred. An internally generated intangible asset arising from the Group's development activities is capitalised only if all of the following conditions are met: (a) an asset is created that can be identified; (b) it is probable that the asset created will generate future economic benefits; and (c) the development cost of the asset can be measured reliably. Internally generated intangible assets are amortised on a straight-line basis over their useful lives between 5 and 10 years and charged to the Statement of Profit or Loss.

The Group only capitalises costs relating to the configuration and customisation of SaaS arrangements as intangible assets where control of the asset exists. Costs that are paid to SaaS suppliers in advance of the service provided are recognised in prepayment and amortised over the service period.

All other development expenditure is written off in the accounting period in which it is incurred.

**Property, plant and equipment**

Items of owned property, plant and equipment are stated at cost less accumulated depreciation and impairment losses.

Cost consists of all those elements which are directly attributable to bringing the asset into working condition for its intended use. Where there has been an indication of impairment in value such that the recoverable amount of an asset falls below its net book value, provision is made for such impairment. Wherever possible, individual assets are tested for impairment. However, impairment can often be tested only for groups of assets because the Cash Flows upon which the calculation is based do not arise from the use of a single asset. In these cases, impairment is measured for the smallest group of assets (the cash generating unit) that produces a largely independent income stream.

The cost of property, plant and equipment is charged to the Statement of Profit or Loss on a straight-line basis over the assets estimated useful economic life, taking into account their estimated residual value. The principal annual rates of depreciation are:

Land and buildings	Freehold property	2% to 4% per annum
	Leasehold buildings	Shorter of lease term and useful life
	Land is not depreciated	
Leasehold improvements		10% to 20% per annum or over the life of the lease if shorter
Plant and equipment		5% to 33% per annum



Financial Statements

## NOTES TO THE GROUP FINANCIAL STATEMENTS

for the year ended 31 March 2022

### 2. Accounting policies continued

#### Impairment of non-financial assets

The carrying amounts of the Group's assets, other than inventories and deferred tax assets, are reviewed at each balance sheet date to determine whether there is any indication of impairment. If such an indication exists, the asset's recoverable amount is estimated. An impairment loss is recognised whenever the carrying amount of the asset or its cash generating unit exceeds its recoverable amount. Impairment losses are recognised in the Statement of Profit or Loss.

The recoverable amount of assets is the greater of their net selling price and value-in-use. In assessing value-in-use, the estimated future cashflows are discounted to their present value using a pre-tax discount rate that reflects current market assessments of the time value of money and the risks specific to the asset. For an asset that does not generate largely independent cash inflows, the recoverable amount is determined for the CGU to which the asset belongs. A CGU is the smallest identifiable group of assets that generate cash inflows that are largely independent of the cash inflows from other assets or group of assets.

When estimating the future cash flows for the value-in-use calculation, the Group includes projections of cash outflows including central costs that are necessarily incurred to generate the cash inflows and that can be directly attributed or allocated on a reasonable and consistent basis to each CGU.

Impairment losses recognised in respect of CGUs are allocated first against the carrying value of any goodwill allocated to that unit, and then against the carrying values of other assets in the unit, on a pro rata basis.

An impairment loss in respect of goodwill is not reversed. In respect of other assets, an impairment loss is reversed when there is an indication that the impairment loss may no longer exist and there has been a change in the estimates used to determine the recoverable amount.

#### Financial Instruments

Financial assets and financial liabilities are initially recognised when the Group becomes a party to the contractual provisions of the instrument.

Unconditional receivables and payables are recognised as assets or liabilities when the entity becomes a party to the contract and, as a consequence, has a legal right to receive or a legal obligation to pay cash. However, recognition of financial assets to be acquired and financial liabilities to be incurred as a result of a firm commitment to purchase or sell goods or services, such as trade receivables and trade payables, is usually delayed until at least one of the parties has performed under the agreement and the ordered goods or services have been shipped, delivered or rendered.

A forward contract that is within the scope of IFRS 9, such as a forward foreign exchange contract, is recognised as an asset or a liability on the commitment date when the fair value of the right and obligation are usually equal and the net fair value of the forward contract on initial recognition is zero. If the net fair value of the right and obligation is not zero, the contract is recognised as an asset or liability.

Except for trade receivables without a significant financing component, a financial asset or a financial liability that is not measured through profit or loss (FVTPL) is initially measured at fair value plus or minus transaction costs that are directly attributable to its acquisition. A trade receivable without a significant financing component is initially measured at the transaction price.

The Group derecognises a financial asset when the contractual rights to the cash flows from the financial asset expire, or it transfers the rights to receive the contractual cash flows in a transaction in which substantially all of the risk and rewards of ownership of the financial asset are transferred or in which the Group neither transfers nor retains substantially all of the risks and rewards of ownership and it does not retain control of the financial asset.



### **2. Accounting policies** continued

The Group derecognises a financial liability when its contractual obligations are discharged or cancelled, or expire. The Group also derecognises a financial liability when its terms are modified and the cash flows of the modified liability are substantially different, in which case a new financial liability based on the modified terms is recognised at fair value. On derecognition of a financial liability, the difference between the carrying amount extinguished and the consideration paid is recognised in the Statement of Profit or Loss.

#### **Offsetting financial instruments**

Financial assets and liabilities are only offset and the net amount reported in the Statement of Financial Position when there is a legally enforceable right to offset and there is an intention to settle on a net basis or realise the asset and the liability simultaneously.

#### **Allowance for Expected Credit Losses**

The Group measures loss allowances for financial assets, including trade receivables, at an amount equal to lifetime expected credit losses (ECLs). This requires consideration of both historical and forward-looking information when considering potential impairment of trade receivables. A provision matrix is used to calculate the expected credit loss, which is based upon historical observed default rates adjusted for forward looking information to create an adjusted default rate, which is applied over the outstanding invoices at the balance sheet date.

Loss allowances for financial assets measured at amortised cost are deducted from the gross carrying amount of the assets.

#### **Credit-impaired financial assets**

At each reporting date the Group assesses whether financial assets carried at amortised cost are credit impaired. A financial asset is credit-impaired when one or more events that have a detrimental impact on the estimated future cash flows of the financial asset have occurred, such as a significant change in the credit risk profile of a customer, a debt has become significantly overdue or a contract default.

#### **Write-down of financial assets**

The gross carrying amount of a financial asset is written down to its recoverable amount when the Group has no reasonable expectations of recovering a financial asset in its entirety or a portion thereof.

#### **Derivative financial instruments**

The Group uses derivative financial instruments to hedge its exposure to foreign exchange risks arising from operational activities. It principally employs forward foreign exchange contracts to hedge the risks associated with foreign currency fluctuations relating to certain firm commitments and highly probable forecast transactions.

#### **Inventories**

Inventories comprise goods held for resale and work in progress and are stated at the lower of cost and net realisable value after making allowance for any obsolete or slow-moving items. Cost comprises direct materials, inward carriage and, where applicable, direct labour costs and those overheads that have been incurred in bringing the inventories to their present location and condition.

#### **Cash and cash equivalents**

Cash and cash equivalents in the consolidated Statement of Financial Position comprise cash balances and short-term deposits with an original maturity of three months or less. For the purpose of the consolidated Statement of Cash Flows, cash and cash equivalents comprise cash and cash equivalents as defined above, net of outstanding bank overdrafts.

#### **Borrowings**

Borrowings are recognised initially at fair value less directly attributable transaction costs. Subsequent to initial recognition, borrowings are stated at amortised cost with any difference between cost and redemption value being recognised in the Statement of Profit or Loss over the period of the borrowings on an effective interest basis.

**Financial Statements**

# NOTES TO THE GROUP FINANCIAL STATEMENTS

for the year ended 31 March 2022

**2. Accounting policies** continued

**Provisions**

A provision is recognised in the Statement of Financial Position when the Group has a present legal or constructive obligation as a result of a past event, and it is probable that an outflow of economic benefits will be required to settle the obligation. Where the effect is material, provisions are discounted to present value. The unwinding of the discount is recognised as a finance cost.

A provision for restructuring is recognised when the Group has approved a detailed and formal restructuring plan, and the restructuring has either commenced or has been publicly announced. Future operating costs are not provided for.

A provision for an onerous contract is recognised when the expected benefits to be derived by the Group from a contract are lower than the unavoidable cost of meeting its obligations under the contract.

**Leasing**

The Group assesses at contract inception whether a contract is, or contains, a lease. That is, if the contract conveys the right to control the use of an identified asset for a period of time in exchange for consideration. An asset can be identified either explicitly or implicitly. If implicitly, the asset is not mentioned in the contract, but the supplier can fulfil the contract only by the use of a particular asset, in which case there may be an identified asset. There is no identified asset if the supplier has a substantive right to substitute the asset.

**Separating components of a contract**

Contracts usually combine different kinds of obligation of the supplier, which may be formed by lease components or lease and non-lease components, such as maintenance/services. The Group identifies the lease and non-lease components and account for those separately, applying the relevant standard to each one. Consideration is allocated to each lease component on the basis of the relative stand-alone price of the lease component and the aggregate stand-alone price of the non-lease component.

**Combination of contracts**

Contracts are accounted together if they are entered into at or near the same time with the same counterparty and in contemplation of another.

**Lease term**

The lease term is the non-cancellable period of the lease plus periods covered by an option to extend or an option to terminate if the lessee is reasonably certain to exercise the extension option or not exercise the termination option.

**i) Right of use assets**

The Group recognises right of use assets at the commencement date of the lease. Right of use assets are measured at cost, less any accumulated depreciation and impairment losses, and adjusted for any remeasurement of lease liabilities. The cost of right of use assets includes the amount of lease liabilities recognised, initial direct costs incurred, and lease payments made at or before the commencement date less any lease incentives received.

Right of use assets are depreciated on a straight-line basis over the shorter of the lease term and the estimated useful lives of the assets.

If ownership of the leased asset transfers to the Group at the end of the lease term or the cost reflects the exercise of a purchase option, depreciation is calculated using the estimated useful life of the asset.

**ii) Lease liabilities**

At the commencement date of the lease, the Group recognises lease liabilities measured at the present value of lease payments to be made over the lease term. The lease payments include fixed payments (including in-substance fixed payments) less any lease incentives receivable, variable lease payments that depend on an index or a rate, and amounts expected to be paid under residual value guarantees.

### 2. Accounting policies continued

The lease payments also include the exercise price of a purchase option reasonably certain to be exercised by the Group and payments of penalties for terminating the lease, if the lease term reflects the Group exercising the option to terminate.

Variable lease payments that do not depend on an index or a rate are recognised as expenses (unless they are incurred to produce inventories) in the period in which the event or condition that triggers the payment occurs.

In calculating the present value of lease payments, the Group uses its incremental borrowing rate at the lease commencement date when the interest rate implicit in the lease is not readily determinable. The incremental borrowing rate is a combination of government bond yields, used as a proxy for a risk-free rate, calculated over various periods linked to existing lease terms. This rate is adjusted for borrowing costs and risks specific to each entity.

After the commencement date, the amount of lease liabilities is increased to reflect the accretion of interest and reduced for the lease payments made. In addition, the carrying amount of lease liabilities is remeasured if there is a modification, a change in the lease term, a change in the lease payments or a change in the assessment of an option to purchase the underlying asset.

Any adjustment of the lease liability is reflected as an adjustment to the right of use asset. If the carrying amount of the right of use asset has already been reduced to zero, the remaining remeasurement is recognised in profit or loss.

The Group has adopted the practical expedient under IFRS 16 not to recognise right of use assets and lease liabilities for short-term leases, with a lease term of 12 months or less and leases of low value. Lease payments relating to these leases are expensed to the Statement of Profit or Loss on a straight-line basis over the lease term.

#### Borrowing costs

Borrowing costs are recognised as an expense in the period in which they are incurred, in accordance with the effective interest rate method.

#### Pensions

Payments to defined contribution pension schemes are charged as an expense as they fall due.

In respect of defined benefit pension schemes, the position recognised in the consolidated Statement of Financial Position represents the present value of the defined benefit obligation, reduced by the fair value of the scheme assets.

Obligations to provide future benefit to employees earned through prior service are estimated and discounted to present value. Plan assets are measured at fair value. The cost of providing benefits under the defined benefit plans is determined by actuarial valuation, using the projected unit credit method.

Actuarial remeasurement of the net defined benefit liability or asset comprises (a) actuarial gains and losses, (b) the return on plan assets in excess of the amount included in net interest on the net defined benefit asset or liability, and (c) any change in the effect of the asset ceiling (where applicable), also excluding any amount included in net interest on the net defined benefit liability or asset; and is recognised immediately in the Statement of Financial Position with a corresponding entry in retained earnings through Other Comprehensive Income in the period in which it occurs. Remeasurement gains or losses are not reclassified to profit or loss in subsequent periods.

#### Share based payments

Employees of the Group receive remuneration in the form of share-based payments, whereby employees render services as a consideration for equity instruments (equity-settled transactions).

The cost of equity-settled transactions with employees is measured by reference to the fair value at the date the grant is made, calculated using an option pricing model, and is recognised as an expense over the vesting period, which ends on the date on which the relevant employees become fully entitled to the award. In valuing equity-settled transactions, no account is taken of non-market vesting conditions.



Financial Statements

## NOTES TO THE GROUP FINANCIAL STATEMENTS

for the year ended 31 March 2022

### 2. Accounting policies continued

At each reporting date before vesting, the cumulative expense is calculated, representing the extent to which the vesting period has expired and management's best estimate of the achievement or otherwise of non-market conditions and hence the number of equity instruments that will ultimately vest. The movement in cumulative expense since the previous reporting date is recognised in the consolidated Statement of Profit or Loss, with a corresponding entry in equity.

The issuance by the Company to its subsidiaries of a grant of options over the Company's shares represents additional capital contributions by the Company in its subsidiaries. The additional capital contribution is based on the fair value of the grant issued, allocated over the underlying grant's vesting period.

### Taxation

Current tax assets and liabilities are measured at the amount expected to be recovered from or paid to the taxation authorities, based on tax rates and laws that are enacted or substantively enacted by the reporting date. Management periodically evaluates positions taken in tax returns with respect to situations in which applicable tax regulation is subject to interpretation and considers whether it is probable that a taxation authority will accept an uncertain tax treatment. The group measures its tax balances either based on the most likely amount or the expected value, depending on which method provides a better prediction of the resolution of the uncertainty.

Deferred income tax is recognised on all temporary differences arising between the tax bases of assets and liabilities and their carrying amounts in the financial statements, with the following exceptions:

- where the temporary difference arises from the initial recognition of goodwill or of an asset or liability in a transaction that is not a business combination that at the time of the transaction affects neither accounting nor taxable profit or loss;
- in respect of taxable temporary differences associated with investments in subsidiaries and associates, where the timing of the reversal of the temporary differences can be controlled and it is probable that the temporary differences will not reverse in the foreseeable future; and
- deferred tax assets are recognised only to the extent that it is probable that taxable profit will be available against which the deductible temporary differences, carried forward tax credits or tax losses can be utilised.

Deferred tax assets and liabilities are measured on an undiscounted basis at the tax rates that are expected to apply when the related asset is realised or liability is settled, based on tax rates and laws enacted or substantively enacted at the reporting date.

Income tax is charged or credited directly to equity if it relates to items that are credited or charged to equity. Otherwise income tax is recognised in the consolidated Statement of Profit or Loss.

### Foreign currency translation

Transactions in foreign currencies are initially recorded in the functional currency at the exchange rate ruling at the date of the transaction. Monetary assets and liabilities denominated in foreign currencies are translated at the rate of exchange ruling at the reporting date and gains or losses on translation are included in the consolidated Statement of Profit or Loss.

Currency gains and losses arising from the retranslation of the opening net assets of foreign operations are recorded as a movement on reserves, net of tax. The differences that arise from translating the results of overseas businesses at average rates of exchange, and their assets and liabilities at closing rates, are dealt with in a separate currency translation reserve. All other currency gains and losses are dealt with in the consolidated Statement of Profit or Loss.



## 2. Accounting policies continued

### Revenue recognition

Revenue represents the fair value of the consideration received or receivable for goods, commission and other services provided to third parties, after deducting discounts, VAT and similar taxes levied overseas. Revenue is recognised in a way that depicts the transfer of promised goods or services to customers in an amount that reflects the consideration to which the Group expects to be entitled in exchange for those goods or services. Transaction price is allocated to each performance obligation on the basis of the relative stand-alone selling prices of each distinct good or service promised in the contract. If a stand-alone selling price is not observable, the Group estimates it. The transaction price may include a discount or a variable amount of consideration that relates entirely to a part of the contract. The Group will review the requirements and specify when the variable amount should be allocated to one or more, but not all, performance obligations in the contract.

Step 1: Identify the contract with a customer

Step 2: Identify the performance obligations in the contract

Step 3: Determine the transaction price

Step 4: Allocate the transaction price to the performance obligations in the contract

Step 5: Recognise revenue when (or as) the Group satisfies a performance obligation

Control of a good or service is obtained when the customer has the ability to direct the use of and obtain substantially all the benefits from the good or service.

The Group realises revenue from its principal activities through the sale of highly differentiated electronic products on four target markets: renewable energy, transportation, medical and industrial & connectivity.

The following are the Group's main revenue streams and criteria for control transfer:

#### a. Revenue from the sale of products

The Group recognises revenue from product sales at a point in time when the goods are delivered to, or accepted by the customer, if later, and control over the goods is transferred.

To determine the point in time at which the control is transferred to the customer, the Group considers whether or not:

- a. The Group has a present right to payment for the asset;
- b. The customer has acquired legal title to the asset;
- c. The Group has transferred physical possession of the asset;
- d. The customer has significant risks and rewards related to the ownership of the asset; and
- e. The customer has accepted the asset.

When another party is involved in providing goods or services to the customer, the Group determines whether the nature of its promise is a performance obligation to provide the specified goods or services itself (principal) or to arrange for those goods or services to be provided by the other party (agent) and recognises revenue accordingly.

#### b. Revenue from rendering of services

Product support and maintenance services are recognised over the period of the service delivery as the customer receives the benefit of the service over time. Progress is measured by reference to service periods.

Discounts are allocated proportionately to all performance obligations in the contract, unless the Group can demonstrate that the discount relates to one or more specific performance obligations.

### Contract balances

#### Receivables

Receivables billed under the terms of the contract for delivered goods and services and are not conditional on anything other than the passage of time. These assets are classified as Trade Receivables.



Financial Statements

## NOTES TO THE GROUP FINANCIAL STATEMENTS

for the year ended 31 March 2022

### 2. Accounting policies continued

#### Contract liabilities

The Group's unsatisfied obligation(s) for the transfer of goods or services to the customer for which consideration has been received from the customer or/and payments received in advance from a customer in consideration of future performance obligations.

#### Segment reporting

Operating segments are reported in a manner consistent with internal reporting provided to the chief operating decision maker. The chief operating decision maker, who is responsible for allocating resources and assessing performance of the operating segments, has been identified as the Board.

#### Dividend paid

Dividends are recognised when they meet the criteria for recognition as a liability. In relation to final dividends, this is when the dividend is approved by the shareholders in the general meeting, and in relation to interim dividends, when paid.

#### Dividend income

Dividend income is recognised in the Statement of Profit or Loss on the date the Group's right to receive payment is established.

#### Significant accounting judgements and estimates

The preparation of Financial Statements in conformity with IFRS requires management to make judgements, estimates and assumptions that affect the application of policies and reported amounts of assets and liabilities, income and expenses. The estimates and associated assumptions are based on historical experience and other applicable factors, the results of which form the basis of making the judgements about carrying values of assets and liabilities that are not readily apparent from other sources. The estimates and underlying assumptions are reviewed on an ongoing basis. Actual results may differ from these estimates and any revisions to estimates are recognised prospectively.

Information about judgements, assumptions and estimation uncertainties as at 31 March 2022 that could result in a material adjustment to the carrying amount of assets and liabilities in the next financial year is addressed regarding:

- **Impairment of non-financial assets (Group only):** Goodwill is tested annually for impairment, in accordance with IAS 36. An entity is required to ensure that its assets are not impaired and are carried at no more than their recoverable amount, measured based on the sum of future cash flows expected to be realised from sale or value-in-use. Assets which do not generate independent cash flows are required to be grouped together into CGU's and tested for impairment. In determining the recoverable amount of an asset or CGU, estimates and assumptions must be made in determining the value of those future cash flows. For a CGU this includes assessment of future revenue, operating profit, discount rates and long term growth rates. Uncertainty inherent in making judgements and estimates means that there is a risk that the estimated recoverable amount could result in a material adjustment in the future accounting period(s). Note 18 provides more details;
- **Measurement of defined benefit obligations (Group only):** The present value of the defined benefit obligations depends on a number of factors that are determined on an actuarial basis using a number of assumptions. The assumptions used in determining the net expense and balance sheet position include discount rates, inflation and mortality rates. Any changes in these assumptions will impact the carrying amount of defined benefit obligations. The actuarial assumptions used in determining the carrying amount at 31 March 2022 are set out in note 32;
- **Fair value of assets acquired in a business combination (Group only):** Estimates are made in assessment of fair value of the consideration and net assets acquired, including the identification and valuation of intangible assets and their useful lives. Estimates used include customer attrition rates, discount rate and trading forecast. Note 11 provides details on business combinations;

### 2. Accounting policies continued

- Value of investments (Company only):** Investments in subsidiaries are reviewed annually for impairment when indicators for impairment are identified. Determining whether the Company's investments in subsidiaries have been impaired requires estimations of the investments' values in use or consideration of the net asset value of the entity. The value-in-use calculations require the Directors to estimate the future cash flows, expected to arise from the investments, using estimates like future revenue, operating profit, discount rates and long term growth rates to calculate present values;

The following include information about judgements, assumptions and estimation uncertainties as at 31 March 2022 that are not considered significant and should not result in a material adjustment to the carrying amount of assets and liabilities in the next financial year:

- Recognition of deferred tax assets (Group only):** Judgement around the availability of future taxable profit against which tax deductible temporary differences and tax losses carried-forward can be utilised is necessary for the recognition of deferred tax assets;
- Estimating the incremental borrowing rate (Group only):** Where entities in the Group are required to recognise and measure a leasing liability, as lessee, lease payments should be discounted using the interest rate implicit in the lease, but often this cannot be readily determined from the leasing contract. Instead, the entity must determine its incremental borrowing rate, being the rate that the lessee would have to pay to borrow over a similar term, with a similar security, the funds necessary to obtain an asset of a similar value to the right of use asset, in a similar economic environment, considering factors such as the lessee's credit profile, borrowing currency and term of the lease. The process requires judgement in the determination of an appropriate rate;
- Inventories (Group only):** The carrying amounts of inventories are stated with due allowance for excess, obsolete or slow-moving items. The Directors exercise judgement in assessing net realisable value. Provisions for slow-moving and obsolete inventory are based on management's assessment of the nature and condition of the inventory, including assumptions around future demand and market conditions;

### 3. New accounting standards and financial reporting requirements

#### New standards applied

The Group has applied the following standards and amendments for the first time for its annual reporting period commencing 1 April 2021:

- IFRS 7 Financial Instruments: Disclosures – Amendment (replacement issues in the context of IBOR reform);
- IFRS 9 Financial Instruments – Amendment (replacement issues in the context of IBOR reform);
- IFRS 16 Leases – Amendment (replacement issue in the context of IBOR reform);
- IAS 39 Financial Instruments: Recognition and Measurement – Amendment (replacement issues in the context of the IBOR reform.
- IFRS 16 Leases – Amendment (Covid-19-related rent concessions)

These and other amendments, changes and improvements to IFRS issued by IASB have had no material impact on the Group and Company's current financial results or financial position.

#### New standards not yet applied

Certain new accounting standards and interpretations have been published that are not mandatory for 31 March 2022 reporting period and have not been early adopted by the Group. None of these are expected to have a material impact on the Group's financial results in the current or future reporting periods.

## Financial Statements

# NOTES TO THE GROUP FINANCIAL STATEMENTS

for the year ended 31 March 2022

## 4. Revenue

Group revenue is analysed below:

	2022 £m	2021 restated* £m
Sale of goods	370.0	293.5
Rendering of services	9.2	9.3
<b>Total revenue from continuing operations</b>	<b>379.2</b>	<b>302.8</b>

\* 2021 restated. Refer to note 2 to the consolidated Financial Statements.

## 5. Operating segment information

During the year, the Group completed the disposal of its Custom Supply Division, as described in note 12. As a result of the disposal, the Group has reorganised its businesses into two distinct divisions, Magnetics & Controls ("M&C") and Sensing & Connectivity ("S&C"). These have been assessed as the new Reportable Operating Segments in accordance with IFRS 8 'Operating Segments'. The senior management structure has also been aligned with these two segments.

Within each of the above reportable operating segment are aggregated business units with similar characteristics such as the nature of customers, products, risk profile and economic characteristics.

Management monitors the operating results of its business units separately for the purpose of making decisions about resource allocation and performance assessment. Segment performance is reported and evaluated based on operating profit or loss earned by each segment.

### Segment revenue and results

	Magnetics & Controls £m	Sensing & Connectivity £m	Unallocated Costs £m	Total continuing operations £m
<b>2022</b>				
<b>Revenue</b>	<b>234.7</b>	<b>144.5</b>	<b>-</b>	<b>379.2</b>
<b>Result</b>				
Underlying operating profit/(loss)	29.8	23.3	(11.7)	41.4
Acquisition expenses	(1.4)	(5.1)	-	(6.5)
Amortisation of acquired intangible assets	(4.8)	(9.2)	-	(14.0)
<b>Operating profit/(loss)</b>	<b>23.6</b>	<b>9.0</b>	<b>(11.7)</b>	<b>20.9</b>
<b>2021 (restated*)</b>				
<b>Revenue</b>	190.4	112.4	-	302.8
<b>Result</b>				
Underlying operating profit/(loss)	23.4	15.5	(8.1)	30.8
Acquisition expenses	0.4	(1.6)	-	(1.2)
Amortisation of acquired intangible assets	(3.5)	(7.6)	-	(11.1)
IAS 19 pension charge	-	-	(1.4)	(1.4)
<b>Operating profit/(loss)</b>	<b>20.3</b>	<b>6.3</b>	<b>(9.5)</b>	<b>17.1</b>

\* 2021 restated. Refer to note 2 to the consolidated Financial Statements.



## 5. Operating segment information continued Segment assets and liabilities

2022	Magnetics & Controls £m	Sensing & Connectivity £m	Total £m	
<b>Assets and liabilities</b>				
Segment assets (excluding goodwill and other intangible assets)	126.3	69.4	195.7	
Goodwill and other intangible assets	126.7	136.6	263.3	
	<b>253.0</b>	<b>206.0</b>	<b>459.0</b>	
Central assets			11.4	
Cash and cash equivalents			39.4	
Pension asset			2.7	
Current and deferred tax assets			10.8	
<b>Total assets</b>			<b>523.3</b>	
Segment liabilities	(77.5)	(41.9)	(119.4)	
Central liabilities			(15.1)	
Other financial liabilities			(69.6)	
Current and deferred tax liabilities			(28.8)	
<b>Total liabilities</b>			<b>(232.9)</b>	
<b>Net assets</b>			<b>290.4</b>	
2021	Magnetics & Controls £m	Sensing & Connectivity £m	Discontinued operations £m	Total £m
<b>Assets and liabilities</b>				
Segment assets (excluding goodwill and other intangible assets)	81.3	63.2	51.7	196.2
Goodwill and other intangible assets	65.1	114.6	10.2	189.9
	146.4	177.8	61.9	386.1
Central assets				3.2
Cash and cash equivalents				29.2
Current and deferred tax assets				9.7
<b>Total assets</b>				<b>428.2</b>
Segment liabilities	(45.0)	(33.7)	(36.3)	(115.0)
Central liabilities				(9.3)
Other financial liabilities				(76.4)
Pension liability				(1.0)
Current and deferred tax liabilities				(18.1)
<b>Total liabilities</b>				<b>(219.8)</b>
<b>Net assets</b>				<b>208.4</b>

For the purposes of monitoring segment performance and allocating resources between segments, the Directors monitor the net assets attributable to each segment. Assets and liabilities are allocated to reportable segments, with the exception of the pension liability, tax assets and liabilities, cash and all borrowings, central assets (Head Office assets) and central liabilities (Head Office liabilities).

## Financial Statements

# NOTES TO THE GROUP FINANCIAL STATEMENTS

for the year ended 31 March 2022

### 5. Operating segment information continued Other segment information

	Depreciation and amortisation <sup>1</sup>		Additions to non current assets <sup>1</sup>	
	2022 £m	2021 £m	2022 £m	2021 £m
Magnetics & Controls	10.8	8.9	76.1	1.9
Sensing & Connectivity	13.1	11.1	34.4	24.0
Central	0.3	0.4	0.8	1.7
	<b>24.2</b>	20.4	<b>111.3</b>	27.6

<sup>1</sup> Includes right of use assets, goodwill, acquired intangibles and related amortisation.

Magnetics & Controls additions comprised intangible assets £26.3m, goodwill £37.0m, right of use assets £9.3m and tangible assets £3.5m. Sensing & Connectivity additions comprised intangible assets £13.1m, goodwill £16.7m, right of use assets £3.3m and tangible assets £1.3m. Central additions comprised intangible assets £0.2m and tangible assets £0.6m.

### Geographical information

The Group's revenue from external customers based on customer locations and information about its segment assets (excluding pension asset) by geographical location are detailed below:

	Revenue from external customers		Non current assets	
	2022 £m	2021 restated* £m	2022 £m	2021 £m
UK	41.8	36.0	79.9	57.3
Europe	181.2	155.4	145.4	166.7
Rest of the World	156.2	111.4	98.9	21.0
	<b>379.2</b>	302.8	<b>324.2</b>	245.0

\* 2021 restated. Refer to note 2 to the consolidated Financial Statements.

### 6. Underlying profit before tax

	2022 £m	2021 restated* £m
Profit before tax	17.1	13.5
Add back Acquisition expenses		(a) 6.5
Amortisation of acquired intangible assets		(b) 14.0
Total IAS 19 pension charge		(c) -
Underlying profit before tax	<b>37.6</b>	27.2

\* 2021 restated. Refer to note 2 to the consolidated Financial Statements.

The tax impact of the underlying profit adjustments above is a credit of £2.0m (2021: £2.5m).

- a. Acquisition and merger related expenses of £6.5m comprise £2.6m of transaction costs in relation to the acquisition of CPI, Antenova, Beacon and ongoing transactions; £3.5m charge relating to the movement in fair value of contingent consideration and assets acquired on past acquisitions; and £0.4m charge in relation to the integration of acquired businesses in North America.



### 6. Underlying profit before tax continued

During the prior year there were £1.2m of acquisition and merger related expenses. £1.0m of transaction costs were incurred in relation to the acquisition of Phoenix, Limitor and ongoing transactions. There was a net contingent consideration credit of £0.2m in relation to current and past acquisitions and £0.4m charge in relation to the integration of acquired businesses in North America.

- b. Amortisation charge for intangible assets recognised on acquisition of £14.0m being amortisation of acquired customer relationships and patents. The equivalent charge last year was £11.1m. The increase relates to the five acquisitions during the last two years (Phoenix in October 2020, Limitor in February 2021, CPI in May 2021, Antenova in August 2021 and Beacon in September 2021).
- c. Pension costs in the prior periods related to a one-off adjustment relating to historic commutation terms for legacy scheme members.

### 7. Operating profit

Amounts charged/(credited) to the consolidated Statement of Profit or Loss are as follows

	2022	2021
	£m	restated* £m
Employee costs (note 8)	86.0	71.1
Depreciation of property, plant and equipment (note 15)	4.7	4.5
Depreciation of right of use assets (note 16)	5.1	4.0
Amortisation of other intangible assets (note 19)	14.9	11.7
Expected Credit Losses (note 21)	1.2	0.2
Net foreign exchange differences	(0.2)	(0.1)
Inventories:		
Cost of inventories	227.2	168.3
Write-down of inventories to net realisable value	2.6	1.7
Auditors' remuneration:		
Audit of the Group financial statements (including parent company)	0.6	0.4
Audit of local subsidiary financial statements	0.8	0.6

\* 2021 restated. Refer to note 2 to the consolidated Financial Statements.

The fee for non-audit services was £4k (2021: £8k). These mainly relate to reporting required by regulators in overseas countries.

### 8. Employee costs and Directors' emoluments

	2022	2021
	£m	restated* £m
Wages and salaries	70.6	58.5
Social security costs	10.3	8.5
Other pension costs	3.2	3.0
Share-based payments (note 31)	1.9	1.1
	86.0	71.1

\* 2021 restated. Refer to note 2 to the consolidated Financial Statements.



Financial Statements

## NOTES TO THE GROUP FINANCIAL STATEMENTS

for the year ended 31 March 2022

### 8. Employee costs and Directors' emoluments continued

The average monthly number of employees (including Executive Directors) during the year was as follows:

	2022	2021 restated*
Sales and marketing	264	262
Manufacturing and service	3,779	3,192
Administration	479	432
	<b>4,522</b>	<b>3,886</b>

\* 2021 restated. Refer to note 2 to the consolidated Financial Statements.

At 31 March 2022 the Group had 4,886 employees (2021: 4,024 restated).

	2022 £	2021 £
<b>Directors' emoluments</b>		
Aggregate emoluments in respect of qualifying services	1,980,849	1,271,111
Aggregate contribution to defined contribution scheme	94,671	79,230
	<b>2,075,520</b>	<b>1,350,341</b>

#### Highest paid director

Emoluments in respect of qualifying services	1,236,618	787,360
Pension contributions to the defined contribution scheme	73,514	61,523
	<b>1,310,132</b>	<b>848,883</b>

Retirement benefits are accruing to two Directors under a defined contribution pension scheme (2021: two).

Further details of Directors' emoluments are provided in the remuneration report on pages 109 to 132.

### 9. Finance income/(costs)

	2022 £m	2021 restated* £m
Interest receivable and similar income	0.4	0.3
<b>Finance income</b>	<b>0.4</b>	<b>0.3</b>
Finance costs on bank loans and overdrafts	(3.1)	(3.0)
Finance costs on lease liabilities	(0.6)	(0.4)
Amortisation of borrowing costs	(0.5)	(0.5)
<b>Finance costs</b>	<b>(4.2)</b>	<b>(3.9)</b>

\* 2021 restated. Refer to note 2 to the consolidated Financial Statements.



## 10. Tax expense

The major components of the corporation tax expense are summarised below:

	2022 £m	2021 restated* £m
<b>Current taxation:</b>		
UK corporation tax	(0.1)	–
UK adjustments in respect of prior years	0.2	–
	0.1	–
Overseas tax	8.6	6.7
Overseas adjustments in respect of prior years	0.1	–
	8.7	6.7
<b>Total current taxation expense</b>	<b>8.8</b>	<b>6.7</b>
<b>Deferred taxation</b>		
Origination and reversal of temporary differences within the UK	(1.3)	(1.1)
Origination and reversal of temporary differences overseas	(1.0)	(1.2)
Increased recognition of historic losses	0.2	(0.4)
Impact of tax rate changes	0.7	–
<b>Total deferred taxation credit</b>	<b>(1.4)</b>	<b>(2.7)</b>
<b>Tax expense reported in the consolidated Statement of Profit or Loss</b>	<b>7.4</b>	<b>4.0</b>
	2022	2021
<b>Tax recognised in other comprehensive expense</b>	<b>£m</b>	<b>£m</b>
(Decrease)/increase in deferred tax asset on pension	(0.5)	0.6
Tax reported in other comprehensive expense	(0.5)	0.6
	2022	2021
<b>Tax recognised in equity</b>	<b>£m</b>	<b>£m</b>
Increase in deferred tax asset on share based payments	1.5	1.3
Tax reported in equity	1.5	1.3

**Financial Statements**

# NOTES TO THE GROUP FINANCIAL STATEMENTS

for the year ended 31 March 2022

**10. Tax expense** continued

The effective rate of taxation for the year is higher (2021: higher) than the standard rate of taxation in the UK of 19% (2021: 19%). A reconciliation of the tax expense applicable to the profit before tax, at the statutory tax rate, to the actual tax expense at the Group's effective tax rate for the years ended 31 March 2022 and 31 March 2021 respectively is presented below:

	2022 £m	2021 restated* £m
Profit before tax	17.1	13.5
Profit before taxation multiplied by standard rate of corporation tax in the UK of 19% (2021: 19%)	3.2	2.6
<i>Effect of:</i>		
Different tax rates in overseas companies	1.5	1.0
Tax losses not recognised	0.3	–
Non-deductible expenses	1.1	0.8
Decreased/(increased) recognition of historic losses	0.2	(0.4)
Impact of tax rate changes on deferred tax	0.7	–
Adjustments to current taxation expense in respect of prior years	0.4	–
<b>Total tax reported in the consolidated Statement of Profit or Loss</b>	<b>7.4</b>	<b>4.0</b>
<b>Deferred tax</b>		
<i>Deferred tax liabilities</i>	<b>£m</b>	<b>£m</b>
Accelerated capital allowances	(0.8)	(0.3)
Intangibles	(18.3)	(11.1)
Pensions	(0.6)	–
Other temporary differences	(1.4)	(1.1)
<b>Gross deferred tax liabilities</b>	<b>(21.1)</b>	<b>(12.5)</b>
<i>Deferred tax assets</i>		
Decelerated capital allowances	–	0.2
Pensions	0.4	0.7
Tax losses	3.4	2.2
Share-based payment plans	3.8	3.5
Other temporary differences	1.6	1.3
<b>Gross deferred tax assets</b>	<b>9.2</b>	<b>7.9</b>

£2.6m of deferred tax assets and £3.6m of deferred tax liabilities are expected to be recovered or settled no more than twelve months after the reporting period. £6.6m of deferred tax assets and £17.5m of deferred tax liabilities are expected to be recovered or settled more than twelve months after the reporting period.



**10. Tax expense** continued

Movements in deferred tax	Accelerated capital allowances £m	Intangibles £m	Pensions £m	Tax losses £m	Share based payments £m	Other temporary differences £m	Total £m
<b>At 1 April 2020</b>	–	<b>(11.5)</b>	–	<b>2.2</b>	<b>2.2</b>	<b>(0.2)</b>	<b>(7.3)</b>
(Charged)/credited							
- to profit and loss*	(0.1)	2.1	0.1	–	–	0.4	2.5
- to other comprehensive income	–	–	0.6	–	–	–	0.6
- directly to equity	–	–	–	–	1.3	–	1.3
Discontinued operations*	–	–	–	–	–	(0.1)	(0.1)
Acquisition-related movements	–	(1.6)	–	–	–	–	(1.6)
<b>At 31 March 2021</b>	<b>(0.1)</b>	<b>(11.0)</b>	<b>0.7</b>	<b>2.2</b>	<b>3.5</b>	<b>0.1</b>	<b>(4.6)</b>
(Charged)/credited							
- to profit and loss	(0.5)	1.2	(0.3)	2.1	(1.2)	0.2	1.5
- to other comprehensive income	–	–	(0.5)	–	–	–	(0.5)
- directly to equity	–	–	–	–	1.5	–	1.5
Discontinued operations	(0.2)	–	(0.1)	(0.9)	–	(0.1)	(1.3)
Acquisition-related movements	–	(8.5)	–	–	–	–	(8.5)
<b>At 31 March 2022</b>	<b>(0.8)</b>	<b>(18.3)</b>	<b>(0.2)</b>	<b>3.4</b>	<b>3.8</b>	<b>0.2</b>	<b>(11.9)</b>

\* 2021 restated. Refer to note 2 to the consolidated Financial Statements.

At 31 March 2022, the Group had not recognised any deferred tax asset in respect of tax losses of approximately £23.1m (2021: £19.8m). Deferred tax assets are not recognised where there is insufficient evidence that losses will be utilised.

At 31 March 2022, a £0.6m deferred tax liability (2021: £0.5m) has been recognised for withholding taxes payable on the remittance of certain of the Group's overseas subsidiaries' unremitted earnings. The aggregate amount of unremitted earnings on which deferred tax has not been recognised is £18.9m (2021: £12.9m). No deferred tax has been recognised on this amount as the Group is able to control the timing of these distributions and is not expecting to distribute these profits in the foreseeable future.

An increase in the UK corporation tax rate to 25% had been substantively enacted at 31 March 2022, with effect from 1 April 2023. A rate of 19% will be applicable until the 25% rate becomes effective. Rates of 19% and 25% have been applied in the measurement of the Group's UK-based deferred tax assets and liabilities at 31 March 2022, based on an estimate of when the UK deferred tax is expected to crystallise.

**Financial Statements**

# NOTES TO THE GROUP FINANCIAL STATEMENTS

for the year ended 31 March 2022

**11. Business combinations**
**Acquisitions in the year ended 31 March 2022**
**Acquisition of CPI**

On 13 May 2021, the Group completed the acquisition of Control Products Inc ("CPI") via the purchase of 100% of the share capital and voting equity interests of Calculagraph Corporation, and which trades under the name of Control Products Inc ("CPI"). CPI, based in the USA, is a designer and manufacturer of custom, rugged sensors and switches.

CPI was acquired for an initial cash consideration of £8.9m (\$12.5m), before expenses, funded from the Group's existing debt facilities. In addition, a contingent payment of up to £3.8m (\$5.4m) will be payable subject to CPI achieving certain operational and profit growth targets during the four-year period ending 31 March 2025. £2.2m (\$3.2m) fair value of contingent consideration has been accounted for in the purchase price at the acquisition date.

The provisional fair value of the identifiable assets and liabilities of CPI at the date of acquisition were:

	<b>Provisional fair value recognised at acquisition £m</b>
Intangible assets – other (customer relationships)	4.4
Right of use assets	0.6
Inventories	0.9
Trade and other receivables	0.4
Net cash	0.6
Trade and other payables	(0.3)
Provisions	(0.1)
Lease liabilities	(0.6)
<b>Total identifiable net assets</b>	<b>5.9</b>
<b>Provisional goodwill arising on acquisition</b>	<b>5.2</b>
<b>Total investment</b>	<b>11.1</b>
<i>Discharged by</i>	
Initial cash consideration	8.9
Contingent consideration	2.2
	<b>11.1</b>
Net cash outflows in respect of the acquisition comprise:	
	<b>Total £m</b>
Fair value of cash consideration	8.9
Transaction costs of the acquisition (included in operating cash flows) <sup>1</sup>	0.5
Net cash acquired	(0.6)
	<b>8.8</b>

<sup>1</sup> Acquisition costs of £0.4m and £0.1m were expensed as incurred in the period ended 31 March 2022 and the year ended 31 March 2021 respectively. These were included within operating costs (note 6).

## II. Business combinations continued

Included in cash flow from investing activities is the cash consideration of £8.9m and the net cash acquired of £0.6m.

From the date of acquisition to 31 March 2022, CPI contributed £5.7m to revenue and £0.7m to profit after tax of the Group. If the business combination had taken place at the beginning of the year, the consolidated revenue for the Group would have been £379.7m and the consolidated profit after tax for the Group would have been £9.8m.

Included in the £5.2m of goodwill recognised above are certain intangible assets that cannot be individually separated and reliably measured from the acquiree, due to their nature. These include the value of expected operational benefits.

All the acquired receivables are expected to be collected.

### Acquisition of Antenova

On 25 August 2021, the Group completed the acquisition of 100% of the share capital and voting equity interests of Antenova Ltd ("Antenova"). Antenova, based in the UK, is a designer and manufacturer of antennas and radio frequency (RF) modules for industrial connectivity applications.

Antenova was acquired for a cash consideration of £20.9m, before expenses, funded from the Group's existing debt facilities.

The provisional fair value of the identifiable assets and liabilities of Antenova at the date of acquisition were:

	Provisional fair value recognised at acquisition £m
Property, plant and equipment	0.2
Intangible assets – other (customer relationships)	8.2
Intangible assets – other (software)	0.1
Right of use assets	0.3
Inventories	1.0
Trade and other receivables	0.9
Net cash	3.0
Trade and other payables	(1.2)
Current tax liabilities	(0.1)
Deferred tax liabilities	(1.9)
Lease liabilities	(0.3)
<b>Total identifiable net assets</b>	<b>10.2</b>
<b>Provisional goodwill arising on acquisition</b>	<b>10.7</b>
<b>Total investment</b>	<b>20.9</b>
<i>Discharged by</i>	
Cash	20.9
	<b>20.9</b>

**Financial Statements**

# NOTES TO THE GROUP FINANCIAL STATEMENTS

for the year ended 31 March 2022

**11. Business combinations** continued

Net cash outflows in respect of the acquisition comprise:

	<b>Total £m</b>
Fair value of cash consideration	20.9
Transaction costs of the acquisition (included in operating cash flows) <sup>1</sup>	0.6
Net cash acquired	(3.0)
	<b>18.5</b>

<sup>1</sup> Acquisition costs of £0.6m were expensed as incurred in the year ended 31 March 2022. These were included within operating costs (note 6).

Included in cash flow from investing activities is the cash consideration of £20.9m and the net cash acquired of £3.0m.

From the date of acquisition to 31 March 2022, Antenova contributed £4.8m to revenue and £0.3m to profit after tax of the Group. If the business combination had taken place at the beginning of the year, the consolidated revenue for the Group would have been £382.9m and the consolidated profit after tax for the Group would have been £10.2m.

Included in the £10.7m of goodwill recognised above are certain intangible assets that cannot be individually separated and reliably measured from the acquiree, due to their nature. These include the value of expected operational benefits.

All the acquired receivables are expected to be collected.

**Acquisition of Beacon**

On 2 September 2021, the Group completed the acquisition of Beacon EmbeddedWorks ("Beacon") via the purchase of 100% of the share capital and voting equity interests of Logic PD Inc which trades under the name of Beacon EmbeddedWorks. Based in the USA, Beacon is a designer, manufacturer and supplier of custom System on Module (SOM) embedded computing boards and related software, supplying the medical, industrial and aerospace & defence markets in the USA.

Beacon was acquired for a cash consideration of £57.7m (\$79.4m), before expenses, funded from the Group's existing debt facilities.



### II. Business combinations continued

The provisional fair value of the identifiable assets and liabilities of Beacon at the date of acquisition were:

	Provisional fair value recognised at acquisition £m
Property, plant and equipment	0.4
Intangible assets – other (customer relationships)	25.1
Right of use assets	2.2
Inventories	2.9
Trade and other receivables	1.9
Trade and other payables	(3.6)
Provisions	(0.2)
Deferred tax liabilities	(6.3)
Lease liabilities	(2.2)
<b>Total identifiable net assets</b>	<b>20.2</b>
<b>Provisional goodwill arising on acquisition</b>	<b>37.0</b>
<b>Total investment</b>	<b>57.2</b>
<i>Discharged by</i>	
Initial cash consideration	57.7
Working capital purchase price adjustment	(0.5)
	<b>57.2</b>
Net cash outflows in respect of the acquisition comprise:	
	<b>Total £m</b>
Fair value of cash consideration	57.7
Working capital purchase price adjustment	(0.5)
Transaction costs of the acquisition (included in operating cash flows) <sup>1</sup>	0.6
	<b>57.8</b>

<sup>1</sup> Acquisition costs of £0.9m were expensed as incurred in the period ended 31 March 2022. These were included within operating costs. £0.3m of costs remained unpaid at 31 March 2022 (note 6).

Included in cash flow from investing activities is the cash consideration of £57.7m.

From the date of acquisition to 31 March 2022, Beacon contributed £9.0m to revenue and loss of £1.3m to profit after tax of the Group. If the business combination had taken place at the beginning of the year, the consolidated revenue for the Group would have been £386.9m and the consolidated profit after tax for the Group would have been £10.3m.

Included in the £37.0m of goodwill recognised above are certain intangible assets that cannot be individually separated and reliably measured from the acquiree, due to their nature. These include the value of expected operational benefits.

All the acquired receivables are expected to be collected.

**Financial Statements**

# NOTES TO THE GROUP FINANCIAL STATEMENTS

for the year ended 31 March 2022

**11. Business combinations** *continued*
**Acquisitions in the year ended 31 March 2021**

There have been no changes to the provisional fair values of the assets and liabilities acquired in the prior year.

**Acquisition of Phoenix**

On 13 October 2020, the Group completed the acquisition of the trade and assets of Phoenix America Inc ("Phoenix"). The trade and assets were transferred to a newly incorporated company, Phoenix America LLC.

Phoenix was acquired for an initial cash consideration of £8.5m (\$10.9m) and funded from the Group's existing debt facilities. In addition, a contingent payment of up to £1.2m (\$1.5m) will be payable to the management shareholder subject to Phoenix achieving certain profit targets during the three-year period ended 31 December 2023. The fair value of the contingent consideration will be recognised in the consolidated Statement of Profit or Loss over the performance period.

Phoenix, based in the USA, is a designer and manufacturer of magnetically actuated sensors, encoders and related products for industrial customers.

The fair value of the identifiable assets and liabilities of Phoenix at the date of acquisition were:

	Fair value recognised at acquisition £m
Property, plant and equipment	0.5
Intangible assets – other	3.3
Inventories	0.7
Trade and other receivables	0.5
Trade and other payables	(0.2)
<b>Total identifiable net assets</b>	<b>4.8</b>
<b>Provisional goodwill arising on acquisition</b>	<b>3.7</b>
<b>Total investment</b>	<b>8.5</b>
<i>Discharged by</i>	
Cash	8.5
	<b>8.5</b>

Included in the £3.7m of goodwill recognised above are certain intangible assets that cannot be individually separated and reliably measured from the acquiree, due to their nature. These include the value of expected operational benefits.



### II. Business combinations continued

Net cash outflows in respect of the acquisition comprise:

	<b>Total £m</b>
Fair value of cash consideration	8.5
Transaction costs of the acquisition (included in operating cash flows) <sup>1</sup>	0.4
	<b>8.9</b>

<sup>1</sup> Acquisition costs of £0.1m and £0.3m were expensed as incurred in the years ended 31 March 2021 and 31 March 2020 respectively. These were included within operating costs (note 6).

Included in cash flow from investing activities is the cash consideration of £8.5m.

From the date of acquisition to 31 March 2021, Phoenix contributed £2.5m to revenue and £0.2m to profit after tax of the Group. If the business combination had taken place at the beginning of the year, the consolidated revenue for the Group would have been £305.0m and the consolidated profit after tax for the Group would have been £9.8m.

#### Acquisition of Limitor

On 11 February 2021, the Group completed the acquisition of the Limitor Group ("Limitor") via the purchase of 100% of the share capital and voting equity interests of Limitor GmbH and its subsidiary company Limitor Solutions GmbH and 100% of the share capital and voting equity interests of Limitor Hungaria Kft.

Limitor was acquired for an initial cash consideration of £12.8m (€14.6m), before expenses, funded from the Group's existing debt facilities. In addition, a contingent payment of up to £3.1m (€3.5m) will be payable subject to Limitor achieving certain operational and profit growth targets during the three-year period ended 31 March 2024. £0.4m of contingent consideration has been accounted for in the purchase price with the remaining fair value of the contingent consideration to be recognised in the consolidated Statement of Profit or Loss over the performance period.

Limitor, based in Germany and Hungary, designs and manufactures custom thermal safety components for industrial markets.

**Financial Statements**

# NOTES TO THE GROUP FINANCIAL STATEMENTS

for the year ended 31 March 2022

**11. Business combinations** continued

The fair value of the identifiable assets and liabilities of Limator at the date of acquisition were:

	Fair value recognised at acquisition £m
Property, plant and equipment	0.8
Intangible assets – other	6.5
Inventories	0.7
Trade and other receivables	0.9
Cash and cash equivalents	1.0
Trade and other payables	(0.8)
Current tax asset	0.1
Deferred tax liabilities	(1.6)
<b>Total identifiable net assets</b>	<b>7.6</b>
<b>Provisional goodwill arising on acquisition</b>	<b>6.2</b>
<b>Total investment</b>	<b>13.8</b>
<i>Discharged by</i>	
Initial cash consideration	12.8
Purchase price adjustment - settled in 2022	0.6
Contingent consideration	0.4
	<b>13.8</b>

Included in the £6.2m of goodwill recognised above are certain intangible assets that cannot be individually separated and reliably measured from the acquiree, due to their nature. These include the value of expected operational benefits.

Net cash outflows in respect of the acquisition comprise:

	Total £m
Fair value of cash consideration	12.8
Purchase price adjustment – settled in 2022	0.6
Transaction costs of the acquisition (included in operating cash flows) <sup>1</sup>	0.5
Net cash acquired	(1.0)
	<b>12.9</b>

<sup>1</sup> Acquisition costs of £0.5m were expensed as incurred in the year ended 31 March 2021 and were included within operating costs (note 6).

Included in cash flow from investing activities is the cash consideration of £12.8m and the net cash acquired of £1.0m.

From the date of acquisition to 31 March 2021, Limator contributed £1.3m to revenue and £0.2m to profit after tax of the Group. If the business combination had taken place at the beginning of the year, the consolidated profit after tax for the Group would have been £10.2m and the consolidated revenue for the Group would have been £309.7m.

The purchase price adjustment has changed the amount of Goodwill recognised for this acquisition.



### 12. Discontinued operations and assets held for sale

#### Disposals in the year ended 31 March 2022

During the year, the Group exited its distribution business by completing the disposal of its Acal BFi business and Vertec Scientific SA Proprietary Limited, which together has been referred to as the disposal group.

The disposal of the Acal BFi business completed on 3 March 2022 for an initial cash consideration of £37.6m net of normalised working capital adjustment and debt-like adjustments, and before expenses. In addition, deferred consideration (loan note) of £5m will be payable 3 years from completion of the disposal.

The disposal of Vertec Scientific SA Proprietary Limited completed on 5 January 2022 for an initial cash consideration of £1.3m, before expenses. In addition, deferred consideration of £0.9m will be payable over a 3-year period from completion.

The disposal group generated a profit on disposal of £6.6m, which is summarised below:

	<b>Total £m</b>
Net consideration	44.8
Net assets disposed of	(33.1)
Cumulative exchange loss reclassified from equity to the consolidated Statement of Profit or Loss	(2.0)
Transaction costs	(3.1)
<b>Profit on disposal</b>	<b>6.6</b>
Consideration received:	
Net upfront cash consideration received	38.9
Deferred consideration	5.9
<b>Net consideration receivable</b>	<b>44.8</b>
Net assets disposed of:	
Property, plant and equipment	1.4
Right of use assets	6.6
Intangible assets – Goodwill	9.4
Intangible assets – Other	1.0
Inventories	13.7
Trade and other receivables	34.8
Cash	1.6
Trade and other payables	(26.4)
Current tax liabilities	(1.4)
Lease liability	(5.9)
Provisions	(2.0)
Deferred tax assets	0.3
<b>Net assets disposed of</b>	<b>33.1</b>
Net cash inflow from disposal:	
Cash consideration	38.9
Cash disposed	(1.6)
Transaction costs of disposal (included in operating cash flows)	(2.4)
<b>Net cash inflow on disposal</b>	<b>34.9</b>

**Financial Statements**

# NOTES TO THE GROUP FINANCIAL STATEMENTS

for the year ended 31 March 2022

**12. Discontinued operations and assets held for sale** continued

The results of the disposal group are shown as discontinued operations for the year and the prior year and are presented below:

	2022 £m	2021 £m
Revenue	162.7	151.5
Operating costs	(150.3)	(147.9)
Operating profit	12.4	3.6
Finance costs	(0.2)	(0.1)
Profit before tax from operating activities	12.2	3.5
Tax expense	(2.9)	(1.0)
Profit for the year from operating activities	9.3	2.5
Gain on sale of discontinued operations	6.6	–
Tax expense on gain on sale of discontinued operations	(0.4)	–
Profit for the year from discontinued operations	15.5	2.5

**Earnings per share**

	2022 £m	2021 £m
Basic profit per share on discontinued operations	16.7p	2.8p
Diluted profit per share on discontinued operations	16.2p	2.7p

The operating profit for 2022 excludes £1.0m of depreciation charge on non-current assets as a result of them being classified as held for sale as at 30 September 2021.

Operating costs include £0.1m (2021: £0.2m) for auditors remuneration in relation to discontinued operations.

**Cash flows relating to trading activity of discontinued operations**

	2022 £m	2021 £m
Net cash inflow from operating activities	5.9	11.9
Net cash outflows from investing activities	(0.3)	(0.1)
Net cash outflows from financing activities	(2.1)	(2.3)
<b>Net increase in cash and cash equivalents</b>	<b>3.5</b>	<b>9.5</b>

**13. Dividends**

	2022 £m	2021 £m
<b>Dividends recognised in equity as distributions to equity holders in the year:</b>		
Equity dividends on ordinary shares:		
Final dividend for the year ended 31 March 2021 of 7.0p (2020: 0.0p)	6.2	–
Interim dividend for the year ended 31 March 2022 of 3.35p (2021: 3.15p)	3.2	2.8
<b>Total amounts recognised as equity distributions during the year</b>	<b>9.4</b>	<b>2.8</b>



### 13. Dividends continued

	2022 £m	2021 £m
<b>Proposed for approval at AGM:</b>		
Equity dividends on ordinary shares:		
Final dividend for the year ended 31 March 2022 of 7.45p (2021: 7.0p)	7.1	6.2
<b>Summary</b>		
Dividends per share declared in respect of the year	10.8p	10.15p
Dividends per share paid in the year	10.35p	3.15p
Dividends paid in the year	£9.4m	£2.8m

### 14. Earnings per share

Basic earnings per share is calculated by dividing the net profit for the year attributable to ordinary equity holders of the parent by the weighted average number of ordinary shares outstanding during the year.

Diluted earnings per share is the basic earnings per share after allowing for the dilutive effect of the conversion into ordinary shares of the weighted average number of options outstanding during the year.

The following reflects the income and share data used in the basic and diluted earnings per share computations:

	2022 £m	2021 £m
Profit for the year attributable to equity holders of the parent:		
Continuing operations	9.7	9.5
Discontinued operations	15.5	2.5
<b>Profit after tax for the year</b>	<b>25.2</b>	<b>12.0</b>
	<b>Number</b>	<b>Number</b>
Weighted average number of shares for basic earnings per share	93,015,684	88,753,576
Effect of dilution – share options	2,783,673	3,469,048
<b>Adjusted weighted average number of shares for diluted earnings per share</b>	<b>95,799,357</b>	<b>92,222,624</b>
Basic earnings per share from continuing operations	10.4p	10.7p
Diluted earnings per share from continuing operations	10.1p	10.3p
Basic earnings per share	27.1p	13.5p
Diluted earnings per share	26.3p	13.0p

Underlying earnings per share is calculated as follows:

	2022 £m	2021 £m
<b>Profit after tax for the year from continuing operations</b>	<b>9.7</b>	<b>9.5</b>
Acquisition expenses	6.5	1.2
Amortisation of acquired intangible assets	14.0	11.1
IAS 19 pension charge	–	1.4
Tax effect of the above	(2.0)	(2.5)
<b>Underlying profit after tax</b>	<b>28.2</b>	<b>20.7</b>

**Financial Statements**

# NOTES TO THE GROUP FINANCIAL STATEMENTS

for the year ended 31 March 2022

**14. Earnings per share** continued

	Number	Number
Weighted average number of shares for basic earnings per share	<b>93,015,684</b>	88,753,576
Effect of dilution – share options	<b>2,783,673</b>	3,469,048
<b>Adjusted weighted average number of shares for diluted earnings per share</b>	<b>95,799,357</b>	92,222,624
<b>Underlying earnings per share</b>	<b>29.4p</b>	22.4p

At the year end, there were 2,985,201 ordinary share options in issue that could potentially dilute underlying earnings per share in the future, of which 2,783,673 are currently dilutive (2021: 3,928,273 in issue and 3,469,048 dilutive).

**15. Property, plant and equipment**

	Land and buildings £m	Leasehold improvements £m	Plant and equipment £m	Total £m
<b>Cost</b>				
At 1 April 2020	11.4	4.0	32.8	48.2
Reclassification	0.3	(0.1)	(0.2)	–
Additions	–	0.3	2.9	3.2
Disposals	(0.3)	(0.1)	(0.5)	(0.9)
Arising from business combinations (note 11)	–	0.3	1.0	1.3
Exchange adjustments	(0.7)	–	(1.4)	(2.1)
At 31 March 2021	10.7	4.4	34.6	49.7
Additions	–	0.9	4.5	5.4
Disposals	–	–	(0.6)	(0.6)
Arising from business combinations (note 11)	0.1	–	0.6	0.7
Business disposed (note 12)	(2.0)	(1.6)	(2.4)	(6.0)
Exchange adjustments	–	0.2	0.3	0.5
<b>At 31 March 2022</b>	<b>8.8</b>	<b>3.9</b>	<b>37.0</b>	<b>49.7</b>
<b>Accumulated depreciation</b>				
At 1 April 2020	3.4	2.2	17.4	23.0
Reclassification	0.3	(0.1)	(0.2)	–
Charge for the year	0.4	0.4	4.1	4.9
Disposals	(0.1)	(0.1)	(0.4)	(0.6)
Exchange adjustments	(0.2)	(0.2)	(0.7)	(1.1)
At 31 March 2021	3.8	2.2	20.2	26.2
Charge for the year	0.4	0.4	3.9	4.7
Disposals	(0.1)	–	(0.4)	(0.5)
Business disposed (note 12)	(1.5)	(1.3)	(1.8)	(4.6)
Exchange adjustments	–	0.1	0.3	0.4
<b>At 31 March 2022</b>	<b>2.6</b>	<b>1.4</b>	<b>22.2</b>	<b>26.2</b>
<b>Net book value at 31 March 2022</b>	<b>6.2</b>	<b>2.5</b>	<b>14.8</b>	<b>23.5</b>
Net book value at 31 March 2021	6.9	2.2	14.4	23.5



### 15. Property, plant and equipment continued

Land and buildings includes land with a cost of £0.4m (2021: £0.8m) that is not subject to depreciation.

At 31 March 2022 the Group had non-contractual capital expenditure commitments for plant and equipment and leasehold improvements of £0.6m (2021: £1.1m) for which no provision has been made. The commitments are expected to be satisfied within one year of 31 March 2022.

### 16. Leases

#### 16.1 Leasing arrangements

The Group leases manufacturing and warehousing facilities, offices and various items of plant, machinery, equipment and vehicles.

Manufacturing and warehouse facilities generally have lease terms between 3 and 10 years. Lease contracts generally include extension and termination options and variable lease payments.

#### 16.2 Carrying value of right of use assets

Set out below are the carrying amounts of right of use assets recognised and movements during the year:

	Land and Buildings £m	Plant and machinery £m	Total £m
At 1 April 2020	18.7	2.4	21.1
Additions/modifications	6.7	1.7	8.4
Depreciation charge	(5.0)	(1.6)	(6.6)
Exchange adjustments	(0.5)	–	(0.5)
At 31 March 2021	19.9	2.5	22.4
Additions/modifications	8.8	1.0	9.8
Depreciation charge	(4.8)	(1.3)	(6.1)
Terminations	(0.5)	(0.2)	(0.7)
Business acquired (note 11)	1.9	1.2	3.1
Business disposed (note 12)	(5.5)	(1.1)	(6.6)
<b>At 31 March 2022</b>	<b>19.8</b>	<b>2.1</b>	<b>21.9</b>

**Financial Statements**

# NOTES TO THE GROUP FINANCIAL STATEMENTS

for the year ended 31 March 2022

**16. Leases continued**
**16.3 Carrying value of lease liabilities**

Set out below are the carrying amounts of lease liabilities and the movements during the year:

	<b>Total £m</b>
At 1 April 2020	(20.0)
Additions/modifications	(8.1)
Interest for the year	(0.6)
Lease payments	6.7
Exchange adjustments	0.5
At 31 March 2021	(21.5)
Additions/modifications	(9.3)
Interest for the year	(0.8)
Lease payments	7.2
Terminations	0.7
Business acquired (note 11)	(3.1)
Business disposed (note 12)	5.9
Exchange adjustments	(0.2)
<b>At 31 March 2022</b>	<b>(21.1)</b>

	<b>2022 £m</b>	2021 £m
Current liabilities	<b>4.7</b>	4.8
Non-current liabilities	<b>16.4</b>	16.7
	<b>21.1</b>	21.5

Payment of lease liabilities are shown under Financing Activities in the consolidated Statement of Cash Flows.

**16.4 Amounts recognised in the consolidated Statement of Profit or Loss\***

	<b>2022 £m</b>	2021 restated* £m
Depreciation of right of use assets	<b>5.1</b>	4.0
Interest expense (included in finance costs)	<b>0.6</b>	0.4
	<b>5.7</b>	4.4

\*The amounts presented above exclude discontinued operations.

**16.5 Extension and termination options**

Extension and termination options are included in a number of property and equipment leases across the Group. These terms are used to maximise operational flexibility in terms of managing contracts.

Variable lease payments based upon an index or rate are accounted for once rental amounts are changed.



### 17. Intangible assets – goodwill

<b>Cost</b>	<b>£m</b>
At 1 April 2020	154.1
Arising from business combinations	9.3
Exchange adjustments	1.3
At 31 March 2021	164.7
Arising from business combinations	53.7
Business disposed (note 11)	(46.2)
Exchange adjustments	3.5
<b>At 31 March 2022</b>	<b>175.7</b>
<b>Impairment</b>	<b>£m</b>
At 1 April 2020 and at 31 March 2021	(36.8)
Business disposed (note 12)	36.8
<b>At 31 March 2022</b>	<b>-</b>
<b>Net book value at 31 March 2022</b>	<b>175.7</b>
Net book value at 31 March 2021	127.9

### 18. Impairment testing of goodwill

Goodwill acquired through business combinations is allocated to cash-generating units ("CGUs") and tested annually for impairment. Newly acquired entities might be a single CGU until such time they can be integrated.

Following disposal of the Group's Custom Supply Division, as described in note 5, the Group's operations were reorganised into two distinct divisions, Magnetics & Controls ("M&C") and Sensing & Connectivity ("S&C"). Within each division are aggregated business units which generate largely independent cash inflows and are considered to be individual CGUs from an impairment testing perspective.

The carrying value of goodwill is analysed as follows:

	<b>2022</b>	<b>2021</b>
	<b>£m</b>	<b>£m</b>
Discontinued operations	-	9.6
Magnetics & Controls	<b>89.3</b>	49.5
Sensing & Connectivity	<b>86.4</b>	68.8
	<b>175.7</b>	127.9

The movement in goodwill compared to prior year relates to the movement in foreign exchange with the exception of Acal BFi, which was disposed of during the year (note 12) and CPI, Antenova and Beacon which were acquired in the year (note 11).

In the prior year, Noratel and Hobart businesses were integrated and therefore have been considered as one CGU for impairment testing. During the year the recently acquired businesses namely Positek, Phoenix, Limitor and CPI were integrated with the Variohm CGU. Prior to the integration, the individual businesses were tested for impairment to ensure that there was no impairment on a standalone basis.

**Financial Statements**

# NOTES TO THE GROUP FINANCIAL STATEMENTS

for the year ended 31 March 2022

**18. Impairment testing of goodwill** continued

The significant amounts of goodwill is analysed below:

	2022 £m	2021 £m
Noratel	<b>34.7</b>	33.6
Beacon	<b>38.8</b>	–
Variohm	<b>24.0</b>	17.6
Sens-Tech	<b>27.4</b>	27.4
	<b>124.9</b>	78.6

The Group defines significant as 10% of the total carrying value of goodwill.

The recoverable amount of each CGU is based on value-in-use calculations. The key assumptions used in these calculations relate to future revenue, operating margins, discount rates and long term growth rates. Cash flow forecasts for the five-year period from the reporting date are based on FY 2022/23 board approved budget and management projections thereon. Five-year Compound Annual Growth Rate (CAGR) for revenue between 3.6% and 11.8% (2021: between 1% and 8%) and operating margins between 7% and 45% (2021: between 5% and 50%) have been used depending on the size and sector in which the CGU operates. Cash Flow projections included in the impairment review models include management's view of the impact of climate change, including costs related to the effects of climate change, as well as the future costs of the Group's commitment to achieve a 50% reduction in carbon emissions in 2019 by 2025. The potential increased costs, less any benefits that may occur, to meet these commitments are not expected to be material and have therefore resulted in no impairments during 2022.

Long-term growth rate beyond the five-year period of 2% has been applied consistently across all CGUs (2021: 2%).

Discount rates reflect the current market assessment of the risks specific to each CGU. The discount rate was estimated based on the average percentage of a weighted average cost of capital for the industry and then further adjusted for size premium and country specific risk. The risk adjusted pre-tax discount rate applied to the cash flow projections of CGUs varies from 11% to 14% (2021: 13% to 15%).

The table below discloses the discount rates and short-term growth rates for each significant CGU:

	Pre-tax discount rate		5 year Sales CAGR	
	2022 %	2021 %	2022 %	2021 %
Noratel	<b>13.4</b>	14.0	<b>5.5</b>	5.2
Beacon	<b>11.7</b>	–	<b>11.8</b>	–
Variohm	<b>12.9</b>	12.9	<b>5.4</b>	8.7
Sens-Tech	<b>12.5</b>	13.1	<b>11.5</b>	14.3

The double-digit sales CAGR for Beacon and Sens-Tech reflects the recovery from the Covid-19 pandemic and ongoing supply chain disruptions.

**Sensitivity to changes in assumptions**

The Group's forecast is based on a range of assumptions to determine the value of expected future cash flows. Deviations against those plans and assumptions in terms of revenue and margin projections, operating and capital costs and successful achievement of strategic objectives are all inherently uncertain. Headroom in the impairment test for each CGU has been tested for sensitivity to adverse changes in forecast cash flows, discount rates and growth rate. Overall, adequate headroom is available against material impairment risk.



### 18. Intangible assets – goodwill continued

Management has identified one CGU within the Sensing & Connectivity division, which represents 3% of the total carrying amount of goodwill in the Group as at 31 March 2022, where changes in the value-in-use assumptions may lead to the recoverable amount of the CGU to be less than its carrying value. The assumptions made in estimating the value of the future cash flow are an LTGR of 2%, a pre-tax discount rate of 11% and a 5 Year Sales CAGR of 5%. The headroom for this CGU is £14.3m at the date of the assessment.

The Table below shows the reduction in headroom created by a change in assumptions:

	Reduction in headroom £m
Long-term growth rate – 1% decrease	3.0
Pre-tax discount rate – 1% increase	3.9
Sales CAGR – 2.4% decrease	8.8

None of the changes to individual assumptions above would lead to the carrying amount of the CGU exceeding its recoverable amount.

The assumptions that would result in the recoverable amount equalling the carrying amount are 5 years sales CAGR of 3% (a reduction of 2.4 percentage points), reduction in operating margin of 36%, long term growth rate of 1.5% (a reduction of 0.5 percentage points), and a pre-tax discount rate of 11.4% (an increase of 0.50 percentage points).

For all other CGUs it can be demonstrated that under reasonable downside sensitivity, there remains sufficient headroom in the recoverable amount of the CGU goodwill balances.



Financial Statements

## NOTES TO THE GROUP FINANCIAL STATEMENTS

for the year ended 31 March 2022

### 19. Intangible assets – other

	Acquired intangibles			Total £m
	Software & Development £m	Customer/ Supplier Relationships £m	Patents & Brands £m	
Cost				
At 1 April 2020	13.5	86.1	5.6	105.2
Prior year restatement (note 2)	(0.4)	–	–	(0.4)
At 1 April 2020 (restated*)	13.1	86.1	5.6	104.8
Arising from business combinations	–	9.9	–	9.9
Additions	0.6	–	–	0.6
Exchange adjustment	–	0.2	(0.1)	0.1
At 31 March 2021	13.7	96.2	5.5	115.4
Arising from business combinations	0.1	37.7	–	37.8
Additions	0.8	–	–	0.8
Disposals	(0.2)	–	–	(0.2)
Business disposed (note 12)	(9.2)	(3.8)	–	(13.0)
Exchange adjustment	–	2.3	–	2.3
<b>At 31 March 2022</b>	<b>5.2</b>	<b>132.4</b>	<b>5.5</b>	<b>143.1</b>
Accumulated amortisation				
At 1 April 2020	10.2	28.5	1.6	40.3
Charge for the year	0.6	10.6	0.5	11.7
Exchange adjustment	–	0.5	–	0.5
At 31 March 2021	10.8	39.6	2.1	52.5
Charge for the year	0.5	13.5	0.5	14.5
Business disposed (note 12)	(8.2)	(3.8)	–	(12.0)
Exchange adjustment	–	0.5	–	0.5
<b>At 31 March 2022</b>	<b>3.1</b>	<b>49.8</b>	<b>2.6</b>	<b>55.5</b>
<b>Net book value at 31 March 2022</b>	<b>2.1</b>	<b>82.6</b>	<b>2.9</b>	<b>87.6</b>
Net book value at 31 March 2021	2.9	56.6	3.4	62.9

\*2021 opening balance restated to reflect changes to Customisation and Configuration costs capitalised in Cloud Computing Arrangements (note 2).

### 20. Inventories

	2022 £m	2021 £m
Finished goods and goods for resale	<b>33.2</b>	34.2
Raw materials and work in progress	<b>44.6</b>	33.5
<b>Total inventories</b>	<b>77.8</b>	67.7

As at 31 March 2022, the provision for realisable value against total inventories was £6.9m (2021: £9.7m). £5.0m reduction in provision relates to the disposal of the Acal BFI business offset by £2.2m increase in provision for inventories in the continuing operations.



### 21. Trade and other receivables

<i>Current</i>	2022 £m	2021 £m
Trade receivables	63.8	75.5
Other receivables	11.2	6.8
Prepayments	3.0	2.6
	<b>78.0</b>	84.9

Trade receivables are non-interest bearing; are generally on 30 to 60 days' terms and are shown net of expected credit losses.

All of the Group's trade and other receivables are regularly reviewed for indicators of impairment. The credit risk exposure inherent in the Group's trade receivables is measured and recognised as an impairment provision on initial recognition, based on the Expected Credit Loss method, as required by IFRS 9. Specific provision for impairment may also be required where a specific increase in credit risk is identified, or a credit event has occurred. Provisions for general credit risk exposure is measured with reference to the age of a receivable as debts which are overdue present a specific impairment risk indicator regarding recoverability.

In total, the Group has recognised impairment provisions of £1.6m (2021: £1.2m), against trade receivables. This includes a total of £1.3m of specific provisions for impairment due to increased default risk and unresolved disputes, as well as provision for expected credit losses of £0.3m. Across the Group general expected credit loss risk has been assessed to be low due to the size, nature and diversification of customers across the divisions.

The movements in the impairment provisions for trade receivables during the year were as follows:

	2022 £m	2021 £m
At 1 April	1.2	1.1
Charge for the year	1.2	0.2
Amounts written off	–	(0.1)
Business disposals	(0.8)	–
At 31 March	1.6	1.2

Details of the net trade receivables ageing are set out below:

	Total £m	Not due £m	Overdue				
			<30 days £m	30–60 days £m	60–90 days £m	90–120 days £m	>120 days £m
<b>2022</b>	<b>63.8</b>	<b>56.1</b>	<b>6.7</b>	<b>0.7</b>	<b>0.2</b>	–	<b>0.1</b>
2021	75.5	64.8	7.8	1.1	0.4	0.4	1.0

#### *Non-Current*

	2022 £m	2021 £m
Other receivables	5.9	–

The other receivables amount of £5.9m (2021: nil) relates to deferred consideration receivable in relation to the disposal of the Acal BFi business and Vertec Scientific SA Proprietary Limited.



Financial Statements

## NOTES TO THE GROUP FINANCIAL STATEMENTS

for the year ended 31 March 2022

### 22. Cash and cash equivalents

	2022 £m	2021 £m
Cash at bank and in hand	<b>39.4</b>	29.2

Cash at bank earns interest at floating rates, based on daily bank deposit rates. The Group only deposits cash surpluses with major banks of high credit standing (£12.5m with HSBC; credit rating of AA-, £4.3m with Danske Bank; credit rating of A+, £2.4m with KBC Bank; credit rating of A+, £1.5m with Citibank; credit rating of A+, and the remaining balance of £18.7m with various financial institutions; credit rating of BBB- or higher) in line with its treasury policy. The fair value of cash and cash equivalents is £39.4m (2021: £29.2m).

### 23. Other financial liabilities

	Effective interest rate %	Maturity	Current		Non-current	
			2022 £m	2021 £m	2022 £m	2021 £m
Bank overdrafts	Variable	On demand	<b>2.5</b>	1.0	–	–
Unsecured bank loans	Variable		–	0.3	<b>2.3</b>	2.3
Revolving Credit Facility ("RCF")	Variable		–	–	<b>65.5</b>	74.0
Capitalised debt costs			<b>(0.5)</b>	(0.5)	<b>(0.2)</b>	(0.7)
Total other financial liabilities			<b>2.0</b>	0.8	<b>67.6</b>	75.6
Lease liabilities			<b>4.7</b>	4.8	<b>16.4</b>	16.7
Trade and other payables			<b>87.9</b>	79.3	<b>2.7</b>	0.8
<b>Total</b>			<b>94.6</b>	84.9	<b>86.7</b>	93.1

Interest on overdrafts is based on floating rates linked to SONIA.

Included in unsecured bank loans are USD-denominated loans of £2.2m (2021: £0.3m) carrying floating interest rates linked to LIBOR and Euro-denominated loans of £0.1m (2021: £0.1m) carrying fixed interest rates of 8%.

At 31 March 2022, the RCF drawdowns of £65.5m were denominated in Sterling, US Dollars and Euros which bear interest based on SONIA, SOFR and EURIBOR, plus a facility margin.

Trade and other payables above include only contractual obligations.

The maturity of the gross contractual financial liabilities is as follows:

	Within 1 year £m	2-5 years £m	>5 years £m	Total £m
<b>At 31 March 2022</b>				
Fixed and floating rate	<b>5.4</b>	<b>67.6</b>	–	<b>73.0</b>
Lease liabilities	<b>5.4</b>	<b>13.3</b>	<b>5.1</b>	<b>23.8</b>
Trade and other payables	<b>87.9</b>	<b>2.7</b>	–	<b>90.6</b>
	<b>98.7</b>	<b>83.6</b>	<b>5.1</b>	<b>187.4</b>



## Financial Statements

### 23. Other financial liabilities continued

At 31 March 2021	Within 1 year £m	2-5 years £m	>5 years £m	Total £m
Fixed and floating rate	0.8	75.6	–	76.4
Lease liabilities	5.5	11.1	7.6	24.2
Trade and other payables	79.3	0.8	–	80.1
	85.6	87.5	7.6	180.7

The carrying amount of the Group's other financial liabilities excluding lease liabilities is denominated in the following currencies:

	2022 £m	2021 £m
Sterling	45.3	40.5
Euro	38.2	68.2
US dollar	48.6	25.3
Other currencies	28.1	22.5
	160.2	156.5

### 24. Movements in cash and net debt

Year to 31 March 2022	1 April 2021 £m	Cash flow £m	Non cash changes £m	31 March 2022 £m
Cash and cash equivalents	29.2	9.0	1.2	39.4
Bank overdrafts	(1.0)	(1.4)	(0.1)	(2.5)
Net cash	28.2	7.6	1.1	36.9
Bank loans under one year	(0.3)	0.3	–	–
Bank loans over one year	(76.3)	7.9	0.6	(67.8)
Capitalised debt costs	1.2	–	(0.5)	0.7
Total loan capital	(75.4)	8.2	0.1	(67.1)
<b>Net debt</b>	<b>(47.2)</b>	<b>15.8</b>	<b>1.2</b>	<b>(30.2)</b>

Bank loans over one year above include £65.5m (2021: £74.0m) drawn down against the Group's revolving credit facility.

Year to 31 March 2021	1 April 2020 £m	Cash flow £m	Non cash changes £m	31 March 2021 £m
Cash and cash equivalents	36.8	(6.0)	(1.6)	29.2
Bank overdrafts	(2.0)	0.6	0.4	(1.0)
Net cash	34.8	(5.4)	(1.2)	28.2
Bank loans under one year	(2.8)	2.4	0.1	(0.3)
Bank loans over one year	(95.0)	16.1	2.6	(76.3)
Capitalised debt costs	1.7	–	(0.5)	1.2
Total loan capital	(96.1)	18.5	2.2	(75.4)
Net debt	(61.3)	13.1	1.0	(47.2)

Cash Flow movements for lease liabilities are shown in note 16.

**Financial Statements**

# NOTES TO THE GROUP FINANCIAL STATEMENTS

for the year ended 31 March 2022

**24. Movements in cash and net debt** continued  
 Supplementary information to the statement of cash flows

Underlying Performance Measure	2022 £m	2021 £m
Increase in net cash	15.8	13.1
Add: Business combinations	87.6	21.8
Dividends paid	9.4	2.8
Less: Net proceeds from share issue	(52.6)	(0.1)
Discontinued operations	(38.4)	(9.5)
<b>Free cash flow</b>	<b>21.8</b>	<b>28.1</b>
Net finance costs	3.2	3.1
Taxation	6.2	6.5
Legacy pension scheme funding	1.9	1.8
<b>Operating cash flow</b>	<b>33.1</b>	<b>39.5</b>

**25. Reconciliation of cash flows from operating activities**

	2022 £m	2021 £m
<b>Profit for the year</b>	<b>25.2</b>	<b>12.0</b>
Tax expense	10.7	5.0
Net finance costs	4.1	3.7
Depreciation of property, plant and equipment	4.7	4.9
Depreciation of right of use assets	6.1	6.6
Amortisation of intangible assets – other	14.5	11.7
Gain on business disposal	(6.6)	–
Gain on disposal of property, plant and equipment	(0.1)	–
Change in provisions	(0.3)	1.0
Pension scheme funding	(1.9)	(1.8)
IAS 19 pension charge	0.6	1.4
Impact of equity-settled share-based payment expense and associated taxes	1.3	1.1
<b>Operating cash flows before changes in working capital</b>	<b>58.3</b>	<b>45.6</b>
Increase in inventories	(17.7)	(0.1)
(Increase)/decrease in trade and other receivables	(24.9)	5.5
Increase in trade and other payables	26.8	6.2
(Decrease)/increase in working capital	(15.8)	11.6
<b>Cash generated from operations</b>	<b>42.5</b>	<b>57.2</b>
Interest paid	(3.7)	(3.4)
Interest paid on lease liabilities*	(0.8)	(0.6)
Income taxes paid	(7.1)	(7.2)
<b>Net cash flow from operating activities</b>	<b>30.9</b>	<b>46.0</b>

\*In the prior year Financial Statements, interest paid on lease liabilities were presented under Financing activities.



## Financial Statements

### 26. Provisions

	Severance and retirement indemnity £m	Other £m	Total £m
At 1 April 2020	3.3	2.3	5.6
Arising during the year	1.0	1.4	2.4
Utilised	(0.2)	–	(0.2)
Released	(0.2)	(0.2)	(0.4)
Exchange difference	(0.2)	–	(0.2)
At 31 March 2021	3.7	3.5	7.2
Arising during the year	0.4	1.6	2.0
Arising from business combinations	–	0.3	0.3
Business disposed (note 11)	(1.4)	(0.6)	(2.0)
Utilised	(0.2)	(0.9)	(1.1)
Released	(0.3)	(0.3)	(0.6)
Exchange difference	0.1	–	0.1
<b>At 31 March 2022</b>	<b>2.3</b>	<b>3.6</b>	<b>5.9</b>
		2022 £m	2021 £m
Analysis of total provisions:			
Current		<b>1.7</b>	1.8
Non-Current		<b>4.2</b>	5.4
		<b>5.9</b>	7.2

#### Severance and retirement indemnity

The severance provision relates to severance costs payable to employees.

Retirement indemnity provision of £2.2m (2021: £3.2m), relates to retirement and leaving indemnity schemes in Sri Lanka £0.9m, India £0.7m, Norway £0.3, France £0.2m and Germany £0.1m. The schemes are unfunded. The service cost, representing deferred salaries accruing to employees, is included as an operating expense and determined by reference to local laws and actuarial assumptions where applicable.

#### Other

Other provisions relates primarily to dilapidations provisions £2.1m (2021: £2.0m), warranty provisions £0.5m (2021: £0.6m), restructuring provisions of £0.1m (2021: £0.3m) and other provisions of £0.9m (2021: £0.6m). The provisions greater than one year are expected to be utilised within one to three years.

### 27. Financial risk controls

#### Management of financial risk

The main financial risks faced by the Group are credit risk, liquidity risk and market risk, which include interest rate risk and currency risk. The Board regularly reviews these risks and has approved written policies covering the use of financial instruments to manage these risks.

The Group Finance Director retains the overall responsibility and management of financial risk for the Group. Most of the Group's financing and interest rate and foreign currency risk management is carried out centrally at Group head office. The Board approves policies and procedures setting out permissible funding and hedging instruments, exposure limits and a system of authorities for the approval of transactions.

**Financial Statements**

# NOTES TO THE GROUP FINANCIAL STATEMENTS

for the year ended 31 March 2022

**27. Financial risk controls** *continued*
**Interest Rate Benchmark Reform – Phase 2**

As a result of the Interest Rate Benchmark Reform Phase 2, effective from periods beginning on or after 1 April 2021, the Group has assessed the impact of changes to the benchmark rates used required as a direct consequence of the IBOR Reform on its financial instruments.

The Group's has an overdraft facility that is based on floating rates linked to LIBOR. The facility agreement has been amended to reflect the changes required as a direct consequence of the IBOR reform. The agreement sets out the terms and conditions upon which the bank has agreed to make available to the Group a committed multi option facility. The interest on overdraft facilities is payable by the Group and is calculated by the bank, using its normal practices for calculation, each day.

Included in the unsecured bank loans are Euro-denominated loans and USD-denominated loans with fixed interest rates. These are not linked to a benchmark rate affected by the reform and, therefore, no changes were necessary.

The Group's RCF for drawdowns denominated in Sterling and USD which bear interest based on GBP LIBOR and USD LIBOR were amended to reflect the changes required by the IBOR reform. The interest charge is now calculated based on the risk free reference rate SONIA (sterling overnight index average) and the secured overnight financing rate (SOFR) administered by the Federal Reserve Bank of New York, respectively.

For the year ended 31 March 2022, the Group has applied the practical expedients provided under 'phase 2' amendments to its long-term debt recognised on the balance sheet in relation to its overdraft and RCF drawdowns, reflecting changes to base interest rates used for the calculation of interest recognised in the consolidated Statement of Profit or Loss of the Group. No impact from restatement was required as a consequence of these changes.

The Group has assessed the impact of the IBOR reform on other financial arrangements in place as at 31 March 2022 and concluded that there is no material impact on the Groups Financial Statements.

**Management of interest rate risk**

The Group has exposure to interest rate risk arising principally from changes in Euro, Sterling and US Dollar interest rates. The Group does not have any hedges in place at the year end against exposure to interest rate risk.

Based on the Group's debt position at the year end, excluding lease liabilities, a 1% increase in interest rates would decrease the Group's profit before tax by approximately £0.3m (2021: £0.5m).

**Management of foreign exchange risk**

The Group's shareholders' equity, earnings and cash flows are exposed to foreign exchange risks, due to the mismatch between the currencies in which it purchases stock and the final currency of sale to its customers.

It is Group policy to hedge identified significant foreign exchange exposure on its committed operating cash flows. This is carried out centrally based on forecast orders and sales.

The following table demonstrates the sensitivity of the Group's profit before tax to a 10% change in the rates of Sterling against all other currencies, US Dollar against all other currencies and Euro against all other currencies, with all other variables remaining constant due to changes in the fair value of monetary assets and liabilities.

	£ currency impact		US\$ currency impact		Euro currency impact	
	2022 £m	2021 £m	2022 £m	2021 £m	2022 £m	2021 £m
Profit before tax – gain/(loss)						
10% appreciation	<b>0.3</b>	0.2	<b>0.5</b>	1.1	–	(0.6)
10% depreciation	<b>(0.4)</b>	(0.3)	<b>(0.5)</b>	(1.1)	<b>0.1</b>	0.8



### **27. Financial risk controls** continued

#### **Management of credit risk**

Credit risk exists in relation to customers, banks and insurers. Exposure to credit risk is mitigated by maintaining credit control procedures across a wide customer base.

The Group is exposed to credit risk that is primarily attributable to its trade and other receivables. This is minimised by dealing with recognised creditworthy third parties who have been through a credit verification process. The maximum exposure to credit risk is limited to the carrying value of trade and other receivables.

As well as credit risk exposures inherent within the Group's outstanding receivables, the Group is exposed to counterparty credit risk arising from the placing of deposits and entering into derivative financial instrument contracts with banks and financial institutions. The Group manages exposure to this credit risk by entering into financial instrument contracts only with highly credit-rated authorised counterparties which are reviewed and approved annually by the Board.

Counterparties' positions are monitored on a regular basis to ensure that they are within the approved limits and that there are no significant concentrations of credit risks. The Group's largest customer is approximately 8% of Group sales.

#### **Management of liquidity risk**

The Group manages its exposure to liquidity risk and maximises its flexibility in meeting changing business needs through the cash generation of its operations, combined with bank borrowings and access to long-term debt. In its funding strategy, the Group's objective is to maintain a balance between the continuity of funding and flexibility through the use of overdrafts, bank loans and facilities.

At 31 March 2022, the Group had net cash of £36.9m (2021: £28.2m). The Group had total working capital facilities available of £200.2m (2021: £190.4m) with a number of major UK and overseas banks, of which £180.0m (2021: £180.0m) were committed facilities. The Group had drawn £70.3m against total facilities at 31 March 2022. In addition, the Group has a £60m accordion facility which it can use to extend the total facility up to £240m. The syndicated facility is available both for acquisitions and for working capital purposes. The facilities are subject to certain financial covenants, which had significant headroom at 31 March 2022.

On 3 May 2022, the Group increased its syndicated banking facility from £180m to £240m and extended the remaining term of the facility by two years out to four years ending in June 2026, with an option exercisable by the Group to extend the facility by a further year to June 2027. In addition, the Group has an £80m accordion facility which it can use to extend the total facility up to £320m.

#### **Management of capital**

The Group's objective when managing capital is to safeguard its ability to continue as a going concern and to maintain robust capital ratios to support the development of the business with a view to providing strong returns to shareholders. In order to maintain or adjust the capital structure, the Group increase bank borrowings, issue new shares or change the amount of dividends paid to shareholders. In respect to this objective, the Group has a target gearing range of between 1.5 and 2.0 times. Gearing at 31 March 2022 was below the range at 0.6 times.

The capital structure of the Group consists of debt, which includes the borrowings disclosed in note 23, cash and cash equivalent and equity attributable to shareholders.

**Financial Statements**

# NOTES TO THE GROUP FINANCIAL STATEMENTS

for the year ended 31 March 2022

**28. Financial assets and liabilities**
**Fair values**

The Group's principal non-derivative financial instruments comprise bank loans and overdrafts, cash and short term borrowings. The Group also holds other financial instruments such trade receivables and trade payables that arise directly from the Group's trading operations.

Derivative financial instruments are represented by short-term foreign currency forward contracts placed by the Group with external banks as part of the Group's cash management and foreign currency risk management activities. The fair value of derivative foreign exchange instruments is determined on initial recognition at forward market exchange rates at inception of the contract and subsequently remeasured based on forward market exchange rates at the balance sheet date. As at 31 March 2022, the fair value of derivatives was £nil (2021: £nil).

The carrying value of the Group's trade and other receivables and trade and other payables are disclosed in Notes 21 and 29. The carrying value of these items approximates book value due to the short maturity of these instruments. The carrying value of the Group's other financial assets and financial liabilities are set out below by category. Carrying values for all financial assets and liabilities are equivalent to fair values.

	Carrying amount 2022 £m	Fair value 2022 £m	Carrying amount 2021 £m	Fair value 2021 £m
<b>Financial assets</b>				
Cash at bank and in hand	39.4	39.4	29.2	29.2
<b>Financial liabilities at amortised cost</b>				
Bank overdrafts and short-term borrowings	(2.5)	(2.5)	(1.3)	(1.3)
Non-current interest-bearing loans and borrowings:				
Fixed and floating rate borrowings	(67.1)	(67.1)	(75.6)	(75.6)
Lease liabilities	(21.1)	(21.1)	(21.5)	(21.5)
Contingent consideration	(8.8)	(8.8)	(3.4)	(3.4)

The methods and assumptions used to determine the fair value of financial assets and liabilities are set out below. All material changes in fair value of financial instruments as at the balance sheet date have been taken to the Statement of Profit or Loss. Impairment reviews did not identify any material impairment of financial assets from carrying values as reported at the balance sheet date and, as such, no material impairments are included in the Statement of Profit or Loss.

**Fair Value Methods and Assumptions**

Forward foreign exchange contracts (forwards) - the fair value of forward foreign currency contracts is determined with reference to observable yield curves and foreign exchange rates at the reporting date. The FX contracts outstanding with banks at the year-end had a maturity of two years or less.

Loans and borrowings - the fair value of loans and borrowings has been calculated by discounting future cash flows, where material, at prevailing market interest rates.

**Fair Value Hierarchy**

For financial assets and financial liabilities measured at fair value, as set out in the tables above, the fair value measurement techniques are based upon applying unadjusted, quoted market rates or prices or inputs other than quoted prices that are observable for the assets or liability either directly or indirectly.

IFRS 13 'Financial Instruments: Disclosures' requires financial instruments measured at fair value to be analysed into a fair value hierarchy based upon the valuation technique used to determine fair value. The highest level in this hierarchy is Level 3 within which inputs that are not based on observable market data for the asset or liability are applied.

**28. Financial assets and liabilities** continued

The valuation techniques used by the Group for the measurement of derivative financial instruments and loans are considered to be within Level 2, which includes inputs other than quoted prices included within Level 1 that are observable either directly or indirectly.

**29. Trade and other payables**

<b>Current</b>	<b>2022</b> £m	2021 £m
Trade payables	<b>56.0</b>	56.8
Other payables	<b>33.8</b>	25.8
Accrued expenses and contract liabilities	<b>15.0</b>	12.2
	<b>104.8</b>	94.8

Trade payables are non-interest bearing and are settled in accordance with credit terms. Other payables are non-interest bearing and are settled throughout the year. Accrued expenses are non-interest bearing and are settled throughout the year. Included in current year other payables is contingent consideration of £4.0m which relates to the acquisition of Cursor Controls and £2.2m which relates to the acquisition of CPI. Prior year includes contingent consideration of £2.6m which related to the acquisition of Cursor Controls.

Contract liabilities relate to contracts with customers, recognised and measured in accordance with the requirements of IFRS 15, and relate to either advance payments received for goods to be delivered in the future or amounts invoiced in respect of performance obligations which are not yet satisfied in full and due to be satisfied within a period of 12 months from the reporting date.

Revenue recognised in the reporting period that was included in the contract liability balance at the beginning of the period amounted to £1.1m (2021: £0.9m).

Certain businesses in the Group participate in supply chain finance arrangements whereby suppliers may elect to receive early payment of their invoices from a bank by factoring their receivable from discoverIE entities. Included within trade payables is £0.9m (2021: £0.5m) subject to such an arrangement.

<b>Non-Current</b>	<b>2022</b> £m	2021 £m
Other payables	<b>2.7</b>	0.8

Included in non-current trade and other payable is a £2.7m contingent payment relating to the acquisitions of Limitor, Phoenix and CPI. For 2021, £0.8m related to the acquisitions of Sens-Tech, Limitor and Phoenix.

**30. Share capital**

<b>Allotted, called up and fully paid</b>	<b>2022</b> Number	<b>2022</b> £m	2021 Number	2021 £m
Ordinary shares of 5p each	<b>95,456,109</b>	<b>4.7</b>	89,455,915	4.4

During the year to March 2022, 650,000 shares were issued to the Group's Employee Benefit Trust (2021: 750,000). At 31 March 2022 the Trust held 168,425 shares (2021: 689,307). During the year to 31 March 2022, employees exercised 1,170,882 share options under the terms of the various share option schemes (2021: 60,693).

On 2 September 2021, 5,350,194 shares were issued for a gross consideration of £55.0m before costs and £53.5m after costs. The shares were issued at 1,028 pence per share, which is equal to the mid-market closing price on 2 September 2021. £0.3m was share capital with the balance of £53.2m being allocated to share premium account.

**Financial Statements**

# NOTES TO THE GROUP FINANCIAL STATEMENTS

for the year ended 31 March 2022

**31. Share-based payment plans**

The Group operates various share-based payment plans. The various schemes are explained below and have been separated into two separate disclosures. The charge to the consolidated Statement of Profit or Loss in respect of each of these schemes is:

	2022 £m	2021 £m
a) discoverIE Group plc long-term incentive plan ("the LTIP")	2.1	1.1
b) Approved and Unapproved Executive Share Option Schemes	–	–
	<b>2.1</b>	<b>1.1</b>

**a) The LTIP**

Since 2008, the Group has operated the LTIP as a replacement for the approved and unapproved executive share option scheme detailed above. The LTIP involves a conditional award of shares on a grant of a nil-cost option. The award of shares to Executive Directors and senior management is recommended by the Remuneration Committee on the basis of such factors as their contribution to the Group's success. The LTIPs are equity settled and there are no cash settled alternatives. The vesting of an award is dependent on the individual's continued employment for a three-year period from the date of grant and the satisfaction by the Company of certain performance conditions. The exercise of the awards is also subject to a two-year holding period from the date of vesting.

For awards made in 2022, the performance conditions are as follows:

- 50% of the award is based on the Company's comparative total shareholder return ("TSR") against a comparator group made up of the constituents of the FTSE Small Cap Index;
- 50% of the award is based on the Company's absolute earnings per share ("EPS") performance.
- For certain operational management, 25% of the award is based on the Company's absolute earnings per share ("EPS") performance and 75% of the award is based on local earnings targets.
- For two operational management, 100% of the award granted is subject to local earnings targets.

Awards are valued using the Monte Carlo Simulation and Discounted Share Price models. No non-market performance conditions were included in the fair value calculations. The fair value per award granted and the assumptions used in the calculation are as follows:

Awards granted in the year ended 31 March 2022:

Grant date	29 July 2021 TSR	29 July 2021 EPS	29 July 2021 EPS/Local	26 August 2021 Local
Share price at grant date	£10.4	£10.4	£10.4	£9.9
Exercise price	nil	nil	nil	nil
Number of employees	10	10	13	2
Shares under option	141,886	141,886	42,582	47,316
Vesting period (years)	3	3	3	3
Expected volatility	36.9%	36.9%	36.9%	n/a
Option life (years)	10	10	10	10
Expected life (years)	5	5	5	3
Risk-free rate of return	0.1%	0.1%	0.1%	n/a
Expected dividend yield	1.0%	1.0%	1.0%	1.0%
Fair value	£7.64	£9.25	£9.28	£9.60



### 31. Share-based payment plans continued

Awards granted in the year ended 31 March 2021:

Grant date	15 July 2020 EPS	30 June 2020 EPS	30 June 2020 TSR	30 June 2020 CPI
Share price at grant date	£5.90	£5.12	£5.12	£5.12
Exercise price	nil	nil	nil	nil
Number of employees	20	11	11	11
Shares under option	150,165	160,766	160,766	160,766
Vesting period (years)	3	3	3	3
Expected volatility	n/a	n/a	32.6%	32.6%
Option life (years)	10	10	10	10
Expected life (years)	5	5	5	5
Risk-free rate of return	n/a	n/a	-0.1%	-0.1%
Expected dividend yield	1.9%	1.9%	1.9%	1.9%
Fair value	£5.04	£4.38	£2.70	£2.37

The expected volatility is based on historical volatility over the period of time commensurate with the expected term immediately prior to the date of grant. The expected life is the average expected period to exercise. The risk-free rate of return used in the valuation is the rate of interest obtainable from government securities over a period commensurate with the expected term of the equity incentive.

The total charge for the year relating to the LTIP schemes was £2.1m (2021: £1.1m).

#### Outstanding LTIP

A summary of the awards that have been granted under the LTIP and remain outstanding is given below:

#### At 31 March 2022

Outstanding at 1 April 2021	Granted during the year	Forfeited during the year	Exercised during the year	Outstanding at 31 March 2022	Exercise dates
581,344	–	–	(581,344)	–	2020–2025
590,796	–	–	(516,729)	<b>74,067</b>	2021–2026
761,616	–	–	(28,269)	<b>733,347</b>	2022–2027
611,118	–	(131,283)	(14,040)	<b>465,795</b>	2023–2028
718,219	–	(5,404)	(8,185)	<b>704,630</b>	2024–2029
626,873	–	(37,703)	(3,884)	<b>585,286</b>	2025–2030
–	373,670	–	–	<b>373,670</b>	2026–2031
3,889,966	373,670	(174,390)	(1,152,451)	<b>2,936,795</b>	

**Financial Statements**

# NOTES TO THE GROUP FINANCIAL STATEMENTS

for the year ended 31 March 2022

**31. Share-based payment plans** continued  
**At 31 March 2021**

Outstanding at 1 April 2020	Granted during the year	Forfeited during the year	Exercised during the year	Outstanding at 31 March 2021	Exercise dates
615,574	–	–	(34,230)	581,344	2020–2025
590,796	–	–	–	590,796	2021–2026
761,616	–	–	–	761,616	2022–2027
611,118	–	–	–	611,118	2023–2028
727,062	–	(8,843)	–	718,219	2024–2029
–	632,463	(5,590)	–	626,873	2025–2030
3,306,166	632,463	(14,433)	(34,230)	3,889,966	

The weighted average remaining contractual life for the share options outstanding at 31 March 2022 is 6.8 years (2021: 6.6 years).

The range of exercise prices for options outstanding at the end of the year was nil (2021: nil).

**b) Approved and Unapproved Executive Share Option Schemes**

The Group operates an approved and an unapproved executive share option scheme, the rules of which are similar in all material respects. The grant of options to Executive Directors and senior management is recommended by the Remuneration Committee on the basis of their contribution to the Group's success. The options vest after three years.

The exercise price of the options is equal to the closing mid-market price of the shares on the trading day prior to the date of the grant. Exercise of all options is subject to continued employment. The life of each option granted is ten years. There are no cash settlement alternatives.

Options are valued using the binomial option-pricing model. No non-market performance conditions were included in the fair value calculations.

The fair value per option granted during the year and the assumptions used in the calculation are as follows:

Grant date	June 2021
Share price at grant date	£8.59
Exercise price	£8.03
Number of employees	8
Shares under option	13,665
Vesting period (years)	3
Expected volatility	33.9%
Option life (years)	10
Expected life (years)	6.5
Risk-free rate of return	0.5%
Expected dividends expressed as a dividend yield	1.2%
Fair value	£2.72

The expected volatility is based on historical volatility over the period of time commensurate with the expected term immediately prior to the date of grant. The expected life is the average expected period to exercise. The risk-free rate of return used in the valuation is the rate of interest obtainable from government securities over a period commensurate with the expected term of the equity incentive.

The total charge for the year relating to the approved and unapproved share option schemes was £nil (2021: £nil).



**31. Share-based payment plans** continued

**Outstanding share options**

A summary of the options over ordinary shares that have been granted under various Group share option schemes and remain outstanding is given below:

**At 31 March 2022**

Outstanding at 1 April 2021	Forfeited during the year	Exercised during the year	Granted during the year	Outstanding at 31 March 2022	Exercise price (pence)	Exercise dates
1,691	–	–	–	<b>1,691</b>	219.50	2020–2027
9,580	–	–	–	<b>9,580</b>	402.00	2021–2028
12,789	(116)	–	–	<b>12,673</b>	421.17	2022–2029
14,247	(1,516)	–	–	<b>12,731</b>	603.60	2023–2030
–	(1,934)	–	13,665	<b>11,731</b>	803.00	2024–2031
<b>38,307</b>	<b>(3,566)</b>	–	13,665	<b>48,406</b>		

**At 31 March 2021**

Outstanding at 1 April 2020	Forfeited during the year	Exercised during the year	Granted during the year	Outstanding at 31 March 2021	Exercise price (pence)	Exercise dates
26,853	–	(25,162)	–	1,691	219.50	2020–2027
9,580	–	–	–	9,580	402.00	2021–2028
12,789	–	–	–	12,789	421.17	2022–2029
–	–	–	14,247	14,247	603.60	2023–2030
<b>49,222</b>	–	<b>(25,162)</b>	14,247	<b>38,307</b>		

**Changes in share options**

A reconciliation of option movements over the year to 31 March 2022 is shown below:

	2022		2021	
	Number	Weighted average exercise price	Number	Weighted average exercise price
Outstanding at 1 April	<b>38,307</b>	<b>£4.75</b>	49,222	£3.07
Granted	<b>13,665</b>	<b>£6.04</b>	14,247	£6.04
Exercised	–	–	(25,162)	£2.20
Forfeited	<b>(3,566)</b>	<b>£7.06</b>	–	–
Outstanding at 31 March	<b>48,406</b>	<b>£5.51</b>	38,307	£4.75
Exercisable at 31 March	<b>11,271</b>	<b>£3.75</b>	11,271	£3.75

The weighted average remaining contractual life for the share options outstanding at 31 March 2022 is 7.7 years (2021: 8.2 years).

The range of exercise prices for options outstanding at the end of the year was £2.20 to £8.03 (2021: £2.20 to £6.04).

# NOTES TO THE GROUP FINANCIAL STATEMENTS

for the year ended 31 March 2022

## 32. Pension

### Defined contribution schemes

The Group makes payments to various defined contribution pension schemes, the assets of which are held in separately administered funds. In the United Kingdom, the relevant scheme is the discoverIE Group plc Employee Pension Scheme ('the discoverIE scheme'). Contributions by both employees and Group companies are held in externally invested trustee-administered funds.

The Group contributes a specified percentage of earnings for members of the discoverIE scheme, and thereafter has no further obligations in relation to the discoverIE scheme. At the year end, 190 employees were active members of the discoverIE scheme (2021: 190). The total cost charged to the consolidated Statement of Profit or Loss in relation to the UK-based discoverIE scheme was £362,000 (2021: £627,000). Employer contributions in respect of other UK-based schemes and overseas pension schemes were £447,000 (2021: £440,000) and £2,364,000 (2021: £2,598,000) respectively. The reductions in charges and contributions for the year related to the costs for the business disposed, which have been presented as discontinued operations in the Statement of Profit or Loss. Total contributions payable in the next financial year are expected to be at rates broadly similar to those in 2021/22 but based on actual salary levels in 2022/23.

### Defined benefit schemes

The acquisition of the Sedgemoor Group in June 1999 brought with it certain defined benefit pension schemes, together 'the Sedgemoor Scheme'. The Sedgemoor Scheme is funded by the Company, provides retirement benefits based on final pensionable salary and its assets are held in a separate trustee-administered fund.

Following the acquisition of the Sedgemoor Group, the Sedgemoor Scheme was closed to new members. Shortly thereafter, employees were given the opportunity to join the discoverIE scheme and future service benefits ceased to accrue to members under the Sedgemoor Scheme.

Contributions to the Sedgemoor Scheme are determined in accordance with the advice of independent, professionally qualified actuaries and are set based upon funding valuations carried out every three years.

Based upon the results of the triennial funding valuation at 31 March 2018, the Sedgemoor Scheme's Trustees agreed with Sedgemoor Limited on behalf of the participating employers to continue the same rate of participating employers' contributions under the deficit recovery plan agreed at the previous valuation at 31 March 2015. This required contributions of £1.8m over the year to 31 March 2020, with future contributions increasing by 3% each April payable over the period to 30 September 2022. These contributions are being reviewed as part of the triennial funding valuation as at 31 March 2021 which is currently in progress.

The estimated amount of employer contributions expected to be paid to the Sedgemoor Scheme during FY 2022/23 is £1.0m (FY 2021/22: £1.9m).

The results of the triennial funding valuation as at 31 March 2021 were updated to the accounting date by an independent qualified actuary in accordance with IAS 19.

The main actuarial assumptions used are set out as follows:

	2022	2021
Rate of increase of salaries	n/a	n/a
Rate of increase of pensions in payment	2.6%	2.5%
Discount rate	2.8%	1.9%
Inflation assumption – RPI	3.8%	3.4%
Inflation assumption – CPI*	2.7%	2.3%

\* 3.7% from 2031



### 32. Pension continued

The discount rate is based on the yields on AA grade Sterling corporate bonds at the reporting date.

Pensioner mortality assumptions are based on 110% of the 'S3NA' table, projected from 2013 and with long-term improvement rates in line with CMI 2021 core projections based on each member's actual date of birth with a long-term annual rate of improvement of 1.3% for males and for females.

The weighted average duration of the defined benefit obligation at 31 March 2022 was 12 years (2021: 13 years).

The investment strategy is set by the Trustee of the Sedgemoor Scheme in consultation with the Company. The current strategy is to invest 45% of the assets in equities, property, infrastructure and other return seeking investments and 55% in liability driven investments, corporate bonds and cash. As at 31 March 2022 the investment strategy hedged 75% of interest rate risk and 75% of inflation risk relative to the Sedgemoor Scheme's liability value for cash funding purposes.

As the Sedgemoor Scheme mostly invests in pooled funds, the fair value of assets reflect the fund managers' valuation rather than quoted prices in active markets, however, the fund values are all based on the prices of the underlying investments within each fund. Re-measurements are recognised immediately through other comprehensive income.

The charges recognised in the consolidated Statement of Profit or Loss in respect of defined benefit schemes are as follows:

	2022 £m	2021 £m
Pension charge (recognised in operating costs)	0.6	1.4

### Past Service cost

The charges recognised in the consolidated Statement of Comprehensive Income are as follows:

<b>Re-measurement gains/(losses):</b>	2022 £m	2021 £m
Return on plan assets (excluding amounts included in net interest expense)	0.3	0.6
Actuarial changes arising from changes in actuarial assumptions	2.0	(3.8)
Actuarial gain/(loss) recorded in the consolidated statement of comprehensive income	2.3	(3.2)

An additional actuarial loss of £0.1m (2021: £0.2m) relating to the unfunded retirement and leaving indemnity schemes (note 26) is recorded in the consolidated Statement of Comprehensive Income.

## Financial Statements

# NOTES TO THE GROUP FINANCIAL STATEMENTS

for the year ended 31 March 2022

### 32. Pension continued

The fair value of assets and expected rates of return used to determine the amounts recognised in the consolidated Statement of Financial Position are as follows:

	2022 £m	2021 £m
Equities	3.0	3.5
Bonds	9.4	9.9
Property	4.9	4.1
Diversified Growth Fund	5.8	6.6
Cash	0.4	4.4
Liability driven investments	5.0	5.6
Infrastructure	4.5	4.5
Asset Backed Security	6.0	–
Fair value of scheme assets	<b>39.0</b>	38.6
Present value of funded defined benefit obligations	<b>(36.3)</b>	(39.6)
<b>Asset/(liability) recognised in the consolidated Statement of Financial Position</b>	<b>2.7</b>	(1.0)

Changes in the present value of the defined benefit obligation are as follows:

	2022 £m	2021 £m
Opening defined benefit obligations	39.6	35.8
Net interest cost	0.7	0.9
Actuarial losses due to:		
Experience on benefit obligation	0.7	(0.1)
Changes in financial assumptions	(3.0)	3.9
Changes in demographic assumptions	0.3	–
Pension costs	–	1.0
Benefits paid	(2.0)	(1.9)
Closing defined benefit obligations	<b>36.3</b>	39.6

Changes in the fair value of the scheme assets are as follows:

	2022 £m	2021 £m
Opening fair value of scheme assets	38.6	37.6
Interest on scheme assets	0.8	0.9
Actual return on plan assets less interest on plan assets	0.3	0.6
Pension administration costs	(0.6)	(0.4)
Contributions	1.9	1.8
Benefits paid	(2.0)	(1.9)
Closing fair value of scheme assets	<b>39.0</b>	38.6

The prior year pension costs included £0.4m operating costs and a £1.0m charge relating to one-off adjustment relating to historic commutation terms for legacy scheme members.

**32. Pension** continued

**Sensitivities**

The sensitivity of the 2022 pension liabilities to changes in assumptions are as follows:

<b>Assumption</b>	<b>Change in assumption</b>	<b>Increase in scheme deficit £m</b>
Discount rate	Decrease by 0.5%	2.2
Inflation	Increase by 0.5%	0.7
Life expectancy	Increase by 1 year	1.9

**33. Related party disclosures**

As at 31 March 2022 the Group's subsidiaries are set out below. Unless otherwise stated, the Group holds (directly or indirectly) 100% of the total voting rights of all subsidiaries.

Except where noted, all material subsidiaries have a 31 March year end and the shares carry the same voting rights as their effective interest.

UK registered subsidiaries exempt from audit: discoverIE Nordic Holdings Limited (company no. 09056483); discoverIE Electronics Limited (06556285); Contour Holdings Limited (company no. 06846542); Variohm Holdings Limited (company no. 05783452); Xi-Tech Limited (company no. 07068708), Cursor Controls Holdings Limited (company no. 09472278), Positek Limited (company no. 02746707), Ixthus Instrumentation Limited (company no. 04876913) and Heason Technology Limited (company no. 06322037) qualify to take the statutory audit exemption as set out within section 479A of the Companies Act 2006 for the year ended 31 March 2022. discoverIE Group plc will guarantee the debts and liabilities of those companies at the statement of financial position date in accordance with section 479C of the Companies Act 2006.

<b>Name and nature of business</b>	<b>Registered address</b>	<b>Country of incorporation and registration</b>
<b>Management services - Head Office</b>		
discoverIE Management Services Limited	2 Chancellor Court, Occam Road, Surrey Research Park, Guildford GU2 7AH	England
<b>Operating companies</b>		
Antenova Limited	2 Chancellor Court, Occam Road, Surrey Research Park, Guildford GU2 7AH	England
Calculagraph Company (trading as Control Products Inc)	280 Ridgedale Avenue, East Hanover, New Jersey 07936	USA
Coil-Mag LLC (trading as IMAG Electronics)	160 South Illinois Street, Hobart, Indiana, 46342-4512	USA
Coil-Tran de Mexico SA de CV <sup>2</sup>	Calle Matamoros 124, Colonia Centro, Municipio Agualeguas, Nuevo Leon, CP 65800	Mexico
Coil-Tran LLC (trading as Hobart Electronics)	160 South Illinois Street, Hobart, Indiana, 46342-4512	USA
Contour Electronics Asia Limited	Room 601, 6/F Shing Yip Industrial Building, 19-21 Shing Yip Street, Kwun Teng, Kowloon	Hong Kong
Contour Electronics Limited	2 Chancellor Court, Occam Road, Surrey Research Park, Guildford GU2 7AH	England
Cursor Controls Limited	2 Chancellor Court, Occam Road, Surrey Research Park, Guildford GU2 7AH	England

**Financial Statements**

# NOTES TO THE GROUP FINANCIAL STATEMENTS

for the year ended 31 March 2022

**33. Related party disclosures** continued

Name and nature of business	Registered address	Country of incorporation and registration
Danselbud Noratel Transformator Sp Zoo	ul. Szczecinska 1K, Dobra Szczecinska PL-72-003	Poland
EMC Innovation Limited	Woolim Lions Valley C-409, 283 Bupyeong-daero, Bupyeong-gu, Cheongcheon-Dong, Incheon	South Korea
Flux A/S	Industrivangen 5, 4550 Asnaes	Denmark
Flux International Limited	41/27, 23 Village No. 6, Phuncaroen Lane, Bangna-Trad Km 16.5, Bang Chalong (Bangkok), Bang Phli District, Samut Prakan Province, 10540	Thailand
Foshan Noratel Electric Co Limited <sup>1</sup>	NO 22-2 Xingye Road, Zone C Shishan Science & Technology Industrial Park, Nanhai Distric, Foshan City, Guangdong Province 528225	China
Foss Fiberoptisk Systemsalg AS	Dansrudveien 45, N-3036 Drammen	Norway
Foss Fibre Optics s.r.o	Odborarska 52, 831 02 Bratislava	Slovakia
Heason Technology Limited	2 Chancellor Court, Occam Road, Surrey Research Park, Guildford GU2 7AH	England
Hectronic AB	P.O. Box 3002, 750 03 Uppsala	Sweden
Herga Technology Limited	2 Chancellor Court, Occam Road, Surrey Research Park, Guildford GU2 7AH	England
Limitor GmbH	Dieselstraße 22, 73660 Urbach	Germany
Limitor Hungaria Kft	Pécs, Makay István út 13/b, 7634	Hungary
Limitor Solutions GmbH	Dieselstraße 22, 73660 Urbach	Germany
Logic PD Inc (trading as Beacon Embedded Works)	6201 Bury Drive, Eden Prairie, MN 55346	USA
MTC Micro Tech Components GmbH	Hausener Straße 9, 89407 Dillingen a.d., Donau	Germany
Myrra Deutschland GmbH	Lebacher Straße 4, 66113 Saarbrücken	Germany
Myrra Hong Kong Limited	42/F Central Plaza, 18 Harbour Road, Wanchai	Hong Kong
Myrra Power Sp Zoo	Ul Warszawska 1, 05-310 Kaluszyn	Poland
Myrra SAS	2 Boulevard de La Haye, 77600 Bussy-Saint-Georges	France
Noratel AS	Elektroveien 7, 3300 Hokksund	Norway
Noratel Canada Incorporated	8-601 Magnetic Drive, Toronto, Ontario, M3J 3J2	Canada
Noratel Denmark A/S	Naverland 15, 2600 Glostrup, Copenhagen	Denmark
Noratel Finland OY	Kiertokatu 5, PB 11, 24280, Salo Helsinki	Finland
Noratel Germany AG	Elsenthal 53, DE-94481 Grafenau, Bremen	Germany
Noratel India Power Components Pvt Limited	Nila Technopark, Trivandrum, Kerala, 695581	India
Noratel International (Private) Limited	P.O Box 15, Phase 2 KEPZ, Katunayake	Sri Lanka
Noratel North America LLC	13663 Providence Road, Suite 345, Weddington, NC 28104	USA
Noratel Power Engineering LLC	1117 East Janis Street, Carson, CA 90746	USA
Noratel SP Z.o.o	ul. Szczecinska 1K, Dobra Szczecinska PL-72-003	Poland
Noratel Sweden AB	Lars Lindahlsväg 2, Bo Lars Lindahlsväg 2, Box 108, Laxå 69522	Sweden
Noratel UK Limited	2 Chancellor Court, Occam Road, Surrey Research Park, Guildford GU2 7AH	England



### 33. Related party disclosures continued

Name and nature of business	Registered address	Country of incorporation and registration
NSI bvba	Haakstraat 1A, 3740 Bilzen	Belgium
Phoenix America LLC	850 New Burton Road, Suite 201, Dover, DE 19904	USA
Positek Limited	2 Chancellor Court, Occam Road, Surrey Research Park, Guildford GU2 7AH	England
Santon Circuit Breaker Services B.V.	Hekendorpstraat 69, 3079 DX Rotterdam	Netherlands
Santon GmbH	Oberstrasse 1, Altes Rathaus Hinsbeck, Postfach 5217, 41334 Nettetal	Germany
Santon Group B.V.	Hekendorpstraat 69, 3079 DX Rotterdam	Netherlands
Santon Hekendorpstraat B.V.	Hekendorpstraat 69, 3079 DX Rotterdam	Netherlands
Santon Holland B.V.	Hekendorpstraat 69, 3079 DX Rotterdam	Netherlands
Santon International B.V.	Hekendorpstraat 69, 3079 DX Rotterdam	Netherlands
Santon Switchgear Limited	2 Chancellor Court, Occam Road, Surrey Research Park, Guildford GU2 7AH	England
Sens-Tech Limited	2 Chancellor Court, Occam Road, Surrey Research Park, Guildford GU2 7AH	England
Stortech Electronics Limited	2 Chancellor Court, Occam Road, Surrey Research Park, Guildford GU2 7AH	England
Variohm-Eurosensor Limited	2 Chancellor Court, Occam Road, Surrey Research Park, Guildford GU2 7AH	England
Vertec Scientific Limited	2 Chancellor Court, Occam Road, Surrey Research Park, Guildford GU2 7AH	England
Zhongshan Myrra Electronic Co Limited <sup>1</sup>	39-2 Industrial Road, Xiaolan Industrial Park, Xiaolan Town, 528400, Zhongshan, Guangdong Province	China
<b>Holding companies</b>		
Aramys SAS	2 Boulevard de La Haye, 77600 Bussy-Saint-Georges	France
Contour Holdings Limited	2 Chancellor Court, Occam Road, Surrey Research Park, Guildford GU2 7AH	England
Cursor Controls Holdings Limited	2 Chancellor Court, Occam Road, Surrey Research Park, Guildford GU2 7AH	England
discoverIE BV	Luchthavenweg 53, 5657 EA Eindhoven	Netherlands
discoverIE Electronics Limited	2 Chancellor Court, Occam Road, Surrey Research Park, Guildford GU2 7AH	England
discoverIE Europe Holding BV	Luchthavenweg 53, 5657 EA Eindhoven	Netherlands
discoverIE France Holdings SAS	4 Allée du Cantal – ZI Petite Montagne Sud – 91090 Lisses, Evry	France
discoverIE Holdings Limited	2 Chancellor Court, Occam Road, Surrey Research Park, Guildford GU2 7AH	England
discoverIE Nordic Holdings Limited	2 Chancellor Court, Occam Road, Surrey Research Park, Guildford GU2 7AH	England
DiscoverIE US Holdings Inc.	850 New Burton Road, Suite 201, Dover, DE 19904	USA
EWAC Holding B.V.	Hekendorpstraat 69, 3079 DX Rotterdam	Netherlands
Sedgemoor Limited	2 Chancellor Court, Occam Road, Surrey Research Park, Guildford GU2 7AH	England
Trafo Holding AS	Elektroveien 7, Hokksund, 3300	Norway



Financial Statements

## NOTES TO THE GROUP FINANCIAL STATEMENTS

for the year ended 31 March 2022

### 33. Related party disclosures continued

Name and nature of business	Registered address	Country of incorporation and registration
Variohm Holdings Limited	2 Chancellor Court, Occam Road, Surrey Research Park, Guildford GU2 7AH	England
Xi-Tech Limited	2 Chancellor Court, Occam Road, Surrey Research Park, Guildford GU2 7AH	England
<b>Dormant companies</b>		
Acal BFI Iberia SL	C/Anabel Segura, 7, Planta Acceso, 28108 Alcobendas, Madrid	Spain
Acal Electronics Limited	2 Chancellor Court, Occam Road, Surrey Research Park, Guildford GU2 7AH	England
Acal Supply Chain Limited	2 Chancellor Court, Occam Road, Surrey Research Park, Guildford GU2 7AH	England
Actech Holdings Limited	2 Chancellor Court, Occam Road, Surrey Research Park, Guildford GU2 7AH	England
Advanced Crystal Technology Limited	2 Chancellor Court, Occam Road, Surrey Research Park, Guildford GU2 7AH	England
Amega Electronics Limited	2 Chancellor Court, Occam Road, Surrey Research Park, Guildford GU2 7AH	England
Amega Group Limited	2 Chancellor Court, Occam Road, Surrey Research Park, Guildford GU2 7AH	England
BFI Optilas Denmark A/S	Jernabanegade 238, 4000 Roskilde Copenhagen	Denmark
BFI Optilas Limited	2 Chancellor Court, Occam Road, Surrey Research Park, Guildford GU2 7AH	England
Bosunmark Limited	2 Chancellor Court, Occam Road, Surrey Research Park, Guildford GU2 7AH	England
Cabcon (UK) Limited	2 Chancellor Court, Occam Road, Surrey Research Park, Guildford GU2 7AH	England
DiscoverIE North America LLC	850 New Burton Road, Suite 201, Dover, DE 19904	USA
Eurosensor Limited	2 Chancellor Court, Occam Road, Surrey Research Park, Guildford GU2 7AH	England
Gothic Crellon Limited	2 Chancellor Court, Occam Road, Surrey Research Park, Guildford GU2 7AH	England
Ixthus Instrumentation Limited	2 Chancellor Court, Occam Road, Surrey Research Park, Guildford GU2 7AH	England
Myrra Hispania Srl	c/Mataro 43 Pol. Ind. les Grases, 08980 Saint Feliu De Llobregat, Barcelona	Spain
Radiatron Components Limited	2 Chancellor Court, Occam Road, Surrey Research Park, Guildford GU2 7AH	England
Radiatron Holdings Limited	2 Chancellor Court, Occam Road, Surrey Research Park, Guildford GU2 7AH	England
Sedgemoor Group Pension Trustees Limited	2 Chancellor Court, Occam Road, Surrey Research Park, Guildford GU2 7AH	England
Sedgemoor Group Supplementary Pension Trustees Limited	2 Chancellor Court, Occam Road, Surrey Research Park, Guildford GU2 7AH	England
Sedgemoor Holdings Limited	2 Chancellor Court, Occam Road, Surrey Research Park, Guildford GU2 7AH	England
Townsend-Coates Limited	2 Chancellor Court, Occam Road, Surrey Research Park, Guildford GU2 7AH	England



### 33. Related party disclosures continued

<sup>1</sup> Zhongshan Myrra Electronic Co Limited and Foshan Noratel Electric Co Limited have 31 December year ends

<sup>2</sup> 15% of Coil-Tran de Mexico SA de CV is owned by local management

#### Related parties

##### Remuneration of key management personnel

The Group considers key management personnel as defined in IAS 24 'Related Party Disclosures' to be the members of the Group Executive Committee as set out on page 84. Remuneration is set out below in aggregate. The charge for share-based payments of £1.6m (2021: £0.7m) relates to the Group's LTIP as detailed in note 31.

	2022 £m	2021 £m
Short-term employee benefits	3.1	2.9
Pension benefits	0.2	0.2
Share-based payments	1.6	0.7
	<b>4.9</b>	<b>3.8</b>

##### Terms and conditions of transactions with related parties

All transactions with related parties were on an arm's length basis. Outstanding balances at year end are unsecured and settlement occurs in cash.

##### Transactions with other related parties

Details of transactions with Directors are detailed in the Remuneration report on pages 109 to 132.



## Financial Statements

# NOTES TO THE GROUP FINANCIAL STATEMENTS

for the year ended 31 March 2022

### 34. Exchange rates

The Statement of Profit or Loss of overseas subsidiaries are translated into sterling at average rates of exchange for the year and consolidated statements of Financial Position are translated at year end rates. The main currencies are the US Dollar, the Euro and the Norwegian Krone. Details of the exchange rates used are as follows:

	Year to 31 March 2022		Year to 31 March 2021	
	Closing rate	Average rate	Closing Rate	Average rate
US Dollar	1.3123	1.3668	1.3760	1.3075
Euro	1.1821	1.1761	1.1736	1.1207
Norwegian Krone	11.479	11.856	11.731	11.970

### 35. Events after the reporting date

There were no matters arising, between the Statement of Financial Position date and the date on which these financial statements were approved by the Board of Directors, requiring adjustment in accordance with IAS 10, Events after the reporting period. The following important non-adjusting events should be noted:

#### Dividends

A final dividend of 7.45p per share (2021: 7.0p), amounting to a dividend of £7.1m (2021: £6.2m) and bringing the total dividend for the year to 10.8p (2021: 10.15p), was declared by the Board on 14 June 2022. The discoverIE group Financial Statements do not reflect this dividend.

#### Revolving Credit Facility

On 3 May 2022, the Group increased its syndicated banking facility from £180m to £240m and extended the remaining term of the facility by two years out to four years ending in June 2026, with an option exercisable by the Group to extend the facility by a further year to June 2027. In addition, the Group has an £80m accordion facility which it can use to extend the total facility up to £320m.



## COMPANY STATEMENT OF FINANCIAL POSITION

as at 31 March 2022

	notes	2022 £m	2021 £m
<b>Non-current assets</b>			
Investments	5	203.4	201.3
		<b>203.4</b>	201.3
<b>Current assets</b>			
Debtors	6	81.3	29.9
Cash at bank and in hand		16.8	3.1
		<b>98.1</b>	33.0
<b>Total assets</b>		<b>301.5</b>	234.3
<b>Current liabilities</b>			
Creditors: amounts falling due within one year	7	(35.3)	(15.0)
		<b>(35.3)</b>	(15.0)
<b>Non-current liabilities</b>			
Other financial liabilities	8	–	(9.3)
		–	(9.3)
<b>Total liabilities</b>		<b>(35.3)</b>	(24.3)
<b>Net assets</b>		<b>266.2</b>	210.0
<b>Capital and reserves</b>			
Called up share capital	9	4.7	4.4
Share premium account		192.0	138.8
Merger reserve		10.5	19.9
Profit and loss account		59.0	46.9
<b>Total shareholders' funds</b>		<b>266.2</b>	210.0

The profit of the Company for the financial year ended 31 March 2022 was £10.2m (2021: £7.4m profit).

These financial statements on pages 213 to 217 were approved by the Board of Directors on 14 June 2022 and signed on its behalf by:

**Nick Jefferies**                      **Simon Gibbins**  
Group Chief Executive      Group Finance Director



Financial Statements

## COMPANY STATEMENT OF CHANGES IN EQUITY

for the year ended 31 March 2022

	Share capital £m	Share premium £m	Merger reserve £m	Profit and loss account £m	Total £m
<b>At 1 April 2020</b>	<b>4.4</b>	<b>138.8</b>	<b>22.7</b>	<b>38.4</b>	<b>204.3</b>
Profit for the year	-	-	-	7.4	7.4
Share-based payments	-	-	-	1.1	1.1
Transfer to profit or loss account	-	-	(2.8)	2.8	-
Dividends	-	-	-	(2.8)	(2.8)
<b>At 31 March 2021</b>	<b>4.4</b>	<b>138.8</b>	<b>19.9</b>	<b>46.9</b>	<b>210.0</b>
Profit for the year	-	-	-	10.2	10.2
Share-based payments	-	-	-	1.9	1.9
Shares issued (note 9)	0.3	53.2	-	-	53.5
Transfer to profit or loss account	-	-	(9.4)	9.4	-
Dividends	-	-	-	(9.4)	(9.4)
<b>At 31 March 2022</b>	<b>4.7</b>	<b>192.0</b>	<b>10.5</b>	<b>59.0</b>	<b>266.2</b>

At 31 March 2022, an amount of £40.2m out of the total £59.0m in the profit and loss account and £7.6m out of total £10.5m in the merger reserve is available for distribution, subject to filing these Financial Statements with Companies House. When making a distribution to shareholders, the Directors determine profits available for distribution by reference to guidance on realised and distributable profits under the Companies Act 2006 issued by the Institute of Chartered Accountants in England and Wales and the Institute of Chartered Accountants of Scotland in April 2017. The profits of the Company have been received in the form of dividends from subsidiary companies which have been paid to the Company in cash. The availability of distributable reserves in the Company is dependent on dividends received from subsidiary companies meeting the definition of qualifying consideration within the guidance referred to above, and on the available cash resources of the Group and other accessible sources of funds. The level of distributable reserves is subject to any future restrictions or limitations at the time such distribution is made.



# NOTES TO THE COMPANY FINANCIAL STATEMENTS

for the year ended 31 March 2022

## 1. Basis of preparation

The separate Financial Statements of the Company have been prepared for all periods presented, in accordance with Financial Reporting Standard 101 'Reduced Disclosure Framework' (FRS 101) and in accordance with the Companies Act 2006. These Financial Statements are prepared on the going concern basis and under the historical cost convention modified for fair values, as described in note 2 to the Group consolidated Financial Statements.

## 2. Summary of significant accounting policies

The summary of significant accounting policies for the Company is described in note 2 to the Group consolidated Financial Statements.

## 3. Profit of the company

The profit of the company for the financial year was £10.2m (2021: £7.4m profit). By virtue of section 408(3) of the Companies Act 2006, the Company is exempt from presenting a separate Statement of Profit or Loss.

## 4. Employees

The Directors also provide services to other group undertakings and received remuneration from a fellow group undertaking, discoverIE Management Services Limited in respect of services to the Group. Directors Emoluments are shown in note 8 to the consolidated Financial Statements.

## 5. Investments

	Subsidiary undertakings £m
At 1 April 2020	200.2
Share-based payments	1.1
At 31 March 2021	201.3
Share-based payments	2.1
<b>At 31 March 2022</b>	<b>203.4</b>

Details of all direct and indirect holdings in subsidiaries are provided in note 33 of the consolidated Financial Statements.

Equity investments in subsidiary undertakings are reviewed annually for indicators of impairment of the carrying value, measured at cost less accumulated impairment losses. Where the net assets of a subsidiary fall below the carrying amount of the investment an impairment test is performed. The impairment test compares the carrying amount to the estimated recoverable amount, calculated based on value in use of the forecast business cash flows, discounted at the Company's pre-tax discount rate.

The results of this review have not identified any further impairment of carrying value at the current reporting date of 31 March 2022 (2021: nil). In respect of one of the investments in subsidiaries undertakings with the carrying value of £18.5m, changes in the value-in-use assumptions may lead to the recoverable amount to be less than its carrying value. The assumptions made in estimating the value of the future cash flow are an LTGR of 2%, a pre-tax discount rate of 13.2% and a 5 Year Sales CAGR of 7%. A reduction in the long-term growth rate, pre-tax discount rate and 5-year sales CAGR of 1ppt would result in impairment of £1.5m, £2.0m and £1.7m respectively.



## Financial Statements

# NOTES TO THE COMPANY FINANCIAL STATEMENTS

for the year ended 31 March 2022

## 6. Debtors

	2022 £m	2021 £m
<b>Amounts falling due within one year:</b>		
Amounts owed by subsidiary undertakings	78.5	28.0
Corporation tax	1.9	1.7
Other debtors	0.8	0.1
Prepayments	0.1	0.1
	<b>81.3</b>	<b>29.9</b>

Amounts owed by subsidiary undertakings bore interest at a sterling base rate plus a margin of 1.75% and at USD one month LIBOR plus a margin of 2%. All amounts are repayable on demand. There are no material expected credit losses recognised for these receivables.

At 31 March 2022, the Company had not recognised any deferred tax asset in respect of tax losses of approximately £3.1m (2021: £2.1m). Deferred tax assets are not recognised where there is insufficient evidence that losses will be utilised.

## 7. Creditors

	2022 £m	2021 £m
<b>Amounts falling due within one year:</b>		
Bank loans and overdrafts	8.4	1.9
Amounts owed to subsidiary undertakings	24.1	12.0
Other payables	1.3	0.1
Accruals	1.5	1.0
	<b>35.3</b>	<b>15.0</b>

Amounts owed to subsidiary undertakings bore interest at a nil rate and are repayable on demand.

## 8. Other financial liabilities

Other financial liabilities of £nil at 31 March 2022 (2021: £9.3m) comprise drawdowns on the Group's revolving credit facility (see note 23 to the consolidated Financial Statements). The 2021 amount was denominated in Sterling and bore interest based on SONIA.



### 9. Called up share capital

	2022 Number	2022 £m	2021 Number	2021 £m
<b>Allotted, called up and fully paid</b>				
Ordinary shares of 5p each	<b>95,456,109</b>	<b>4.7</b>	89,455,915	4.4

During the year to March 2022, 650,000 shares were issued to the Group's Employee Benefit Trust (2021: 750,000).

On 2 September 2021, 5,350,194 shares were issued for a gross consideration of £55m before costs and £53.5m after costs. The shares were issued at 1,028 pence per share, which is equal to the mid-market closing price of 1,028 pence per share on 2 September 2021. £0.3m was share capital with the balance of £53.2m being allocated to share premium account.

At 31 March 2022, there were outstanding options for employees of subsidiaries to purchase up to 2,985,201 (2021: 3,928,273) ordinary shares of 5p each between 2020 and 2031 at prices ranging from £nil per share to £8.03 per share. These are subject to certain performance conditions as disclosed in note 31 of the consolidated Financial Statements. During the year to 31 March 2022, employees exercised 1,170,882 share options under the terms of the various schemes (2021: 60,693). The shares exercised during the year ended 31 March 2022 were settled by the Trust.

### 10. Related parties

The Company is exempt under the terms of FRS 101 from disclosing related party transactions with wholly-owned entities that are part of the Group as these transactions are fully eliminated on consolidation.

### 11. Financial guarantees

The Company has issued corporate guarantees to banks for bank borrowings of its subsidiaries. These guarantees are financial guarantees as they require the Company to reimburse the banks if the subsidiaries fail to make principal or interest payments when due in accordance with the terms of their borrowings. Borrowings by subsidiaries undertakings totalling £65.5m which are included in the Group's borrowings (note 23) have been guaranteed by the company.

### 12. Share-based payments

For detailed disclosures of share-based payments granted to the employees of subsidiaries refer to note 31 of the consolidated Financial Statements.

### 13. Post balance sheet events

There were no matters arising, between the statement of financial position date and the date on which these financial statements were approved by the Board of Directors, requiring adjustment in accordance with IAS 10. Events after the reporting period. The following important non-adjusting events should be noted:

#### Dividends

A final dividend of 7.45p per share (2021: 7.0p), amounting to a dividend of £7.1m (2021: £6.2m) and bringing the total dividend for the year to 10.8p (2021: 10.15p), was declared by the Board on 14 June 2022.

#### Revolving Credit Facility

On 3 May 2022, the Group increased its syndicated banking facility from £180m to £240m and extended the remaining term of the facility by two years out to four years ending in June 2026, with an option exercisable by the Group to extend the facility by a further year to June 2027. In addition, the Group has an £80m accordion facility which it can use to extend the total facility up to £320m.



## Other Information

### FIVE YEAR RECORD

	2022 £m	2021 restated* £m	2020 restated* £m	2019 restated* £m	2018 restated* £m
<b>Group Statement of Profit or Loss – continuing operations</b>					
Revenue	<b>379.2</b>	302.8	303.3	268.2	224.4
Underlying operating profit	<b>41.4</b>	30.8	30.8	22.5	17.0
Underlying profit before tax	<b>37.6</b>	27.2	26.5	19.0	14.4
Profit before tax	<b>17.1</b>	13.5	13.2	11.2	7.3
Profit for the year from continuing operations	<b>9.7</b>	9.5	9.3	8.6	5.1
<b>Earnings per share – continuing operations</b>					
Underlying earnings per share	<b>29.4p</b>	22.4p	24.4p	19.0p	14.6p
Diluted earnings per share	<b>10.1p</b>	10.3p	10.6p	11.3p	6.9p
Dividend per share	<b>10.8p</b>	10.15p	2.97p	9.55p	9.0p
<b>Group statement of financial position</b>					
Net debt	<b>(30.2)</b>	(47.2)	(61.3)	(63.3)	(52.4)
Non-current assets	<b>326.5</b>	244.6	236.4	149.2	136.4
Net assets	<b>290.4</b>	208.4	200.5	134.7	126.8

The figures for 2020 onwards included the impact of the adoption of IFRS 16.

\*The Group has restated the prior year comparatives in the consolidated Statement of Profit or Loss to exclude the results of discontinued operations with the objective of ensuring that the amounts disclosed for the year ended 31 March 2022 are comparable with the results for the year ended 31 March 2021 and earlier years (the comparative periods). Details of the financial position and results for the discontinued operations can be found in note 12 to the consolidated Financial Statements.



## PRINCIPAL LOCATIONS

### Group head office

Location	Company	City
United Kingdom	discoverIE Group plc	Guildford
	discoverIE Management Services Limited	Guildford

### Operating companies

Location	Company	City
United Kingdom	Antenova Limited	Hatfield
	Contour Electronics Limited	Hook
	Cursor Controls Ltd	Newark
	Herga Technology Limited	Bury St. Edmunds
	Noratel UK Limited	Nantwich
	Sens-Tech Limited	Egham
	Stortech Electronics Limited	Harlow
	Variohm-Eurosensor Limited	Towcester, Cheltenham, Horsham
	Vertec Scientific Limited	Reading
Belgium	NSI BVBA	Bilzen
Canada	Noratel Canada Inc	Ontario
China Mainland	Foshan Noratel Electric Co Limited	Foshan City
	Zhongshan Myrra Electronic Co Limited	Zhongshan
Denmark	Noratel Denmark A/S	Glostrup
	Flux A/S	Asnaes
Finland	Noratel Finland OY	Salo
France	Myrra SAS	Bussy-Saint-Georges
Germany	Limitor GmbH	Urbach
	Limitor Solutions GmbH	Urbach
	MTC Micro Tech Components GmbH	Dillingen
	Noratel Germany AG	Grafenau, Bremen
	Santon GmbH	Nettetal
	Variohm-Eurosensor	Heidelberg
Hong Kong	Contour Asia Limited	Kowloon
	Myrra Hong Kong Limited	Wanchai
Hungary	Limitor Hungaria Elektromechanikai Gyarto Kft.	Pecs
India	Noratel India Power Components Pvt Limited	Kerala, Bangalore
Mexico	Hobart Electronics	Agualeguas, Nogales
Netherlands	Santon Holland BV	Rotterdam
Norway	Foss AS	Drammen
	Noratel AS	Hokksund, Hamar
Poland	Myrra Poland sp. z o.o.	Kaluszyn
	Noratel sp. z o.o.	Szczecinska
Slovakia	Foss Fibre Optics s.r.o.	Bratislava
South Korea	EMC Innovation Limited	Cheongcheon-Dong
Sri Lanka	Noratel International Pvt Limited	Katunayake
Sweden	Hectronic AB	Uppsala
	Noratel Sweden AB	Laxa, Vaxjo
Taiwan	Antenova Asia	Taipei
Thailand	Flux International Limited	Bangkok
USA	Calculagraph Company	East Hanover, NJ
	Hobart Electronics	Hobart, IN
	IMAG Electronics	Tempe, AZ
	Logic PD, Inc.	Eden Prairie, MN
	Noratel North America LLC	Charlotte, NC
	Noratel Power Engineering LLC	Long Beach, CA
	Phoenix America LLC	Fort Wayne, IN



Other Information

## FINANCIAL CALENDAR 2022/23

### Annual General Meeting

28 July 2022

### Results

Interim results for the six months to 30 September 2022

Late November 2022

Preliminary announcement for the year to 31 March 2023

Early June 2023

Annual Report 2023

Late June 2023

## CORPORATE INFORMATION

### Registered office

discoverIE Group plc

2 Chancellor Court

Occam Road

Surrey Research Park

Guildford

Surrey GU2 7AH

Telephone: 01483 544500

Incorporated in England and Wales  
with registered number: 02008246

### Corporate solicitors

White & Case LLP

### Principal bankers

Bank of Ireland

Clydesdale Bank plc

Citibank NA Inc

Danske Bank A/S

Fifth Third Commercial Bank

HSBC Bank UK plc

KBC Bank NV

### Registrar

Equiniti Limited

Aspect House

Spencer Road

Lancing

West Sussex BN99 6DA

Telephone: 0371 384 2001

### Stockbroker

Peel Hunt LLP

### Auditors

PricewaterhouseCoopers LLP





discoverIE

discoverIE Group plc

2 Chance of Court  
Oxham Road, Surrey Research Park  
Culford, Surrey  
GU27 7AH

Telephone +44 (0)1483 544500

Fax +44 (0)1483 544550

[www.discoverIEplc.com](http://www.discoverIEplc.com)